



# SPECIFICATION FOR TFT LCD MODULE

CUSTOMER : \_\_\_\_\_

CUSTOMER MODULE : \_\_\_\_\_

HL MODEL : \_\_\_\_\_ HG028HS003 \_\_\_\_\_



## ■ Final Specification

Customer Confirmation column:

\_\_\_\_\_ Dept. : \_\_\_\_\_ Data : \_\_\_\_\_

Please return one of the copies of the specification with your signature to us within two weeks after you receive this document. If it is not returned, we will assume that you agree to the entire contents of this specification document.

Designed by	Checked by	Approved by





## CONTENTS 目录

1. General Specifications 基本规格
2. Pin Assignments 接口定义描述
3. Electrical Specification 电气特性
  - 3.1 Absolute Maximum Ratings 极限参数
  - 3.2 Typical Operation Conditions 典型工作条件
  - 3.3 Backlight Circuit Characteristics 背光电气特性
  - 3.4 LCD Current Consumption 液晶面板功耗
4. Optical Specification 光学规格
  - 4.1 LCM Optical Characteristics 液晶模组光学特性
  - 4.2 Measurement system 测量系统
5. Mechanical Drawing 模组图
6. Reliability Test Items 可靠性测试项目
7. Packing and Storage Specification (Reference only)  
包装规格 (仅供参考)
8. Announcements 注意事项



## 1. General Specifications 基本规格

No.	Item 项目	Specification 规格	Unit 单位	Remark
1	LCD Size 液晶面板尺寸	2.76"	inch	-
2	Panel Type 面板类型	IPS	-	-
3	Resolution 分辨率	480xRGBx480	Pixel	-
4	Display Mode 显示模式	Normally Black	-	-
5	Number of Colors 颜色数量	262K	-	-
6	Viewing Direction 使用视角	ALL	-	Note1
7	NTSC 色彩饱和度	65%	-	Typ.
8	Contrast Ratio 对比度	1200	-	
9	Luminance 亮度	300	cd/m2	Typ.
10	Module Size 模组尺寸	73.33(H)x76.82(V)x2.2(D)	mm	Note1
11	Panel Active Area 可视区域	70.13x70.13	mm	Note1
12	Pixel Pitch 像素尺寸	0.1461x0.1461	mm	-
13	Pixel Arrangement 像素排列	RGB-stripe		-
14	Weight 重量	TBD	g	-
15	Driver IC 驱动芯片	ST7701S	-	-
16	Driver IC RAM Size 记忆体	RAM less	bit	-
17	Light Source 背光源	4 LED light	-	-
18	Interface 接口方式	3SPI+RGB 18BIT	-	-
19	Operating Temperature 工作温度	-20~+70	°C	-
20	Storage Temperature 存储温度	-30~+80	°C	-



## 2. Pin Assignments 接口定义

Pin No. Pin 序号	Symbol 符号	Function 功能描述
1	LEDA	Backlight anode
2-3	LEDK	Backlight cathode
4	GND	Ground
5	VCI	Power Supply for LCM
6	RESET	Reset Signal
7-8	NC	No connection
9	SDA	Serial data signal in serial I/F
10	SCK	Serial clock signal in serial I/F
11	CS	Chip selected in serial I/F
12	PCLK	Pixel clock signal in RGB I/F
13	DE	Data enable signal in RGB I/F DE mode
14	VSYNC	Vertical sync . Signal in RGB I/F
15	HSYNC	Horizontal sync . Signal in RGB I/F
16-33	DB0~DB17	Data bus in RGB I/F
34	GND	Ground
35	TP-EINT	CTP interrupt signal
36	TP-SDA	CTP I2C data pin
37	TP-SCL	CTP I2C clock pin
38	TP-RST	CTP reset pin
39	TP-VCI	Power Supply for CTP
40	GND	Ground



## 3. +Electrical Specification 电气特性

### 3.1 Absolute Maximum Ratings 极限参数

Item 项目	Symbol	Value	Unit	Remark
Analog Power Supply Voltage 模拟供电电压	VDD	-0.3~+3.3	V	-
Logic Input Voltage Range	VIN	-0.3~VDDI+0.3	V	-
Logic Output Voltage Range	VO	-0.3~VDDI+0.3	V	-

### 3.2 Typical Operation Conditions 典型工作条件

Item 项目	Symbol	Min.最小	Typ.典型	Max.最大	Unit
Supply Voltage 供电电压	VDD	2.5	2.8	3.3	V
Input High Voltage 输入高电平	V <sub>IH</sub>	0.7*VDD	-	VDD	V
Input Low Voltage 输入低电平	V <sub>IL</sub>	DGND	-	0.3*VDD	V
Output High Voltage 输出高电平	V <sub>OH</sub>	VDD-0.4	-	VDD	V
Output Low Voltage 输出低电平	V <sub>OL</sub>	DGND	-	DGND+0.4	V



### 3.3 Backlight Circuit Characteristics 背光功耗

Item	Symbol	Min.	Typ.	Max.	Unit
LED Current 背光电流	I <sub>B</sub>	-	80	-	mA
LED Voltage 背光电压	V <sub>f</sub>	-	3	-	V
Power Consumption 功耗	P <sub>BL</sub>	-	640	-	mW

### 3.4 LCD Current Consumption 液晶面板功耗

Item	Symbol	Typ.	Max.	Unit
Full Mode 正常模式	V <sub>CI</sub>	-	-	mW
测试条件：V <sub>CI</sub> =2.8V，IOVCC=2.8V； Interface 驱动类型：行翻转或者列翻转； TN Type=>All Black Pattern. TN型液晶面板=>黑色画面； IPS Type=>All White Pattern. IPS型液晶面板=>白色画面； Temperature：25°C；温度：室温25摄氏度；				
Sleep Mode 休眠模式	V <sub>CI</sub>	-	-	mW
测试条件：V <sub>CI</sub> =2.8V，IOVCC=2.8V； DC/DC converter is enabled. Internal oscillator is started and panel scanning is started. 除IC内部晶振和面板扫描外，其他功能都暂停工作； Temperature：25°C；温度：室温25摄氏度；				



## 4. Optical Specification 光学参数

### 4.1 LCM Optical Characteristics 液晶模组光学特性

Item		Symbol	Condition	Min.	Typ.	Max.	Unit
Viewing Angle Range 视角	Left	$\theta_L$	$CR \geq 10$	80	85	-	degree
	Right	$\theta_R$		80	85	-	
	Top	$\theta_T$		80	85	-	
	Bottom	$\theta_B$		80	85	-	
Response Time 响应时间		$T_{on}+T_{off}$	$\theta=\Phi=0^\circ$	-	35	40	ms
Contrast Ratio 对比度		CR	$\theta=\Phi=0^\circ$	1000	1200	-	-
Luminance 亮度		L	$\theta=\Phi=0^\circ$		300	-	cd/m <sup>2</sup>
Color Chromaticity (CIE1931) 色坐标	White	$W_x$	Normal $\theta=\Phi=0^\circ$		0.298		-
		$W_y$			0.327		
	Red	$R_x$			0.647		
		$R_y$			0.313		
	Green	$G_x$			0.263		
		$G_y$			0.560		
	Blue	$B_x$			0.137		
		$B_y$			0.106		
Uniformity 均匀度		$U_L$	$\theta=\Phi=0^\circ$	-	80	-	%
Flicker 闪烁		-	-	No Visible			-





## 4.2 Measurement system 测量系统

### 4.2.1 LCM Viewing Angle

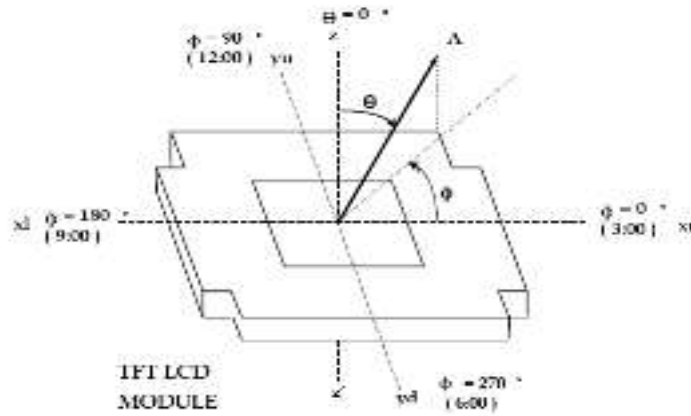

Viewing angle is the angle at which the contrast ratio is greater than 10. The angles are determined for the horizontal or x axis and the vertical or y axis with respect to the z axis which is normal to the LCD surface.



## 4.2.2 Response time

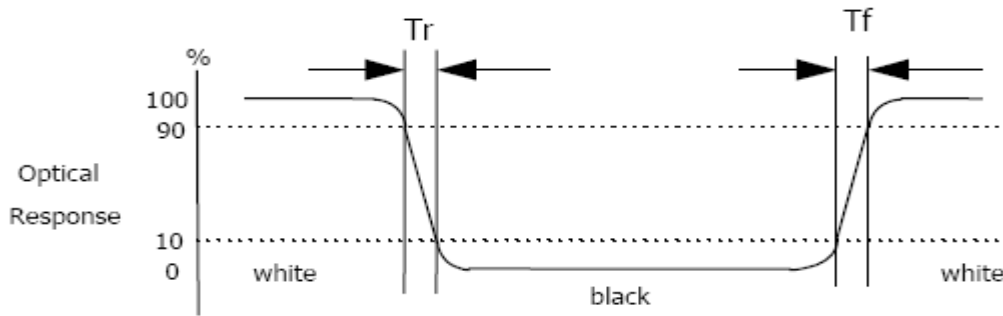

Response time is the time required for the display to transition from white to black (Rising time,  $T_r$ ) and from black to white (Falling time,  $T_f$ ) for additional information.

## 4.2.3 Contrast Ratio (CR)

Contrast Ratio (CR) is defined mathematically as:

$$\text{Contrast Ratio} = \frac{\text{Surface Luminance with all white pixels}}{\text{Surface Luminance with all black pixels}}$$

Surface luminance is the center point across the LCD surface 500mm from the surface with all pixels displaying white.



## 5. Mechanical Drawing 模组图

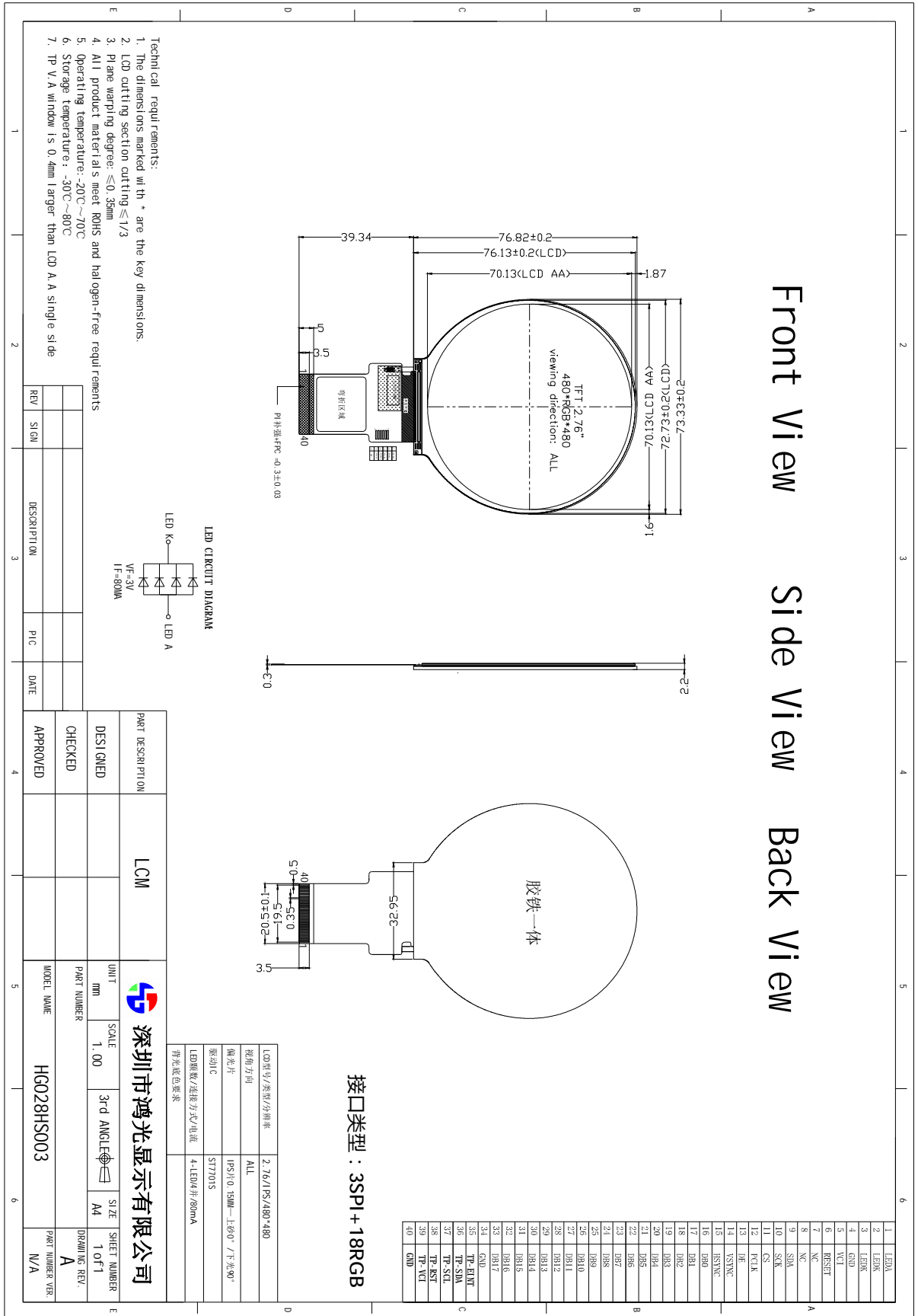



## 6. Reliability Test Items 可靠性测试项目

Test Item 测试项目	Test Condition 测试条件	Test result determinant gist 实验结果判定
High temperature storage 高温存储	80±3°C , 24H ;	Inspection after 2~4hours storage at room temperature, the sample shall be free from defects: 试验结束后,已测试的LCD样品必须在室内正常温湿度环境下放置2~4个小时以上才能进行功能和外观检查, 样品不允许有以下缺陷: 1.Air bubble in the LCD; 模块中有气泡; 2.Non-display; 不显示; 3.Glass crack; 玻璃破碎; 4. The electrical characteristics requirements shall be satisfied. 需要满足模块电气性能。
Low temperature storage 低温存储	-30±3°C , 24H ;	
High temperature operation 高温运行测试	70±3°C , 24H ;	
Low temperature operation 低温运行测试	-20±3°C , 24H ;	
High temperature /humidity 高温高湿	60°C±3°C,90%±3%RH , 24H ;	
Thermal Shock 冷热冲击	-30°C/0.5h~+80°C/0.5h for a total 24 cycles ;	
Vibration Test 振动测试	Frequency 10Hz~55Hz~10Hz Amplitude : 1.5mm, X , Y , Z direction for total 1H ; (Packing condition)	
ESD test 静电测试	±2KV, Human Body Mode, 150pF/330Ω ; ±8KV, Air Mode, 150pF/330Ω ;	

Remark: 注意:

1. The test samples should be applied to only one test item.

每个被测试的模块只能用于其中的一个测试项目。

2. Sample size for each test item is 2pcs.

每个测试项目的样品数量为2片。



3. Failure Judgment Criterion: Basic Specification, Electrical Characteristic, Mechanical Characteristic,

Optical Characteristic.

故障判断标准:基本规格,电气特性,机械特性,光电特性。



## 7. Packing and Storage Specification(Reference Only) **包装存储**

### 7.1 Packing Method **包装方法**

TBD

### 7.2 Storage Method **存储方法**

1.Store in an ambient temperature of  $23^{\circ}\text{C}\pm 5^{\circ}\text{C}$ , and in a relative humidity of  $55\%\pm 15\%$ . Don't exceed 12 months and expose to sunlight or fluorescent light.

存储环境温度为  $23\pm 5^{\circ}\text{C}$ ，相对湿度为  $55\%\pm 15\%$ ，存储不能超过 12 个月，不要长时间暴晒。

2. Store in a clean environment, free from dust, active gas, and solvent.

存储在一个干净的环境，不受灰尘，活性气体和溶剂污染。

3. Store in antistatic container.

存储在防静电环境。

## 8. Announcements **注意事项**

1.Do not attempt to disassemble or process the LCD module.

请勿拆卸液晶显示模块。

2.Do not make extra holes on the printed circuit board, modify its shape or change the positions of components to be attached.

不要在印制电路板上钻额外的孔，修改形状或更改印制线路板上元件的位置。

3.Except for soldering the interface, do not make any alterations or modifications with a soldering iron; Ensure welding temperature at  $320^{\circ}\text{C}$  to  $350^{\circ}\text{C}$ , the welding time



control within the 10 s, welding note don't stay too long in the same place to avoid scald FPC.

除焊接接口外，不要用烙铁做任何更改；焊接温度保证在 320°C-350°C，焊接时间控制在 10S 以内，焊接时注意不要在同一处停留时间太久以免烫伤 FPC。

4. Other matters in not clear before use, please contact our staff to guide.

其他事项在不清楚使用之前，请联系我司人员指导进行。

-END-