



# SPECIFICATION FOR TFT LCD MODULE

CUSTOMER : \_\_\_\_\_

CUSTOMER MODULE : \_\_\_\_\_

HL MODEL :           HG047HD002T01          

Preliminary Specification

Final Specification

Customer Confirmation column:

Approved by : \_\_\_\_\_ Dept. : \_\_\_\_\_ Data : \_\_\_\_\_

Please return one of the copies of the specification with your signature to us within two weeks after you receive this document. If it is not returned, we will assume that you agree to the entire contents of this specification document.

Designed by	Checked by	Approved by



## Revision History

Version NO.	DATE	Description	Remak
V1.0	2019.08.08	FIRST ISSUE	



## CONTENTS

No.	ITEM	PAGE
1.	GENERAL INFORMATION	4
2.	DIAGRAM FOR LCM	5
3.	I/O CONNECTION & BLOCK DIAGRAM	6~7
4.	ABSOLUTE MAXIMUM RATINGS	8
5.	ELECTRICAL CHARACTERISTICS	9~11
6.	ELECTRO-OPTICAL CHARACTERISTICS	12~14
7.	RELIABILITY TEST CONDITIONS	15
8.	INSPECTION STANDARDS	16~18
9.	PACKAGE DRAWING	18



## 1. GENERAL INFORMATION

### 1.1 features

- 1) Structure: TFT PANNEL+IC+FPC+BL
- 2) IPS Type LCD 720 dot-segment and 1280 dot-common outputs
- 3) 16.7M Color can be selected by software
- 4) White LED back light
- 5) MIPI-4 interface
- 6) Operation Temperature : -20~70°C
- 7) Storage Temperature : -30~80°C
- 8) CTP cover lens : Asahi
- 9) CTP structure : G+F+F
- 10) LED life time: -/

### 1.2 General specification

Item of	Contents	Unit
Panel Size	4.7	inch
LCD Type	a-si/TRANSMISSIVE	/
Display mode	Normally Black	/
Pixel arrangement	720*3(RGB)*1280	Dots
Pixel pitch (W*H)	0.0807 (H)*0.0807 (V)	um
Active Area	58.1 (H)*103.3 (V)	Mm
Module area (W*H*T)	64.8H)*113.15(V)*3.15(T)	Mm
Recommended Viewing Direction	ALL	0' clock
LCM IC	JD9365A	/
TP IC	GT917S	
Interface	MIPI-4	/
Luminance for LCM+TP	300	cd/m2
Weight	TBD	g





## 3. I/O CONNECTION & BLOCK DIAGRAM

### 3.1 I/O connection

LCM Pin NO.	Symbol	I/O	Description
1	LEDA	P	Power supply for LED anode
2	NC	-	NC
3	LEDK	P	Power supply for LED cathode
4	NC	-	NC
5	TE		TE
6	RESET	I	The signal will reset the LCM, Signal is active low.
7	VDD-1.8	P	A power supply for the logic power and I/O circuit(1.8V)
8	VDD-2.8	P	A power supply for the logic power and I/O circuit(2.8V)
9	NC	-	NC
10	GND	P	Power Ground
11	TDP0	I	DSI-D0+ differential data signals for MIPI interface
12	TDN0	I	DSI-D0- differential data signals for MIPI interface
13	GND	P	Power Ground
14	TDP1	I	DSI-D1+ differential data signals for MIPI interface
15	TDN1	I	DSI-D1- differential data signals for MIPI interface
16	GND	P	Power Ground
17	TCP	I	DSI-CLK+ differential clock signals for MIPI interface
18	TCN	I	DSI-CLK- differential clock signals for MIPI interface
19	GND	P	Power Ground
20	TDP2	I	DSI-D2+ differential data signals for MIPI interface
21	TDN2	I	DSI-D2- differential data signals for MIPI interface
22	GND	P	Power Ground
23	TDP3	I	DSI-D3+ differential data signals for MIPI interface
24	TDN3	I	DSI-D3- differential data signals for MIPI interface
25	GND	P	Power Ground

I: Input; O: Output; P: Power

TP Pin NO.	Symbol	I/O	Description
1	SDA	I/O	I2C data signals for TP
2	SCL	I	I2C clock signals for TP
3	RST	I	The signal will reset the TP, Signal is active low.
4	INT	O	Interrupt signals for TP
5	AVDD	P	TP-VCC(3.3V) Power Supply for TP
6	GND	P	Power Ground



## 3.2 block diagram

MCU and Display Module Interface Configuration

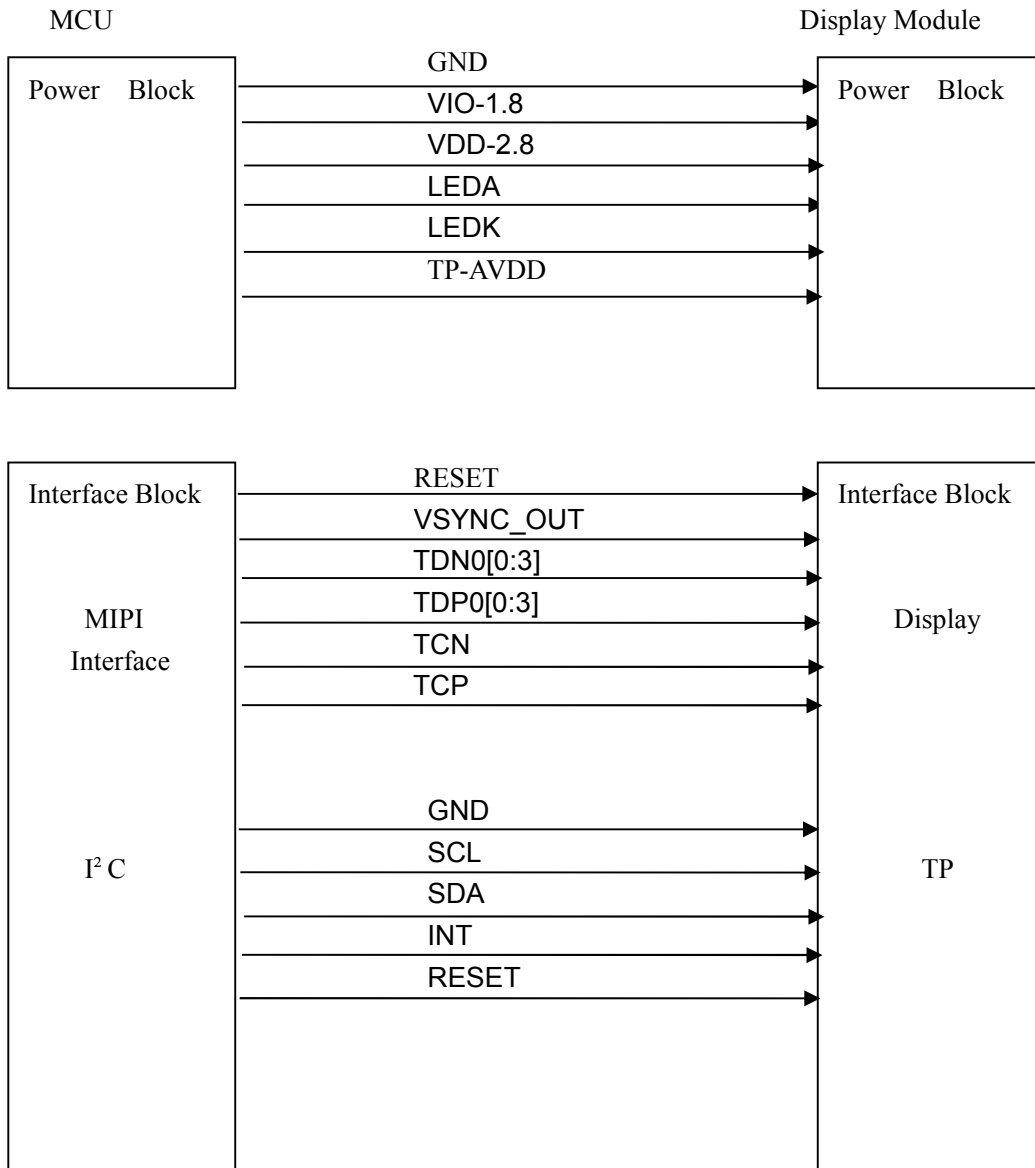



## 4. ABSOLUTE MAXIMUM RATINGS

(GND=AGND=0V)

Item	Symbol	Values			Unit	Remarks
		Min.	Typ.	Max.		
Power Voltage Supply1	VDD-2.8	2.5	3.3	6.6	V	
Power Voltage Supply2	VIO-1.8	1.65	1.8	3.6	V	
Luminance(LCM+TP)	L <sub>v</sub>	-	300	-	cd/m <sup>2</sup>	
Backlight Forward Voltage	V <sub>f</sub>	-	16	-	V	
LED Forward Current	I <sub>f</sub>	-	40	-	MA	Note

## 5. ELECTRICAL CHARACTERISTICS

### 5.1 LED backlight specification :

项目	符号	额定值	单位
工作电流	I <sub>BL</sub>	20*2	mA
工作电压	V <sub>BL</sub>	3.2*5	V
亮度	Lum	TBD	CD/M <sup>2</sup> (*)
X 色坐标	0.26	0.29	0.32
Y 色坐标	0.27	0.30	0.33

Note: The "LED life time" is defined as the module brightness decrease to 50% of original brightness at I<sub>L</sub>=20Ma(for each led). The LED life time could be decreased if operating I<sub>L</sub> is larger than 20mA

Note: 10 chips (5 series 2 parallel) connection, LED luminous color: WHITE.





## 5.2 DC characteristics

Item	Symbol	Condition	Min.	Typ.	Max.	Unit	Note
<b>Power &amp; Operation Voltage</b>							
Analog operating voltage	VCI	-	2.5	2.8	6.6	V	
Analog operating voltage	VCIREF	-	2.5	2.8	6.6	V	
Digital operating voltage	VDDI	-	1.65	2.8	3.6	V	
Digital operating voltage	VCC1	-	1.65	2.8	6.6	V	
Digital operating voltage	VCC2	-	1.65	2.8	6.6	V	
DSI operating voltage	VDDAM	-	1.65	1.8	3.6	V	
OTP Supply voltage	MTP_PWR	-	8.4	8.5	8.6	V	
Analog operating voltage	VSP	-	4.5	-	6.6	V	
Analog operating voltage	VSN	-	-6.6	-	-4.5	V	
Logic High level input voltage	VIH	-	0.7*VDDI	-	VDDI	V	Note1
Logic Low level input voltage	VIL	-	-0.3	-	0.3*VDDI	V	Note1
Logic High level output voltage TE, LEDPWM	VOH	IOH = -1.0mA	0.8*VDDI	-	VDDI	V	Note1
Logic Low level output voltage TE, LEDPWM	VOL	IOL = +1.0mA	0	-	0.2*VDDI	V	Note1
Gate Driver High Voltage	VGH	-	8.0	-	18	V	
Gate Driver Low Voltage	VGL	-	-18.0	-	-7.0	V	
Driver Supply Voltage	-	VGH-VGL	15	-	32	V	
<b>VCOM Operation</b>							
DC VCOM Amplitude Voltage	VCOM	-	-4.0	-	0	V	Note3
<b>Source Driver</b>							
Source Output Range	VSOUT(+)	-	0.3	-	VREG1OUT-0.1	V	Note4
	VSOUT(-)	-	VREG2OUT +0.1	-	-0.3	V	Note4
Positive Gamma Reference Voltage	VREG1OUT	-	3.5	-	VSP-0.5 (VSP<=6.1) 5.6 (VSP>6.1)	V	
Negative Gamma Reference Voltage	VREG2OUT	-	VSN+0.5 (VSN>=-6.1) -5.6 (VSN<-6.1)	-	-3.5	V	
Source Output Settling Time	Tr	Below with 99% precision	-	10	-	μs	Note3.4
Output Deviation Voltage (Source Output channel)	Vdev	Sout>=4.2V	-	-	20	mV	Note3
		Sout<=0.8V	-	-	15	mV	
Output Offset Voltage	VOFFSET	-	-	-	35	mV	Note3
<b>Standby mode current consumption</b>							
Sleep In mode	I(VDDI SLP IN)	Ta = 25 °C VCI=2.8V	-	35	-	μA	
	I(VCI SLP IN)	VDDI=1.8V	-	25	-	μA	

### Notes:

1. Ta = -30 to 70 °C (to 85 °C no damage), VCI = 2.5V to 6.6V, VDDI = 1.65V to 3.6V
2. Supply digital VDDI voltage equal or less than analog VCI voltage.
3. Source channel loading = 9KΩ, 70pF/channel
4. The maximum value is between with Note 3 and Gamma setting value



## 5.3 AC Characteristics

### 5.31 High Speed Mode – Data Clock Channel Timing

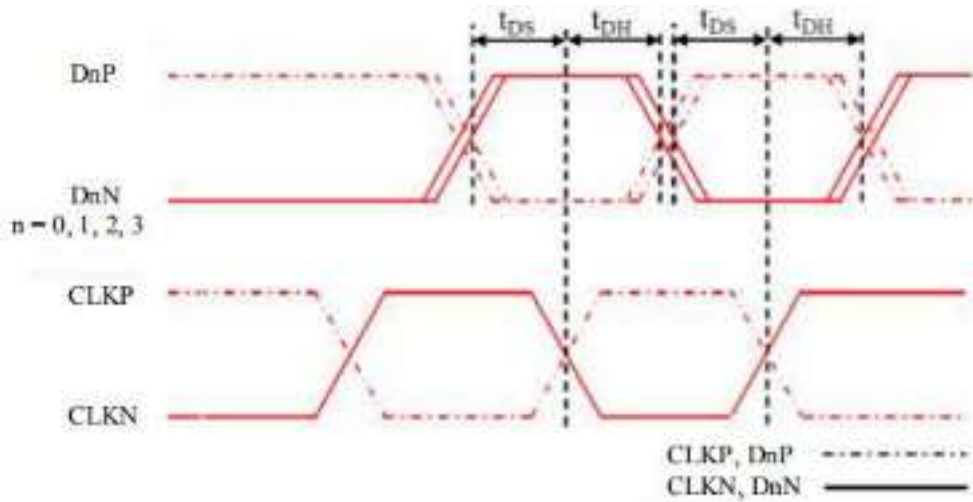

DSI Data to Clock Channel Timings

Signal	Symbol	Parameter	Min	Max
DnP/N, n=0 and 1	$t_{DS}$	Data to Clock Setup time	$0.15 \times UI$	-
	$t_{DH}$	Clock to Data Hold Time	$0.15 \times UI$	-

### 5.32 High Speed Mode – Rising and Falling Timings

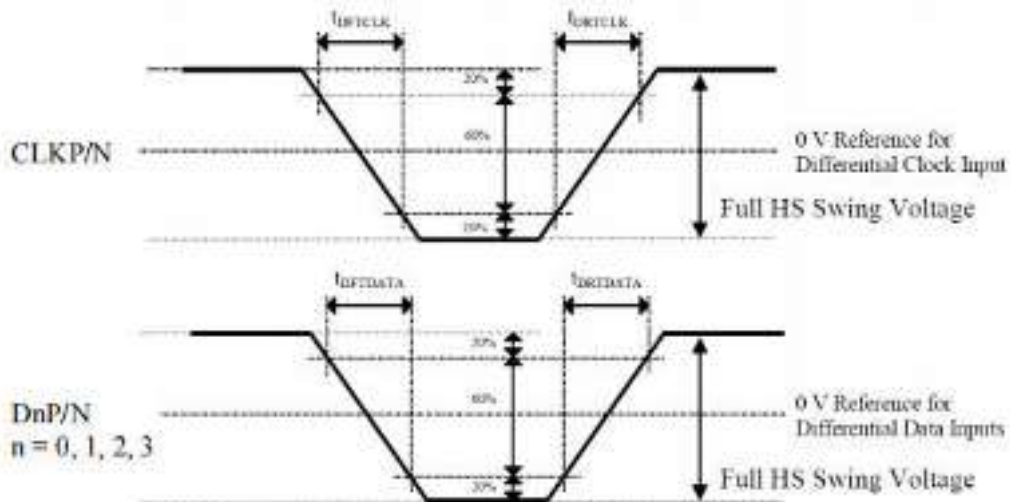

Rise and Fall Timings on Clock and Data Channels

Parameter	Symbol	Condition	Specification		
			Min	Typ	Max
Differential Rise Time for Clock	$t_{RfCLK}$	CLKP/N	150 ps	-	$0.3UI$ (Note)
Differential Rise Time for Data	$t_{RfDATA}$	DnP/N n=0 and 1	150 ps	-	$0.3UI$ (Note)
Differential Fall Time for Clock	$t_{FfCLK}$	CLKP/N	150 ps	-	$0.3UI$ (Note)
Differential Fall Time for Data	$t_{FfDATA}$	DnP/N n=0 and 1	150 ps	-	$0.3UI$ (Note)



## 5.33 Reset Timing

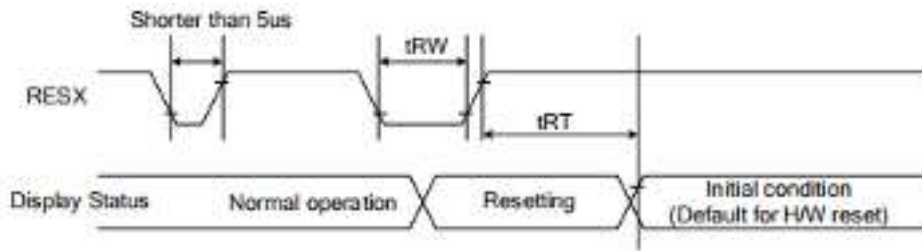

## 5.34 Power Structure

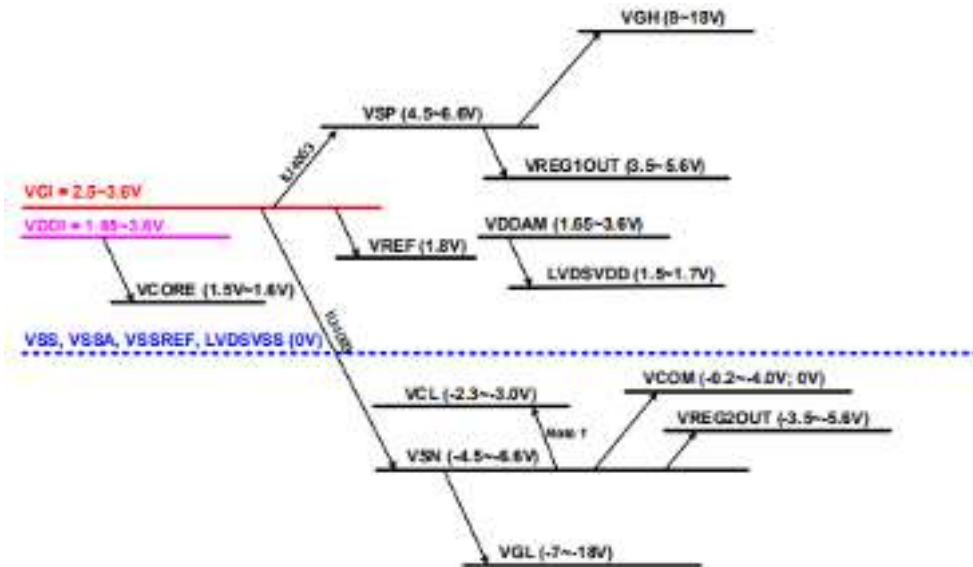

## 5.4 Power Mode

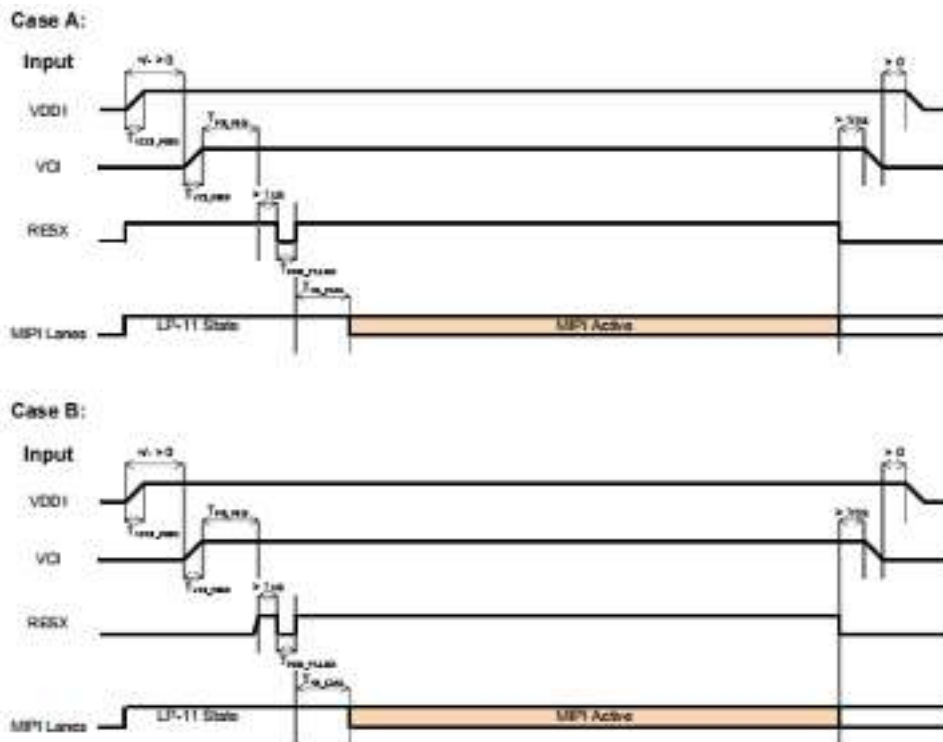



## 6. ELECTRO-OPTICAL CHARACTERISTICS

Item	Symbol	Condition	Min.	Typ.	Max.	Unit	Note	
Brightness	Bp	$\Phi_1=0^\circ$	-	300	-	Cd/m <sup>2</sup>	1	
Uniformity	$\Delta Bp$	$\Phi_2=0^\circ$	80%				1,2	
Viewing Angle	$\Phi_1$ (up down)	$Cr \geq 10$	80typ			Deg	3	
	$\Phi_2$ (left right)		80typ					
Contrast Ratio	Cr	$\Theta=0$ Normal	-	1500	-	-	4	
Response Time	Tr+Tf	Viewing angle	-	25	30	ms	5	
Color of CIE Coordinate	W	x	-	0.295	-	-	1,6	
		y	-	0.323	-	-		
	R	x	-	0.660	-	-		
		y	-	0.323	-	-		
	G	x	$\Phi_1=0^\circ$ $\Phi_2=0^\circ$	-	0.258	-		-
		y	-	0.590	-	-		
	B	x	-	0.137	-	-		
		y	-	0.089	-	-		



Note1 Definition of Contrast Ratio (CR):

$$\text{Contrast ratio (CR)} = \frac{\text{Luminance measured when LCD on the "White" state}}{\text{Luminance measured when LCD on the "Black" state}}$$

Note2: Definition of Luminance Uniformity: Active area is divided into 9 measuring areas (Shown in below), every measuring point is placed at the center of each measuring area.

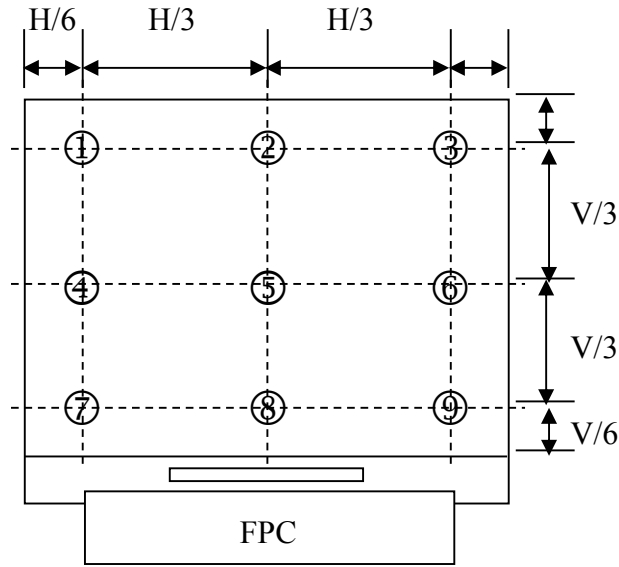

The spot locations for luminance measurement

$$\text{Luminance Uniformity} = \frac{H/6 B_{\min}}{V/6 B_{\max}} \times 100\%$$

$B_{\max}$ : The measured maximum luminance of all measurement position.

$B_{\min}$ : The measured minimum luminance of all measurement position.

Note 3: Definition of Response time: Sum of  $T_r$  and  $T_f$

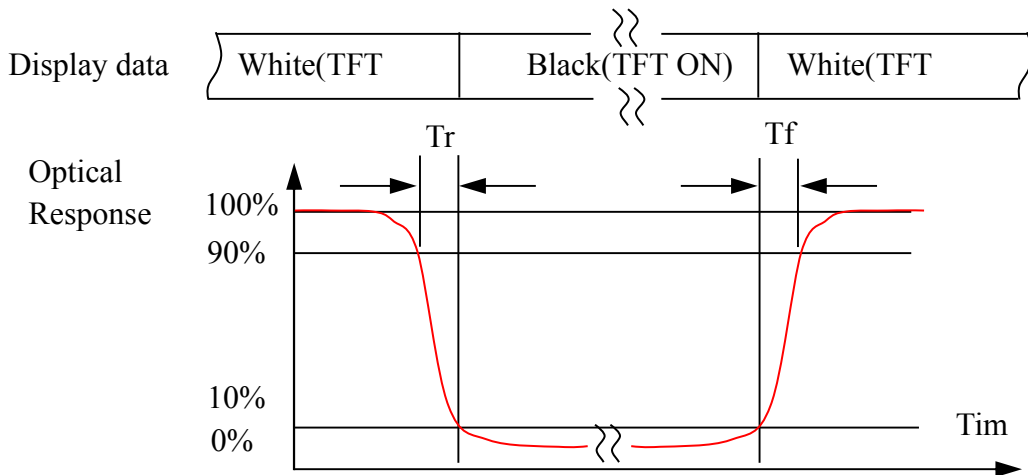



Note4. Definition of Viewing Angle: The viewing angle range that the  $CR \geq 10$

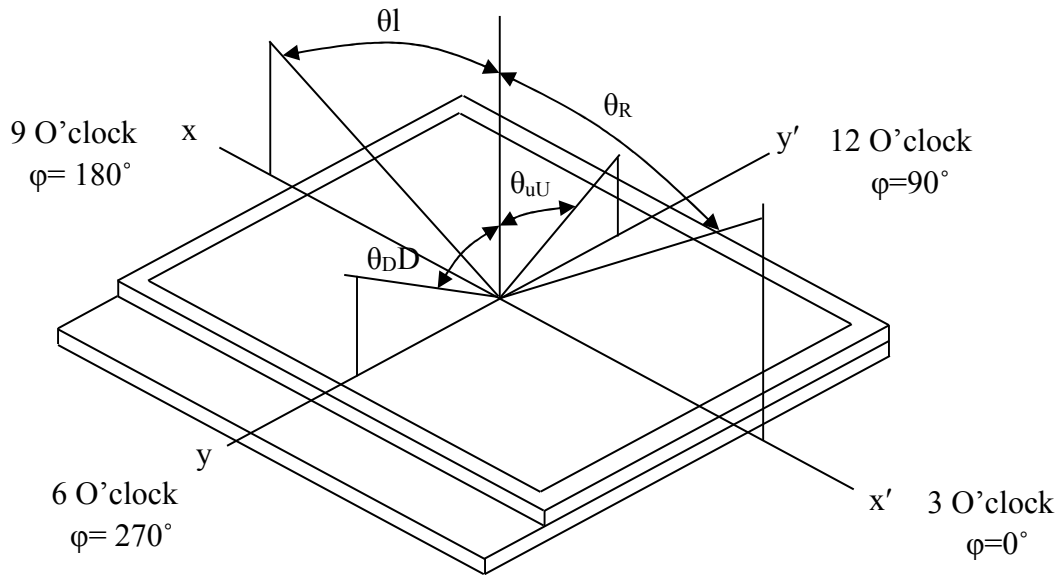

Note 5: Definition of Color Chromaticity (CIE 1931)

Color coordinate of white & red, green, blue at center point.



## 7. RELIABILITY TEST CONDITIONS

No	Test Item	Test Condition	STANDARD
1	High Temperature Storage	+80°C / 96Hours	1. Functional test is OK. Missing Segment, short, unclear segment, on-display, display abnormally and liquid crystal leak are un-allowed. 2. No low temperature bubbles, end seal loose and fall, frame rainbow.
2	Low Temperature Storage	-30°C / 96Hours	
3	High Temperature Operating	+70°C / 96Hours	
4	Low Temperature Operating	-20°C / 96Hours	
5	Thermal and cold shock	0°C↔+50°C x 10cycles (30min) (5min) (30min)	
6	Operate at High Temperature and Humidity	60°C x 90%RH / 24H	
7	Vibration Test	Frequency: 10Hz~55Hz~10Hz Amplitude:1.5mm, 2 hours for each direction of X, Y, Z	1. Function test is OK. 2. No glass crack, chipped glass, end seal loose and fall, epoxy frame crack and so on. 3. No structure loose and fall.
8	Dropping test	Drop to the ground from 1m height, 1 corner, 3 edges, 6 surfaces.	
9	ESD test	Contact: ±6KV Air: ±10KV 150PF/330Ω,5Points/panel,5times	
			The test results shall be subject to the whole machine test.

### NOTE:

1. The reliability items will be fully performed in new sample qualification,
2. The reliability status will be tested as monitor during mass production. Individual reliability test shall be performed by lot, Moreover, the individual reliability item shall be decided according to reliability plan.
3. All samples are inspected after keeping in the room with normal temperature and humidity for 2 hours or above.
4. Vibration test: It is not necessary to test for those products without assembly frame, backlight, PCB and so on.
5. Dropping test: It is necessary for affirming new package.
6. For the high temperature and high humidity test, pure water of over 10 MΩ.cm should be used.
7. Each test item applies for test LCM only once. Then tested LCM cannot be used again in any other test item.
8. The quantity of LCM examination for each test item is 5pcs to 10pcs.



## 8. INSPECTION STANDARDS

### 8.1 AQL Sampling inspection standard

使用 GB/T 2828-2003 一般 II 水平, 采用正常检查一次抽样方式; 具体抽检方式参照《成品检验管理程序》、《抽样管理规范》

缺陷区分	AQL 允收水准
严重缺陷	0 收 1 退
重缺	0.4
轻缺	1.0

### 8.2 Inspect the condition

8.2.1 在 20—40W 日光灯的照明条件下, 样品离检查者眼睛约 30cm 处进行检查。检验方向以垂直线前后左右 45° (以时钟 3 点、6 点、9 点、12 点)

8.2.2 检验者视力需达到标准视力 1.0 以上。

8.2.3 检验者需戴静电手环、两手八个手指套。

8.2.4 外观检验者以目视检查或以菲林对比卡比对。

8.2.5 电性测试使用电测测架, 主板, 电源线及单片机。

8.2.6 若标准与规格书不符时, 以产品发行之规格书特殊检验规格、工程变更为准

8.2.7 辉色度检测请参照样品, 检测方法依照辉色度检验标准。

8.2.8 电测检验环境: 照度为 200LUX 以下, 外观检验环境: 照度为 600LUX-1000LUX, 检验时间: 1 秒-3 秒。

8.2.9 检验工具: 电测测架, 主板, 电源线及单片机, 菲林对比卡, 游标卡尺, 放大镜, 实体显微镜 (必要时) 等等。

### 8.3 Judgment criterion

小尺寸点、线判定标准: (6.2 寸以内)

1	点状缺陷 (磨伤、异物、针孔、凹痕、缺膜、气泡、白点、彩点、脏点)		判定 (A/B/C 区)	$D \leq 0.10$ , 忽略不计, 但密集型不允许	MI	OK
				$0.1 < D \leq 0.15$ , $ds \geq 10$		$N \leq 2$
				$0.15 < D \leq 0.2$ , $ds \geq 10$		$N \leq 1$
				LCD 亮点: $0.15 < D$		$N \leq 1$
				$D > 0.2$		NG
			判定 (D 区)	同背面丝印油墨区杂质判定标准		
			注: 1) D 区的点状缺陷需在不影响 CTP 功能、客户组装及整机的外观的情况下, 判定 OK		MI	
2	线状缺陷 (磨伤、无感划伤、毛屑、纤维等)		判定 (A/B/C 区)	$W \leq 0.03mm$ , $L \leq 3mm$ , $ds \geq 10$	MI	$N \leq 2$
				$0.03mm < W \leq 0.05mm$ , $L \leq 3mm$ , $ds \geq 10$		$N \leq 1$
				$W > 0.05mm$ 或 $L > 3mm$		NG





## 中尺寸点、线判定标准：（6.2~8寸以内）

1	点状缺陷 (磨伤、异物、针孔、凹痕、缺膜、气泡、白点、彩点、脏点)		判定(A/B/C区)	$D \leq 0.10$ , 忽略不计, 但密集型不允许	MI	OK
				$0.15 < D \leq 0.25$ , $ds \geq 10$		$N \leq 2$
				$0.25 < D \leq 3$ , $ds \geq 10$		$N \leq 1$
				LCD 亮点: $0.2 < D$		$N \leq 1$
				$D > 0.3$		NG
判定(D区)	同背面丝印油墨区杂质判定标准					
注: 1) D区的点状缺陷需在不影响CTP功能、客户组装及整机的外观的情况下, 判定OK					MI	
2	线状缺陷 (磨伤、无感划伤、毛屑、纤维等)		判定(A/B/C区)	$W \leq 0.03mm$ , $L \leq 3mm$ , $ds \geq 10$	MI	$N \leq 2$
				$0.03mm < W \leq 0.05mm$ , $L \leq 3mm$ , $ds \geq 10$		$N \leq 1$
				$W > 0.05mm$ 或 $L > 3mm$		NG

## 大尺寸点、线判定标准：（8.1~13.3寸以内）

1	点状缺陷 (磨伤、异物、针孔、凹痕、缺膜、气泡、白点、彩点、脏点)		判定(A/B/C区)	$D \leq 0.1$ , 忽略不计, 但密集型不允许	MI	OK
				$0.15 < D \leq 0.3$ , $ds \geq 10$		$N \leq 2$
				$0.3 < D \leq 0.35$ , $ds \geq 10$		$N \leq 1$
				LCD 亮点: $0.25 < D$		$N \leq 1$
				$D > 0.35$		NG
判定(D区)	同背面丝印油墨区杂质判定标准					
注: 1) D区的点状缺陷需在不影响CTP功能、客户组装及整机的外观的情况下, 判定OK					MI	
2	线状缺陷 (磨伤、无感划伤、毛屑、纤维等)		判定(A/B/C区)	$W \leq 0.05mm$ , $L \leq 5mm$ , $ds \geq 10$	MI	$N \leq 2$
				$0.05mm < W \leq 0.07mm$ , $L \leq 5mm$ , $ds \geq 10$		$N \leq 1$
				$W > 0.07mm$ 或 $L > 5mm$		NG



## 9. PACKAGE DRAWING

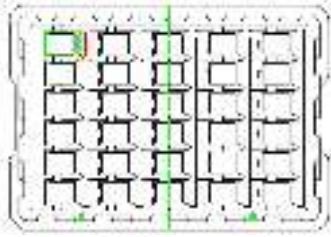

一盘:TBD pcs

9.2

Use empty tray



Put products into the tray



一叠:TBD pcs 盘

9.3

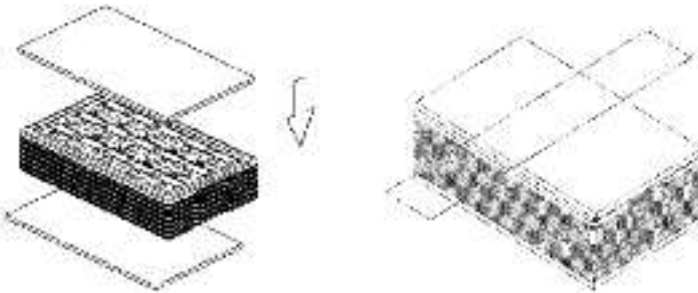

9.4

