



SPECIFICATION FOR TFT LCD MODULE

CUSTOMER : _____

CUSTOMER MODULE : _____

HL MODEL : _____ HG062WV003 _____

Preliminary Specification

Final Specification

Customer Confirmation column:

Approved by : _____ Dept. : _____ Data : _____

Please return one of the copies of the specification with your signature to us within two weeks after you receive this document. If it is not returned, we will assume that you agree to the entire contents of this specification document.

Designed by	Checked by	Approved by



CONTENTS

No.	ITEM	PAGE
1.	GENERAL INFORMATION	4
2.	DIAGRAM FOR LCM	5
3.	I/O CONNECTION & BLOCK DIAGRAM	6~7
4.	ABSOLUTE MAXIMUM RATINGS	8
5.	ELECTRICAL CHARACTERISTICS	9~12
6.	ELECTRO-OPTICAL CHARACTERISTICS	13~15
7.	RELIABILITY TEST CONDITIONS	16
8.	INSPECTION STANDARDS	17~18
9.	PACKAGE DRAWING	19



1. GENERAL INFORMATION

1.1 features

- 1) Structure: TFT PANNEL+IC+FPC+BL
- 2) IPS Type LCD 800 dot-segment and 480 dot-common outputs
- 3) 16.7M Color can be selected by software
- 4) White LED back light
- 5) RGB-24 interface
- 6) Operation Temperature : -20~70℃
- 7) Storage Temperature : -30~80℃
- 8) CTP cover lens : - /
- 9) CTP structure : - /
- 10) LED life time: -/

1.2 General specification

Item of	Contents	Unit
Panel Size	6.2	inch
LCD Type	a-si/TRANSMISSIVE	/
Display mode	Normally WHITE	/
Pixel arrangement	800*3 (RGB)*480	Dots
Pixel pitch (W*H)	0.1719 (H)*0.1609 (V)	um
Active Area	137.52 (H)*77.232 (V)	Mm
Module area (W*H*T)	155.2 (H)*88.2 (V)*5 (T)	Mm
Recommended Viewing Direction	6	0' clock
Interface	RGB-24	/
Luminance for LCM+TP	500	cd/m2
Weight	TBD	g



2. DIAGRAM FOR LCM

由 Autodesk 教育版产品制作

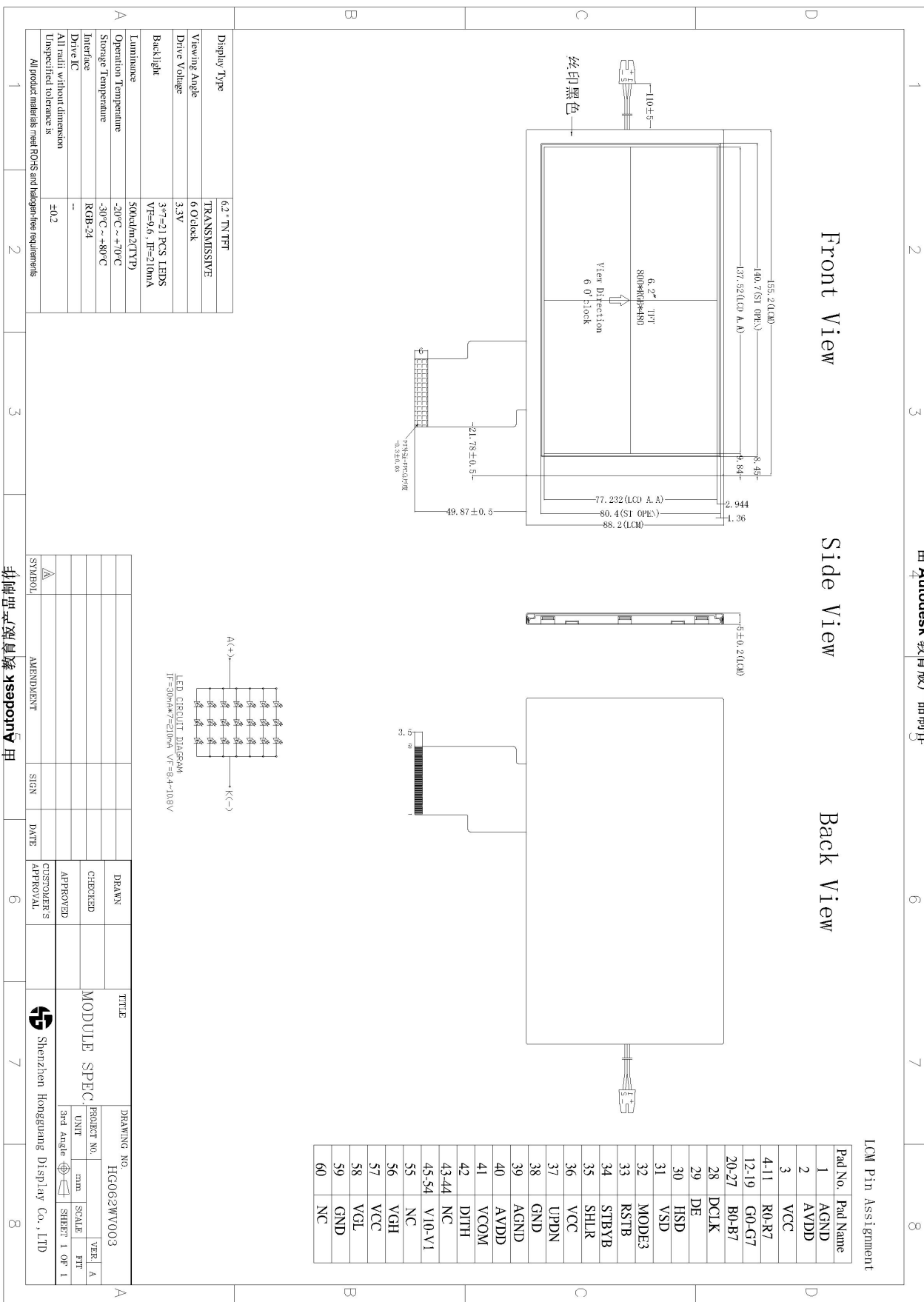

由 Autodesk 教育版产品制作



3. I/O CONNECTION & BLOCK DIAGRAM

3.1 I/O connection

Pin NO.	Symbol	I/O	Description
1	AGND	P	Analog Ground
2	AVDD	P	Analog Power
3	VCC	P	Digital Power
4-11	R0-R7	I	Data Input
12-19	G0-G7	I	Data Input
20-27	B0-B7	I	Data Input
28	DCLK	I	Clock input
29	DE	I	Data Enable signal
30	HSD	I	Horizontal sync input.Negative polarity
31	VSD	I	Vertical sync input.Negative polarity
32	MODE3	I	DE/SYNC mode select .normally pull high H:DE mode.L:HSD/VSD mode
33	RSTB	I	global reset pin.Active low to enter reset state.suggest to connecting with an RC reset circuit for stability .normally pull high.
34	STBYB	I	standby mode,normally pull high STBYB="1",normal operation STBYB="0",timming control ,sorce driver will turn off,all output are high-Z
35	SHLR	I	Source right or left sequence control.SHLR="L",shift left:last data=S1<-S2...S1200=first data SHLR="H",shift right:first data=S1->SS2...S1200=last data
36	VCC	P	Digital Power
37	UPDN	I	gate up or down scan control. UPDN="L" , DOWN shift:G1->G2...->G480 ; UPDN="H", up shift: G1<-G2...<-G480
38	GND	P	Digital Ground
39	AGND	P	Analog Ground
40	AVDD	P	Analog Power
41	VCOMin	I	For external VCOM DC input(Optional)
42	DITH	I	Dithering setting: DITH="H" 6bit resolution (last 2bits of input data truncated) (default setting) DITH="L" 8bit resolution
43	NC	-	NC
44	NC	-	NC
45	V10	P	Gamma correction voltage reference
46	V9	P	Gamma correction voltage reference
47	V8	P	Gamma correction voltage reference
48	V7	P	Gamma correction voltage reference
49	V6	P	Gamma correction voltage reference
50	V5	P	Gamma correction voltage reference



51	V4	P	Gamma correction voltage reference
52	V3	P	Gamma correction voltage reference
53	V2	P	Gamma correction voltage reference
54	V1	P	Gamma correction voltage reference
55	NC	-	NC
56	VGH	P	Positive Power for TFT
57	VCC	P	Digital Power
58	VGL	P	Negative Power for TFT
59	GND	P	Digital Ground
60	NC	-	NC

I: Input; O: Output; P: Power



4. ABSOLUTE MAXIMUM RATINGS

(GND=AGND=0V)

Item	Symbol	Values		Unit	Remarks
		Min.	Max.		
Power Voltage Supply	VCC	-0.3	6	V	
	VGH	-0.3	40	V	
	VGL	-20	0.3		
	AVDD	-0.5	15	V	
	VCOM	0	6		
Logic Signal Input Level	V	-0.3	VCC+0.3	V	

Back-Light Unit

Item	Symbol	Min.	Typ.	Max.	Unit	Note
LED current	I_{BL}	-	210	-	mA	(1) (2) (3)
LED voltage	V_{BL}	-	9.6	-	V	(1) (2) (3)
Operating LED life time	Hr	20,000	-	-	Hour	

Note

(1) Permanent damage may occur to the LCD module if beyond this specification. Functional operation should be restricted to the conditions described under normal operating conditions.

(2) $T_a = 25 \pm 2$

(3) Test Condition: LED current 210 mA. The LED lifetime could be decreased if operating IL is larger than 210 mA.

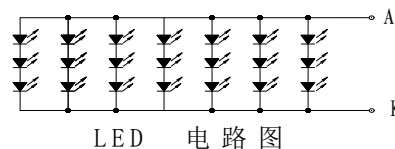



5. ELECTRICAL CHARACTERISTICS

5.1 DC characteristics

Item	Symbol	Min.	Typ.	Max.	Unit	Note
Supply Voltage	V _{CC}	TBD	3.3	TBD	V	
	V _{GH}	TBD	15	TBD	V	
	V _{GL}	TBD	-7	TBD	V	
	AV _{DD}	TBD	10	TBD	V	
VCOM	VCOMin	-	TBD	-	V	
Input signal voltage	V _H	0.7 V _{CC}	-	V _{CC}	V	Note (1)
	V _L	0	-	0.3 V _{CC}	V	
Current of power supply	I _{DD}	-	TBD	-	mA	V _{CC} = 3.3V
	I _{AOD}	-	TBD	-	mA	AV _{DD} = 10 V (Black)
	I _{GH}	-	TBD	-	mA	V _{GH} = 15V
	I _{GL}	-	TBD	-	mA	V _{GL} = -7V
Input level of V1~V5	V _X	AV _{DD} /2-		AV _{DD} -0.1-	V	
Input level of V6~V10	V _X	0.1-		AV _{DD} /2-	V	

Note (1): HSYNC, VSYNC, DE, Digital Data

Note (2): Be sure to apply the power voltage as the power sequence spec.

Note (3): DGND=AGND=0V.)



5.2 AC Characteristics

Item	Symbol	Min.	Typ.	Max.	Unit	Note
DCLK cycle time	Tcph	25			ns	
DCLK frequency	fcik		30	40	MHz	
DCLK pulse duty	Tcwh	40	50	60	%	
VSD setup time	Tvst	8			ns	
VSD hold time	Tvhd	8			ns	
HSD setup time	Thst	8			ns	
HSD hold time	Thhd	8			ns	
Data setup time	Tdsu	8			ns	
Data hold time	Tdhd	8			ns	
DE setup time	Tesu	8			ns	
DE hold time	Tehd	8			ns	
Horizontal display area	thd		800		Tcph	
HSD period time	th		928		Tcph	
HSD pulse width	thpw	1	48		Tcph	
HSD back porch	thb		40		Tcph	
HSD front porch	thfp		40		Tcph	
Vertical display area	tvd		480		th	
VSD period time	tv		525		th	
VSD pulse width	tvpw		3		th	
VSD back porch	tvb		29		th	
VSD front porch	tvfp		13		th	

5.3 Timing Diagram of Interface Signal

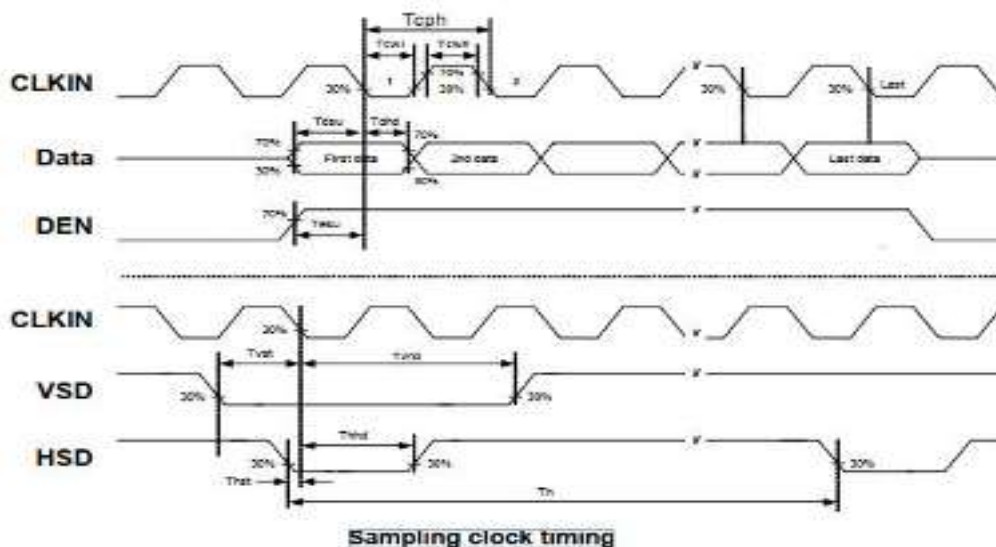

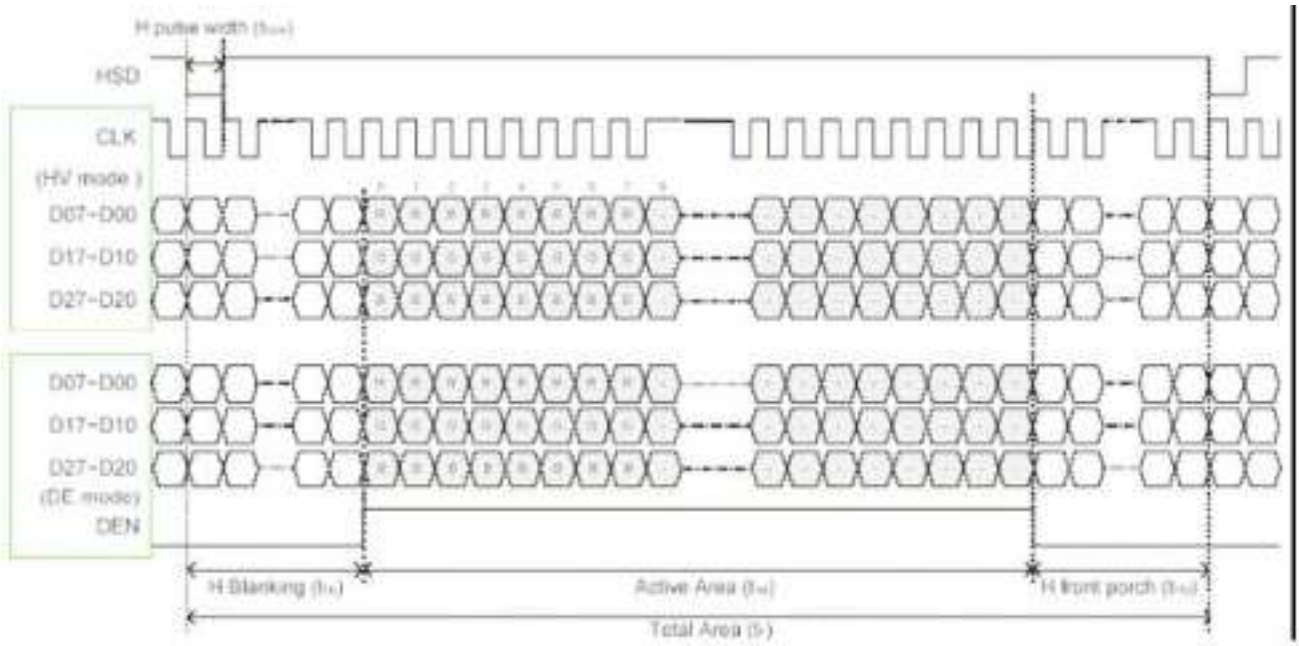

Horizontal display timing range

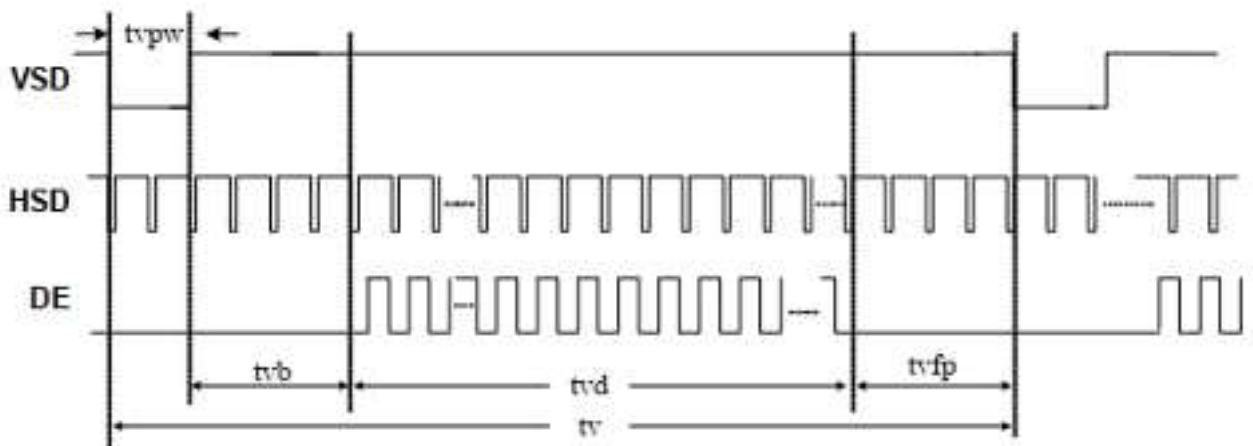

Vertical timing



5.4 Power Sequence

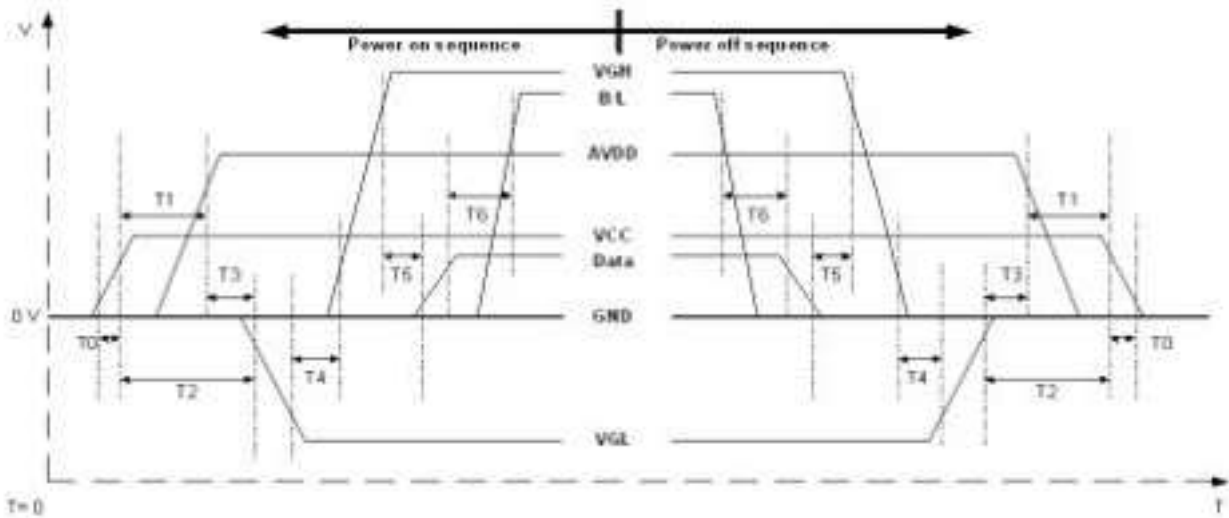

Item	Min.	Typ.	Max.	Unit
T0	0.5	--	20	msec
T1	16			msec
T2	20			msec
T3	0			msec
T4	20		--	msec
T5	20			msec
T6	50			msec

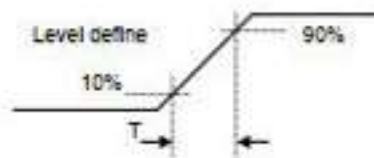

Power On Sequence: VCC-> AVDD -> VGL -> VGH -> Data -> B/L

Power Off Sequence: B/L-> Data -> VGH -> VGL -> AVDD -> VCC

Notes: Data include R0~R7, G0~G7, B0~B7, HSD, VSD, DCLK, SHLR, UPDN, DE MODE, RSTB, STBYB, SHLR, UPDN, DITH



6. ELECTRO-OPTICAL CHARACTERISTICS

Item	Symbol	Condition	Min.	Typ.	Max.	Unit	Note
Brightness	Bp	$\Phi_1=0^\circ$	400	500	-	Cd/m ²	1
Uniformity	ΔBp	$\Phi_2=0^\circ$	70%				1,2
Viewing Angle	Φ_1 (up down)	$Cr \geq 10$	70typ			Deg	3
	Φ_2 (left right)		75typ				
Contrast Ratio	Cr	$\Theta=0$	480	600	-	-	4
Response Time	Tr	Normal Viewing angle	-	2	4	ms	5
	Tf			6	12		
Color of CIE Coordinate	W	x	0.260	0.310	0.360	-	1,6
		y	0.280	0.330	0.380	-	
Optima View Direction			6 O'clock				



Note1 Definition of Contrast Ratio (CR):

$$\text{Contrast ratio (CR)} = \frac{\text{Luminance measured when LCD on the "White" state}}{\text{Luminance measured when LCD on the "Black" state}}$$

Note2: Definition of Luminance Uniformity: Active area is divided into 9 measuring areas (Shown in below), every measuring point is placed at the center of each measuring area.

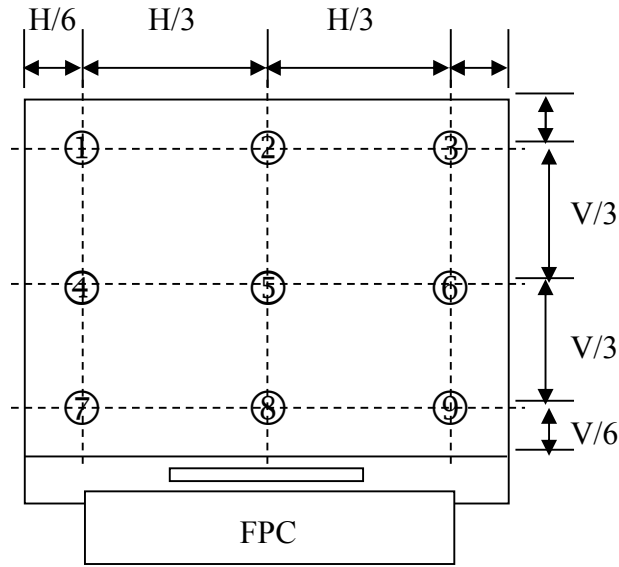

The spot locations for luminance measurement

$$\text{Luminance Uniformity} = \frac{H/6 B_{\min}}{V/6 B_{\max}} \times 100\%$$

B_{\max} : The measured maximum luminance of all measurement position.

B_{\min} : The measured minimum luminance of all measurement position.

Note 3: Definition of Response time: Sum of T_r and T_f

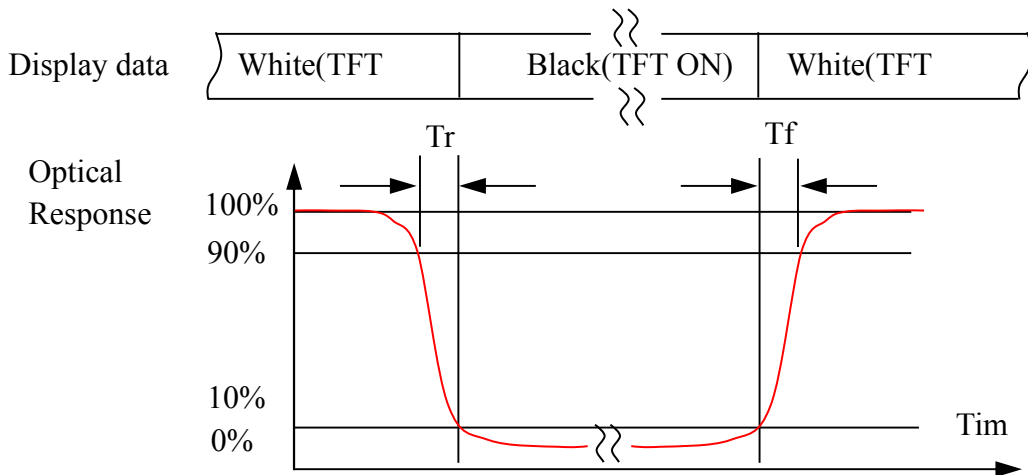



Note4. Definition of Viewing Angle: The viewing angle range that the $CR \geq 10$

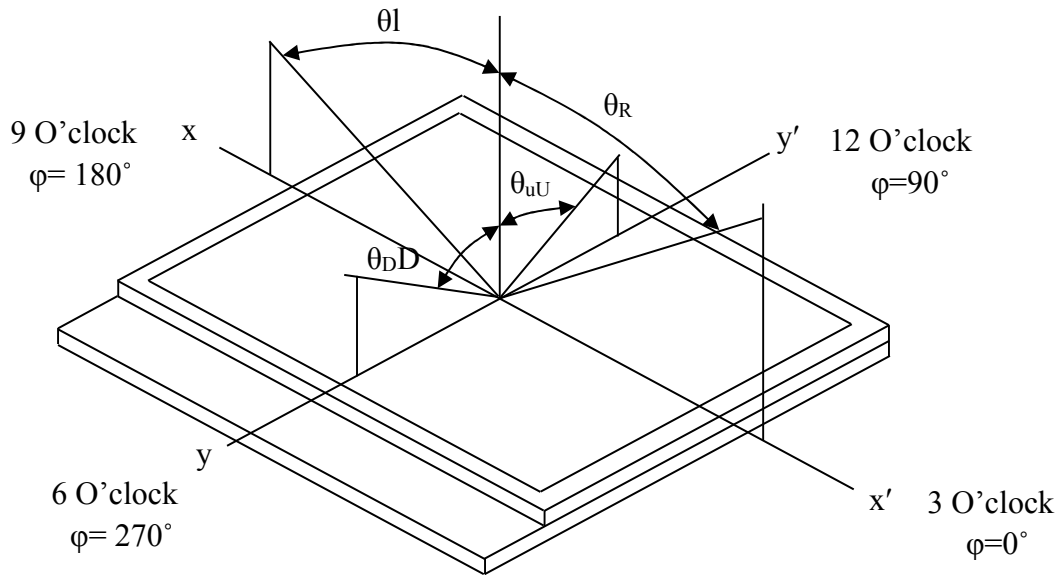

Note 5: Definition of Color Chromaticity (CIE 1931)

Color coordinate of white & red, green, blue at center point.



7. RELIABILITY TEST CONDITIONS

No	Test Item	Test Condition	STANDARD
1	High Temperature Storage	+80°C / 96Hours	1. Functional test is OK. Missing Segment, short, unclear segment, on-display, display abnormally and liquid crystal leak are un-allowed. 2. No low temperature bubbles, end seal loose and fall, frame rainbow.
2	Low Temperature Storage	-30°C / 96Hours	
3	High Temperature Operating	+70°C / 96Hours	
4	Low Temperature Operating	-20°C / 96Hours	
5	Thermal and cold shock	0°C↔+50°C x 10cycles (30min) (5min) (30min)	
6	Operate at High Temperature and Humidity	60°C x 90%RH / 24H	
7	Vibration Test	Frequency: 10Hz~55Hz~10Hz Amplitude:1.5mm, 2 hours for each direction of X, Y, Z	1. Function test is OK. 2. No glass crack, chipped glass, end seal loose and fall, epoxy frame crack and so on. 3. No structure loose and fall.
8	Dropping test	Drop to the ground from 1m height, 1 corner, 3 edges, 6 surfaces.	
9	ESD test	Contact: ±6KV Air: ±10KV 150PF/330Ω,5Points/panel,5times	

NOTE:

1. The reliability items will be fully performed in new sample qualification,
2. The reliability status will be tested as monitor during mass production. Individual reliability test shall be performed by lot, Moreover, the individual reliability item shall be decided according to reliability plan.
3. All samples are inspected after keeping in the room with normal temperature and humidity for 2 hours or above.
4. Vibration test: It is not necessary to test for those products without assembly frame, backlight, PCB and so on.
5. Dropping test: It is necessary for affirming new package.
6. For the high temperature and high humidity test, pure water of over 10 MΩ.cm should be used.
7. Each test item applies for test LCM only once. Then tested LCM cannot be used again in any other test item.
8. The quantity of LCM examination for each test item is 5pcs to 10pcs.



8. INSPECTION STANDARDS

8.1 AQL Sampling inspection standard

使用 GB/T 2828-2003 一般 II 水平, 采用正常检查一次抽样方式; 具体抽检方式参照《成品检验管理程序》、《抽样管理规范》

缺陷区分	AQL 允收水准
严重缺陷	0 收 1 退
重缺	0.4
轻缺	1.0

8.2 Inspect the condition

8.2.1 在 20—40W 日光灯的照明条件下, 样品离检查者眼睛约 30cm 处进行检查。检验方向以垂直线前后左右 45° (以时钟 3 点、6 点、9 点、12 点)

8.2.2 检验者视力需达到标准视力 1.0 以上。

8.2.3 检验者需戴静电手环、两手八个手指套。

8.2.4 外观检验者以目视检查或以菲林对比卡比对。

8.2.5 电性测试使用电测测架, 主板, 电源线及单片机。

8.2.6 若标准与规格书不符时, 以产品发行之规格书特殊检验规格、工程变更为准

8.2.7 辉色度检测请参照样品, 检测方法依照辉色度检验标准。

8.2.8 电测检验环境: 照度为 200LUX 以下, 外观检验环境: 照度为 600LUX-1000LUX, 检验时间: 1 秒-3 秒。

8.2.9 检验工具: 电测测架, 主板, 电源线及单片机, 菲林对比卡, 游标卡尺, 放大镜, 实体显微镜 (必要时) 等等。

8.3 Judgment criterion

小尺寸点、线判定标准: (6.2 寸以内)

1	点状缺陷 (磨伤、异物、针孔、凹痕、缺膜、气泡、白点、彩点、脏点)		判定 (A/B/C 区)	$D \leq 0.10$, 忽略不计, 但密集型不允许	MI	OK
				$0.1 < D \leq 0.15$, $ds \geq 10$		$N \leq 2$
				$0.15 < D \leq 0.2$, $ds \geq 10$		$N \leq 1$
				LCD 亮点: $0.15 < D$		$N \leq 1$
				$D > 0.2$		NG
			判定 (D 区)	同背面丝印油墨区杂质判定标准		
			注: 1) D 区的点状缺陷需在不影响 CTP 功能、客户组装及整机的外观的情况下, 判定 OK		MI	
2	线状缺陷 (磨伤、无感划伤、毛屑、纤维等)		判定 (A/B/C 区)	$W \leq 0.03mm$, $L \leq 3mm$, $ds \geq 10$	MI	$N \leq 2$
				$0.03mm < W \leq 0.05mm$, $L \leq 3mm$, $ds \geq 10$		$N \leq 1$
				$W > 0.05mm$ 或 $L > 3mm$		NG



中尺寸点、线判定标准：（6.2~8寸以内）

1	点状缺陷 (磨伤、异物、针孔、凹痕、缺膜、气泡、白点、彩点、脏点)		判定(A/B/C区)	$D \leq 0.10$, 忽略不计, 但密集型不允许	MI	OK
				$0.15 < D \leq 0.25, ds \geq 10$		$N \leq 2$
				$0.25 < D \leq 3, ds \geq 10$		$N \leq 1$
				LCD 亮点: $0.2 < D$		$N \leq 1$
				$D > 0.3$		NG
判定(D区)	同背面丝印油墨区杂质判定标准					
注: 1) D区的点状缺陷需在不影响CTP功能、客户组装及整机的外观的情况下, 判定OK					MI	
2	线状缺陷 (磨伤、无感划伤、毛屑、纤维等)		判定(A/B/C区)	$W \leq 0.03mm, L \leq 3mm, ds \geq 10$	MI	$N \leq 2$
				$0.03mm < W \leq 0.05mm, L \leq 3mm, ds \geq 10$		$N \leq 1$
				$W > 0.05mm$ 或 $L > 3mm$		NG

大尺寸点、线判定标准：（8.1~13.3寸以内）

1	点状缺陷 (磨伤、异物、针孔、凹痕、缺膜、气泡、白点、彩点、脏点)		判定(A/B/C区)	$D \leq 0.1$, 忽略不计, 但密集型不允许	MI	OK
				$0.15 < D \leq 0.3, ds \geq 10$		$N \leq 2$
				$0.3 < D \leq 0.35, ds \geq 10$		$N \leq 1$
				LCD 亮点: $0.25 < D$		$N \leq 1$
				$D > 0.35$		NG
判定(D区)	同背面丝印油墨区杂质判定标准					
注: 1) D区的点状缺陷需在不影响CTP功能、客户组装及整机的外观的情况下, 判定OK					MI	
2	线状缺陷 (磨伤、无感划伤、毛屑、纤维等)		判定(A/B/C区)	$W \leq 0.05mm, L \leq 5mm, ds \geq 10$	MI	$N \leq 2$
				$0.05mm < W \leq 0.07mm, L \leq 5mm, ds \geq 10$		$N \leq 1$
				$W > 0.07mm$ 或 $L > 5mm$		NG



9. PACKAGE DRAWING

LCM产品(刀卡类)包装流程图

1.0 包装材料清单:

见受控BOM

2.0 包装方法说明:

