



SPECIFICATION FOR TFT LCD MODULE

CUSTOMER : _____

CUSTOMER MODULE : _____

HL MODEL : HG070WS004P01

Preliminary Specification

Final Specification

Customer Confirmation column:

Approved by : _____ Dept. : _____ Data : _____

Please return one of the copies of the specification with your signature to us within two weeks after you receive this document. If it is not returned, we will assume that you agree to the entire contents of this specification document.

Designed by	Checked by	Approved by



CONTENTS

No.	ITEM	PAGE
1.	GENERAL INFORMATION	4
2.	DIAGRAM FOR LCM	5
3.	I/O CONNECTION	6~10
4.	PCB 参数	11~18
5.	RELIABILITY TEST CONDITIONS	19
6.	INSPECTION STANDARDS	20~21
7.	PACKAGE DRAWING	22



1. GENERAL INFORMATION

1.1 features

- 1) Structure: TFT PANNEL+IC+FPC+BL+PCBA
- 2) IPS Type LCD 1024 dot-segment and 600 dot-common outputs
- 3) 16.7M Color can be selected by software
- 4) White LED back light
- 5) LVDS interface
- 6) Operation Temperature : - 20~60°C
- 7) Storage Temperature : - 30~70°C
- 8) CTP cover lens : -/
- 9) CTP structure : -/
- 10) LED life time: -/

1.2 General specification

Item of	Contents	Unit
Panel Size	7.0	inch
LCD Type	a-si/TRANSMISSIVE	/
Display mode	Normally Black	/
Pixel arrangement	1024*3 (RGB) *600	Dots
Pixel pitch (W*H)	0.1506 (W) x0.1432 (H)	um
Active Area	154.2144 (H) x 85.92 (V)	Mm
Module area (W*H*T)	164.7 (W) ×99.96 (H) ×3.5 (T)	Mm
Recommended Viewing Direction	ALL	0' clock
IC	TBD	/
Interface	LVDS	/
Luminance for LCM	400	cd/m2
NTSC	50	%
Weight	TBD	g



2. DIAGRAM FOR LCM

由 Autodesk 教育版产品制作

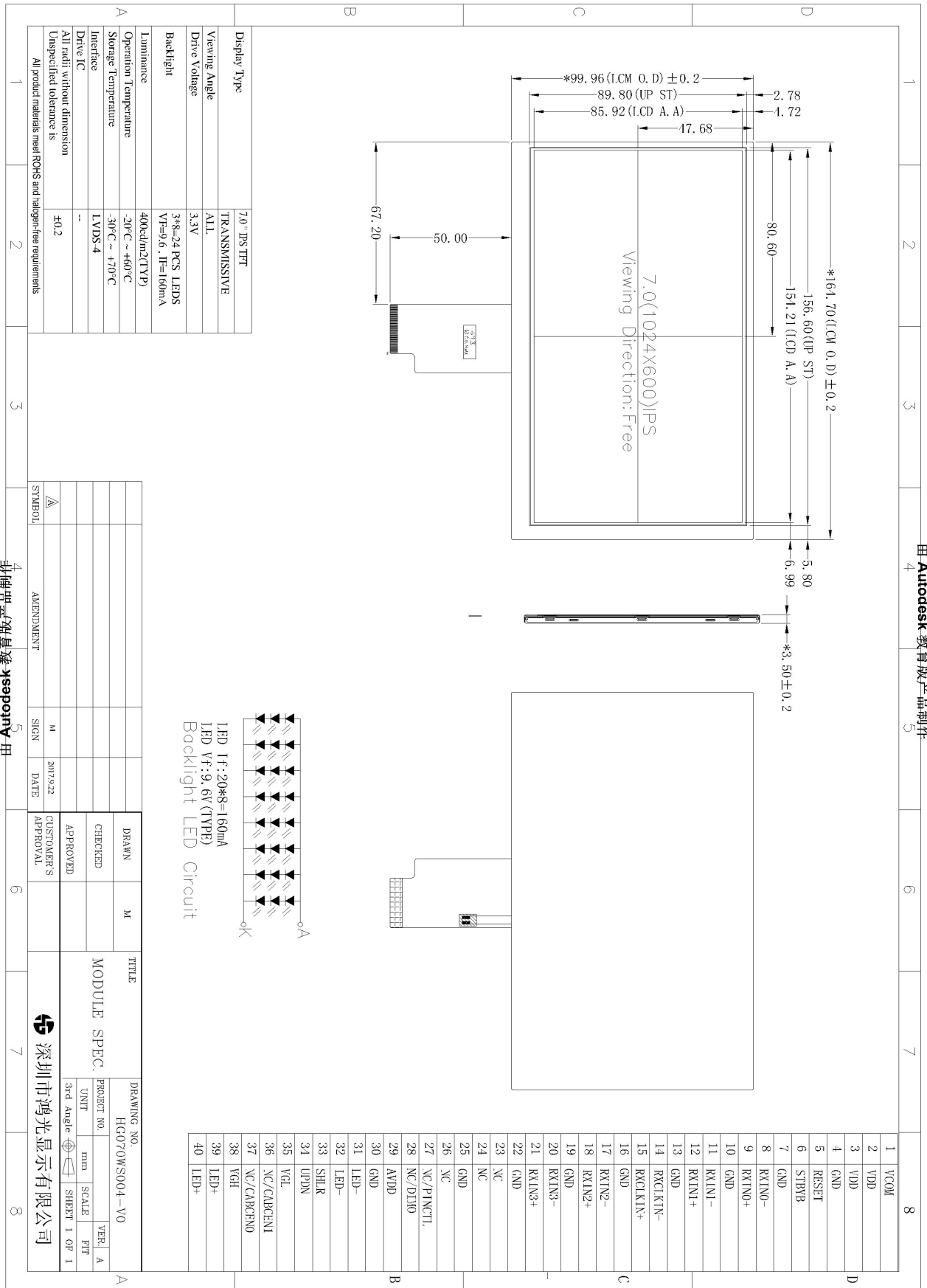

由 Autodesk 教育版产品制作

由 Autodesk 教育版产品制作



3. LCM main parameters

3.1 I/O CONNECTION

PIN NO.	SYMBOL	PIN NO.	SYMBOL
1	VCOM	31	LED-
2	VDD	32	LED-
3	VDD	33	SHLR
4	GND	34	UPDN
5	RESET	35	VGL
6	STBYB	36	NC/CABCEN1
7	GND	37	NC/CABCEN0
8	RXINO-	38	VGH
9	RXINO+	39	LED+
10	GND	40	LED+
11	RXIN1-		
12	RXIN1+		
13	GND		
14	RXCLKIN-		
15	RXCLKIN+		
16	GND		
17	RXIN2-		
18	RXIN2+		
19	GND		
20	RXIN3-		
21	RXIN3+		
22	GND		
23	NC		
24	NC		
25	GND		
26	NC		
27	NC/PINCTL		
28	NC/DIMO		
29	AVDD		
30	GND		

3.2 ABSOLUTE MAXIMUM RATINGS

Parameter	Symbol	Min	Max	Unit
Supply voltage for logic	V _{DD}	-0.3	3.0	V
Input voltage for logic	V _{IN}	-0.5	V _{DD} + 0.3	V
Supply current (One LED)	I _{LED}		20	mA
Operating temperature	T _{OP}			°C
Storage temperature	T _{ST}			°C



3.3 ELECTRICAL CHARACTERISTICS

Item	Symbol	Min	Typ	Max	Unit	Applicable terminal
Supply voltage for logic	V _{DD}	1.8	1.8	2	V	V _{DD}
Input voltage	V _{IL}	-0.3	-	0.2 V _{DD}	V	
	V _{IH}	0.8 V _{DD}	-	V _{DD}	V	
Input leakage current	I _{LKG}				μA	
AVDD current		9.2	9.6	10	V	
VGH current		17	21	19	V	
VGL current		-7	-7	-5	V	
VCOM current			3.6		V	
LED Forward voltage	V _f	8.6	9.6	10.1	V	-
Input backlight current	I _{LED}		160		mA	With One LED

3.4 DC CHARACTERISTICS

HV mode

Horizontal input timing

Parameter		Symbol	Value			Unit
Horizontal display area		thd	1024			DCLK
DCLK frequency @ Frame rate = 60Hz		fclk	Min.	Typ.	Max.	MHz
			44.9	51.2	63	
1 Horizontal Line		th	1200	1344	1400	DCLK
HSYNC pulse width	Min.	thpw	1			
	Typ.		-			
	Max.		140			
HSYNC blanking		thb	160	160	160	
HSYNC front porch		thfp	16	160	216	

Vertical input timing

Parameter	Symbol	Value			Unit
		Min.	Typ.	Max.	
Vertical display area	tvd	600			H
VSYNC period time	tv	624	635	750	H
VSYNC pulse width	tvpw	1	-	20	H
VSYNC Blanking (tvb)	tvb	23	23	23	H
VSYNC Front porch (tvfp)	tvfp	1	12	127	H



3.5 ELECTRO-OPTICAL CHARACTERISTICS

Parameter		Symbol	Condition	Min.	Typ.	Max.	Unit	Note	
Contrast Ratio (Center point)		C/R	-	500	800	-	-	Note(1)	
Luminance uniformity		U _w	θ = 0. Normal viewing angle B/L On Note(1)	75	80	-	%	Note(2)	
Response Time		Tr + Tf		-	25	40	ms	Note(3)	
Color Chromaticity (CIE 1931)	White	W _x			0.312			参考 值	Note(5)
		W _y			0.335				
	Red	R _x		0.571					
		R _y		0.352					
	Green	G _x	-0.02	0.345	+0.02				
		G _y		0.557					
Blue	B _x		0.148						
	B _y		0.128						
Viewing Angle	Hor.	∅ 3R	C/R≥10		85	-	Deg	Note(4)	
		∅ 9L			85	-			
	Ver.	∅ 12U			85	-			
		∅ 6D		-	85	-			



Note1 Definition of Contrast Ratio (CR):

$$\text{Contrast ratio (CR)} = \frac{\text{Luminance measured when LCD on the "White" state}}{\text{Luminance measured when LCD on the "Black" state}}$$

Note2: Definition of Luminance Uniformity: Active area is divided into 9 measuring areas (Shown in below), every measuring point is placed at the center of each measuring area.

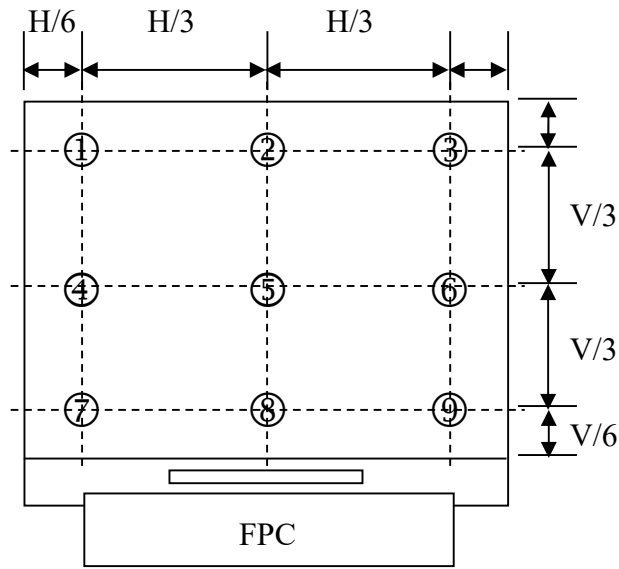

The spot locations for luminance measurement

$$\text{Luminance Uniformity} = \frac{B_{\min}}{B_{\max}} \times 100\%$$

B_{\max} : The measured maximum luminance of all measurement position.

B_{\min} : The measured minimum luminance of all measurement position.

Note 3: Definition of Response time: Sum of T_r and T_f

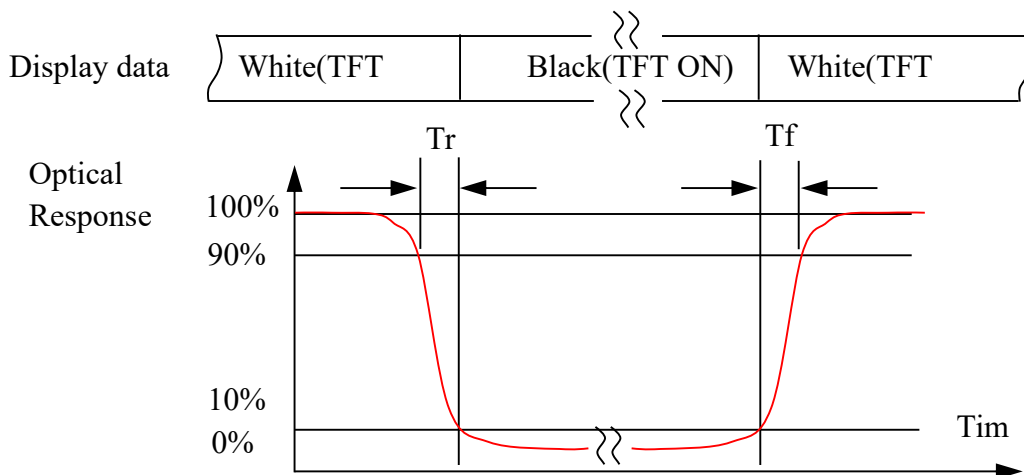



Note4. Definition of Viewing Angle: The viewing angle range that the $CR \geq 10$

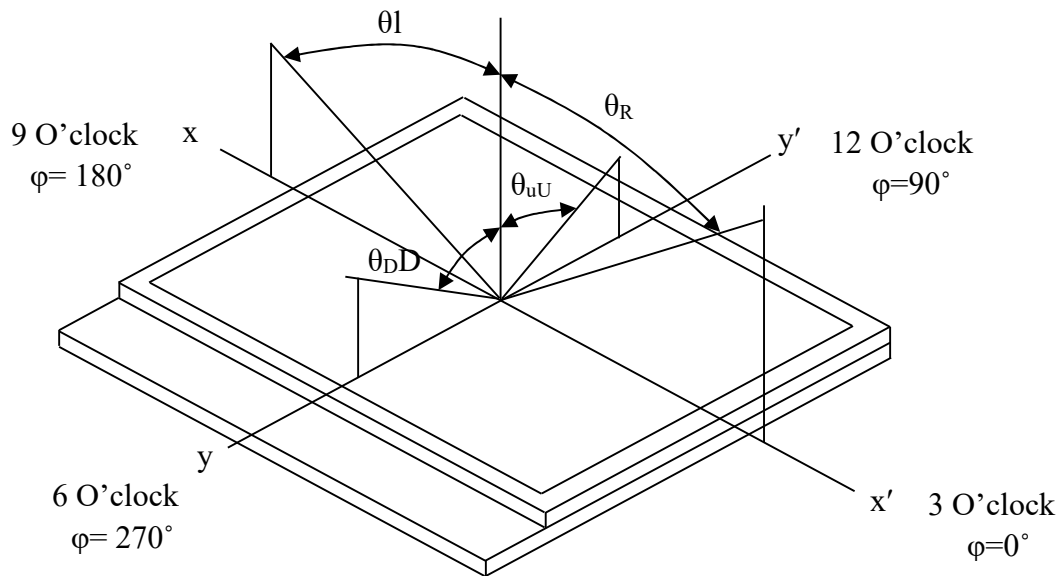

Note 5: Definition of Color Chromaticity (CIE 1931)

Color coordinate of white & red, green, blue at center point.



4. PCB 参数

4.1 技术参数

产品型号	HGPCB09FH-V9 版本: V11		
外形尺寸	114mm×70 mm×16.5mm (L×W×H)		
显示颜色	24 位 (3×8, 16.7M)		
显示屏接口	LVDS、		
控制范围	640×480~1920×1200等分辨率的LCD		
信号输入	输入信号类型	VGA、HDMI、AV	
	输入信号范围	HDMI 输入范围	PC (VGA / HDMI) 最高1920×1080 @ 60Hz, 1600×1200以下可达到75Hz
		VGA 输入范围	PC (VGA / HDMI) 最高1920×1080 @ 60Hz, 1600×1200以下可达到75Hz
支持可输入信号格式	参考附录A、附录B		
供电电压	最小: 10.8V	标称: 12V	最大: 13.2V
工作电流 ^{Note}	最小: 0.6A	标称: 1.0A	最大: 1.83A
待机功率	<0.8W		
显示屏电压	3.3V/5V/12V 可跳线选择		
最大显示屏负载能力 (常温)	1.69A@3.3V、2.32A@5V、3A@12V (12V 屏受限于电源供电能力)		
操作界面	可视化 OSD 操作界面		
通信接口	数字按键、红外 IR、I ² C master (预留)		
工作温度范围	-10~70℃; -30~70℃ (除主芯片外)		
工作湿度范围	10~95%RH (40℃, 95%RH)		
存储温度范围	-40~70℃		
存储湿度范围	10~100%RH		
工作环境大气压范围	70kPa~106kPa		
MTBF	>100000 小时		

Note: 针对 G170EG01VH

4.2 菜单结构

Main Menu (主菜单)	Submenu (子菜单)	Reset (出厂复位)	Description (描述)	
图像 (Picture)	信号亮度 (Brightness)	0~100	50	
	对比度 (Contrast)	0~100	50	
	背光 (BackLight)	0~100	50	
	色温 (Color Temp)	6500K	6500K	输入仅为 VGA 时可见
		9300K		输入仅为 VGA 时可见
		用户 (User)		输入仅为 VGA 时可见。RGB 可调、范围为 0~255
显示	自动调整 (AutoConfig)		输入仅为 VGA 时可见	



(Display)	自动颜色 (AutoColor)			输入仅为 VGA 时可见
	水平位置 (H Position)	0~100	50	输入仅为 VGA 时可见
	垂直位置 (V Position)	0~100	50	输入仅为 VGA 时可见
	相位 (Phase)	0~63	不定	输入仅为 VGA 时可见
	时钟 (Clock)	0~100	50	输入仅为 VGA 时可见
菜单 (OSD)	语言 (Language)	简体中文/English	简体中文	
	水平位置 (H Position)	0~100	50	
	垂直位置 (V Position)	0~100	50	
	时间 (OSD Timeout)	5~60	10	菜单无操作消失时间设定
	透明 (Transparent)	1/2/3/4/5/6/7/关 (Off)	关	当选择为 7 时, 透明度最高 当选择为关 (Off) 时, 则透明度为 0
系统 (System)	复位 (Reset)			
	蓝屏 (Blue Screen)	开 (On) / 关 (Off)	关 (Off)	选择为开 (On), 无信号时背景色为蓝色, 反之为黑色。
	锐度 (Sharpness)	0~100	50	
	热键 1 (Hotkey1)	无 (None) / 亮度调节 (Brightness) / 对比度调节 (Contrast) / 背光调节 (BackLight) / 自动调整 (AutoConfig) / 自动颜色 (AutoColor)	背光调节 (BackLight)	可根据需要选择热键定义。如果选择无 (None), 则无热键
	热键 2 (HotKey2)	无 (None) / 亮度调节 (Brightness) / 对比度调节 (Contrast) / 背光调节 (BackLight) / 自动调整 (AutoConfig) / 自动颜色 (AutoColor)	对比度调节 (Contrast)	可根据需要选择热键定义。如果选择无 (None), 则无热键
声音	保留			

4.3 数字按键说明

K1 (Source/EXIT)	信号源输入选择键/退出键
K2 (MENU)	主菜单按键, 确认按键
K3 (NC)	无功能
K4 (Left)	减小选项值 (-) / 参数调节按键、热键 1 (可定义)
K5 (Right)	增加选项值 (+) / 参数调节按键/确认键、热键 2 (可定义)
K6 (Power)	待机键

红外按键说明 (选配遥控器)

Menu	主菜单按键, 确认按键
← (Left)	减小选项值 (-) / 参数调节按键、热键 1 (可定义)
→ (Right)	增加选项值 (+) / 参数调节按键/确认键、热键 2 (可定义)
Source	退出键, 信号源输入选择键
Power	待机键



4.4 驱动板外观图

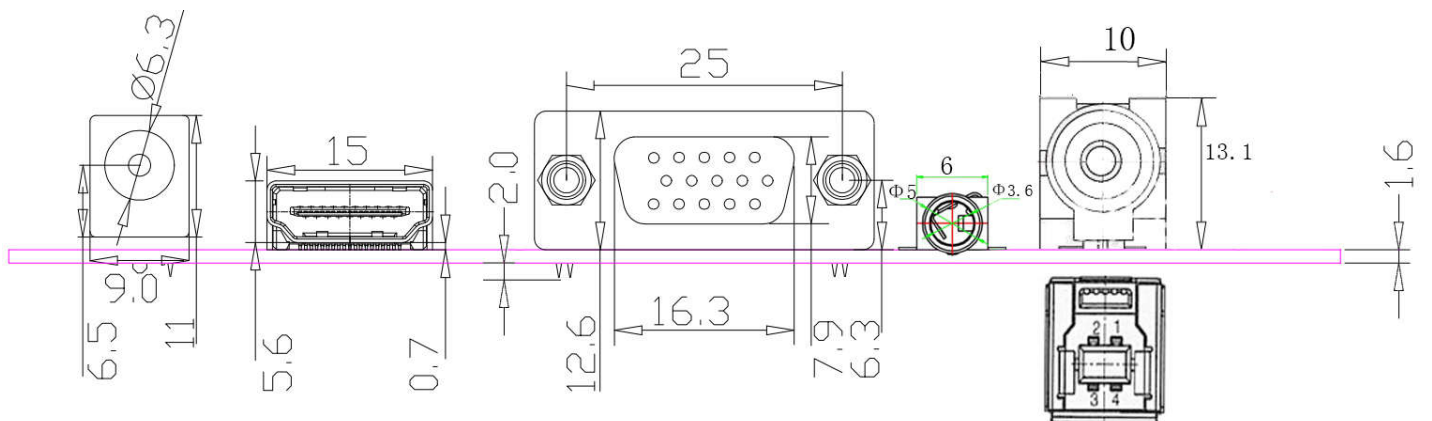
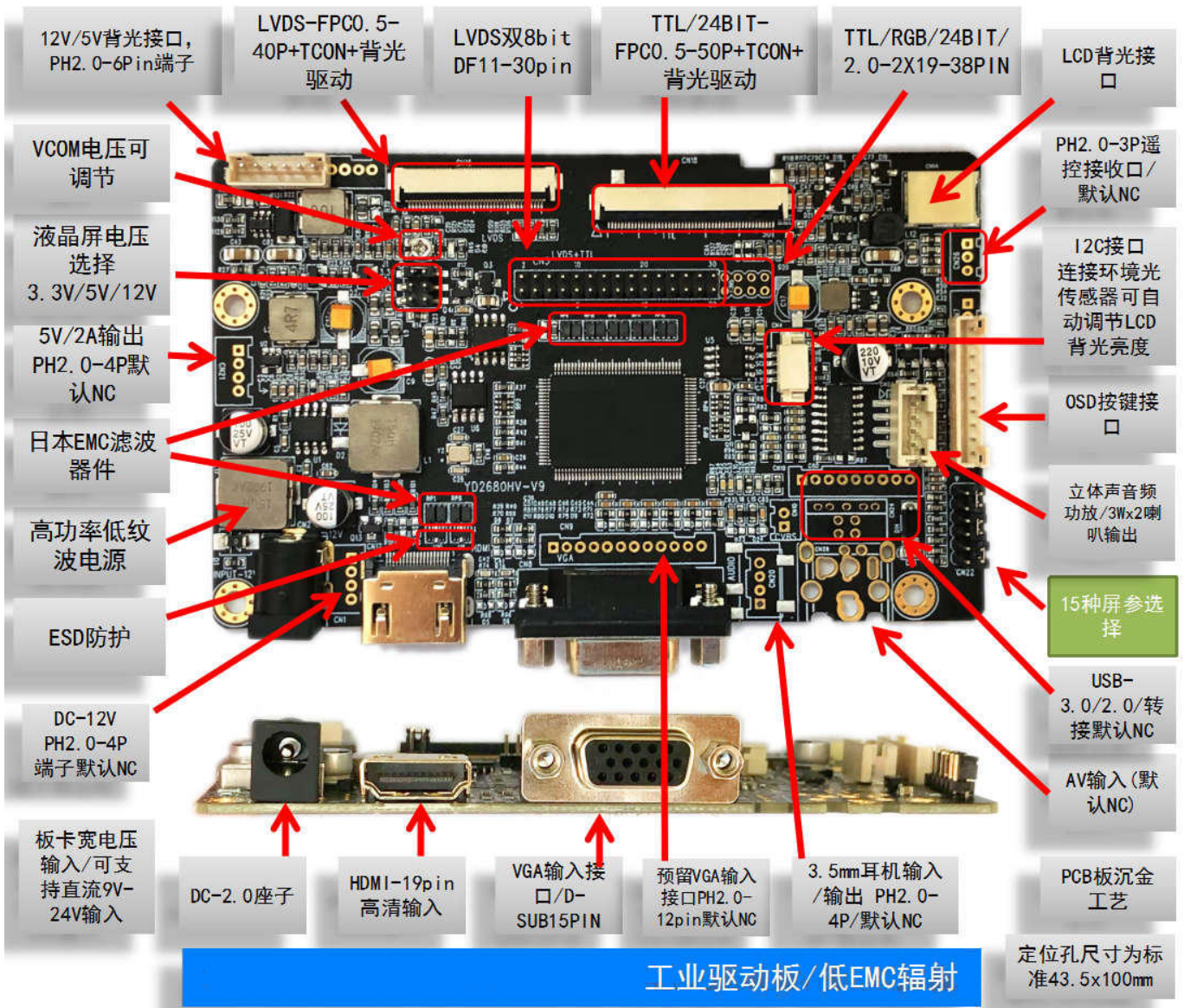



TOP VIEW:

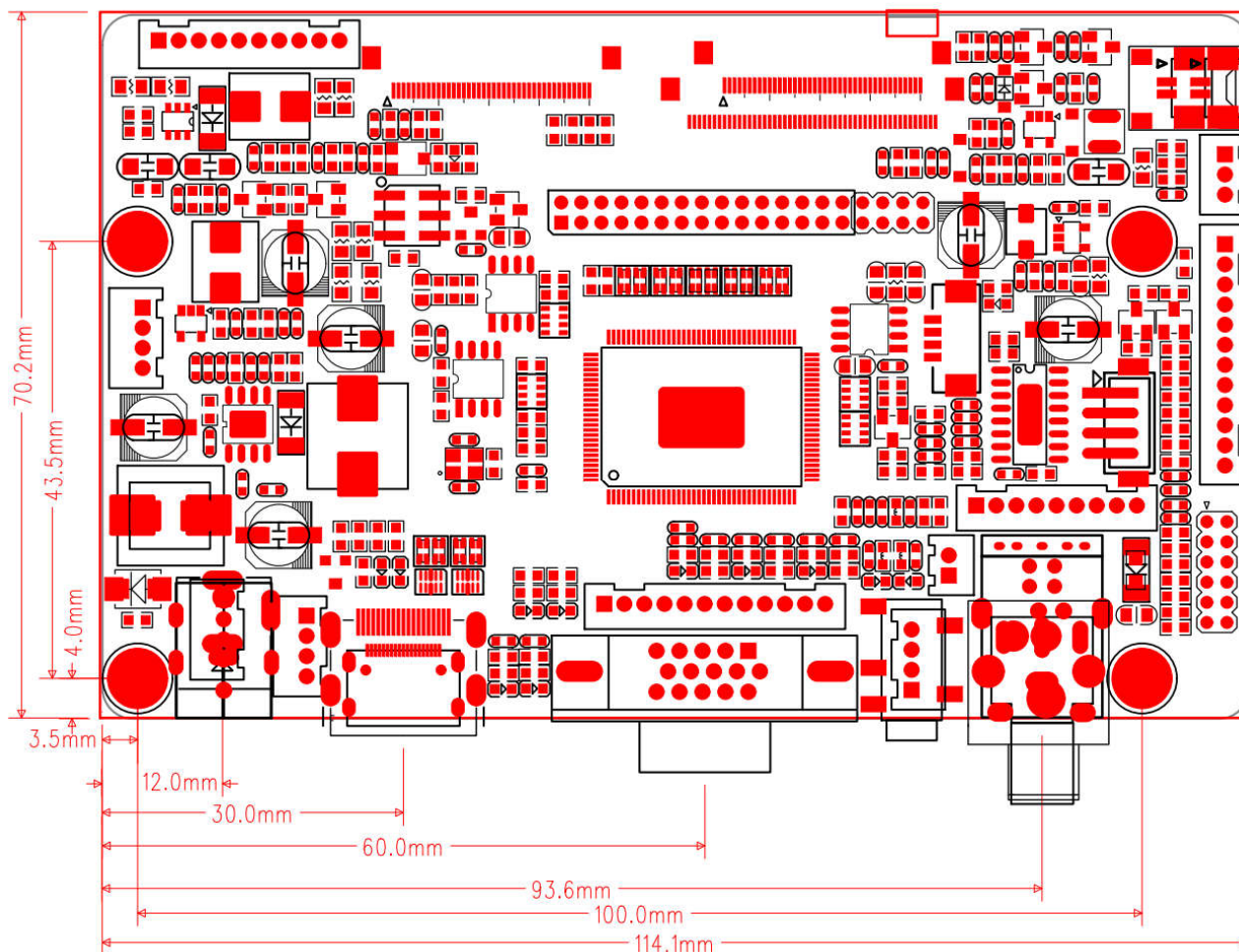

BOTTOM VIEW:

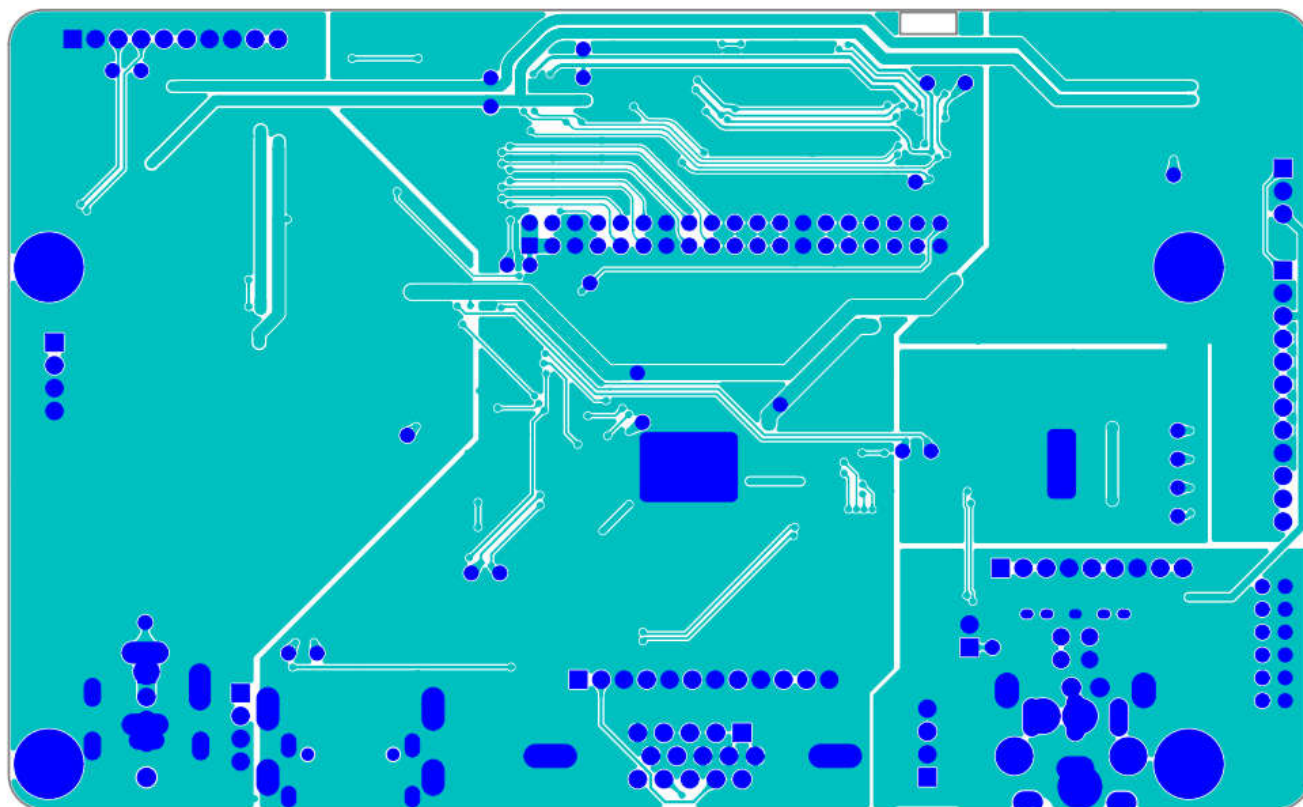

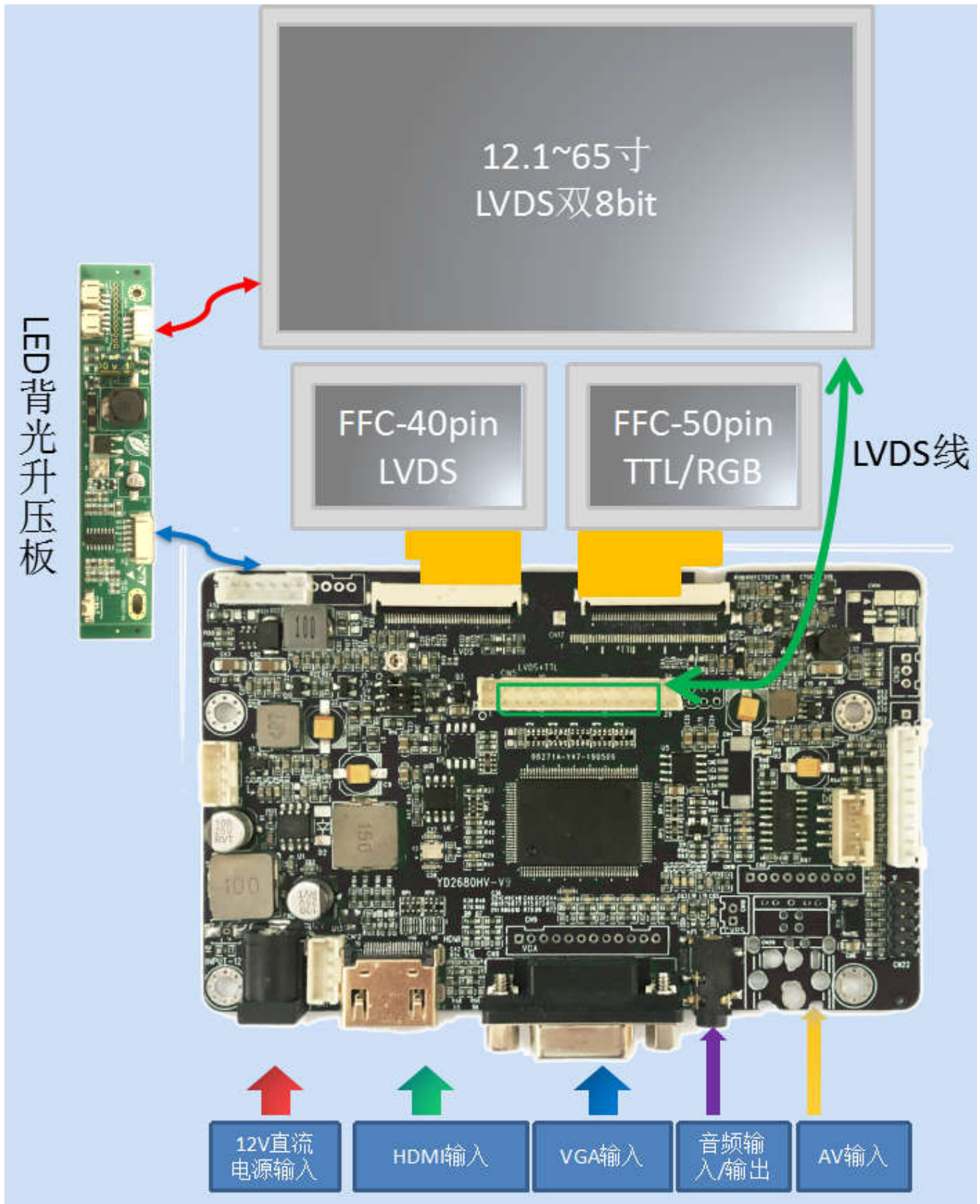



4.5 接口概览

接口	用途	连接器说明	备注
CN1	12V 直流电源输入	4P, 2.0Pitch, 单排, 180°, 插座 (JST/CVILUX)	
CN2	12V 直流电源输入	DC JACK, 内正外负, 正极外径 ϕ 2.0mm, 负极内径 ϕ 5.5mm (JST/CVILUX)	
CN3	逆变器接口	6P, 2.0Pitch, 单排, 180°, 插座	
CN12	HDMI 输入	HDMI-19pin, 90度, 台湾插座	
CN5	LVDS/TTL/输出接口	2 \times 15P, 2.0pitch, 双排, 180°, 插座 (JST/CVILUX)	
CN7	OSD 调节键盘接口	9P, 2.0Pitch, 单排, 180°, 插座 (JST/CVILUX)	
CN4	红外控制接口	3P, 2.0Pitch, 单排, 180°, 插座 (JST/CVILUX)	
CN8	VGA 输入标准插座	DB15FLC, 母头, 90°, 蓝色, 带螺丝 (JST/CVILUX)	
CN9	VGA 输入替代插件	12P, 2.0Pitch, 单排, 180°, 插座 (JST/CVILUX)	
CN16	LVDS-FFC0.5mm-40pin	LVDS-40PIN, 默认 8bit 输出	
CN11	立体声/左右声道音频输出	4P, 2.0Pitch, 单排, 180°, 插座 (JST/CVILUX)	
CN14	LED 背光电压输出	中小尺寸 LED 背光输出; 高压插座端子 SM-POW-2P	
CN18	TTL-FFC0.5mm-40pin	TTL-40PIN 默认 8bit 输出	
CN17	TTL-FFC0.5mm-50pin	TTL-50PIN 默认 8bit 输出	
CN10	AV 输入	2P, 2.0Pitch, 单排, 180°, 插座 (JST/CVILUX)	
J1	液晶屏供电选择	1-2 短路为 3.3V, 3-4 短路为 5V, 5-6 短路为 12V	

4.6 接口定义

标识: CN1 用途: 12V 直流电源输入

类型: 4P, 2.5Pitch, 单排, 180°, 插座 (JST/CVILUX), 白色,

接插件: PH2.0mm-4PIN 直插

引脚	符号	说明	引脚	符号	说明
1	+12V	+12V 直流电源输入 (\pm 10%)	2	+12V	+12V 直流电源输入 (\pm 10%)
3	GND	地	4	GND	地

标识: CN2 用途: 12V 直流电源输入

类型: 内正外负, 正极外径 ϕ 2.0mm, 负极内径 ϕ 5.5mm, 黑色

接插件: DC JACK (CVILUX)

引脚	符号	说明	引脚	符号	说明
1	+12V	+12V 直流电源输入 (\pm 10%)	2	GND	地
3	GND	地			

标识: CN5 用途: LVDS 信号输出

类型: 2 \times 15P, 2.0pitch, 180° 直插, 双排插座, 黑色

接插件: CI0130P1VD0 (CVILUX) /DF11-30DP-2DSA



引脚	符号	说明	引脚	符号	说明
1	VCC	3.3V/5V (±5%)	2	VCC	3.3V/5V (±5%)
3	VCC	3.3V/5V (±5%)	4	GND	地
5	GND	地	6	GND	地
7	TXO0-	奇通道的信道 1 输出负极	8	TXO0+	奇通道的信道 1 输出正极
9	TXO1-	奇通道的信道 2 输出负极	10	TXO1+	奇通道的信道 2 输出正极
11	TXO2-	奇通道的信道 3 输出负极	12	TXO2+	奇通道的信道 3 输出正极
13	GND	地	14	GND	地
15	TXOC-	奇通道的时钟输出负极	16	TXOC+	奇通道的时钟输出正极
17	TXO3-	奇通道的信道 4 输出负极	18	TXO3+	奇通道的信道 4 输出正极
19	TXE0-	偶通道的信道 1 输出负极	20	TXE0+	偶通道的信道 1 输出正极
21	TXE1-	偶通道的信道 2 输出负极	22	TXE1+	偶通道的信道 2 输出正极
23	TXE2-	偶通道的信道 3 输出负极	24	TXE2+	偶通道的信道 3 输出正极
25	GND	地	26	GND	地
27	TXEC-	偶通道的时钟输出负极	28	TXEC+	偶通道的时钟输出正极
29	TXE3-	偶通道的信道 4 输出负极	30	TXE3+	偶通道的信道 4 输出正极

标识: CN16 用途: LVDS 输出接口 默认 8bit 输出

接插件/类型: 上接触, FFC-0.5mm-40pin 或兼容型, 镀金/白色

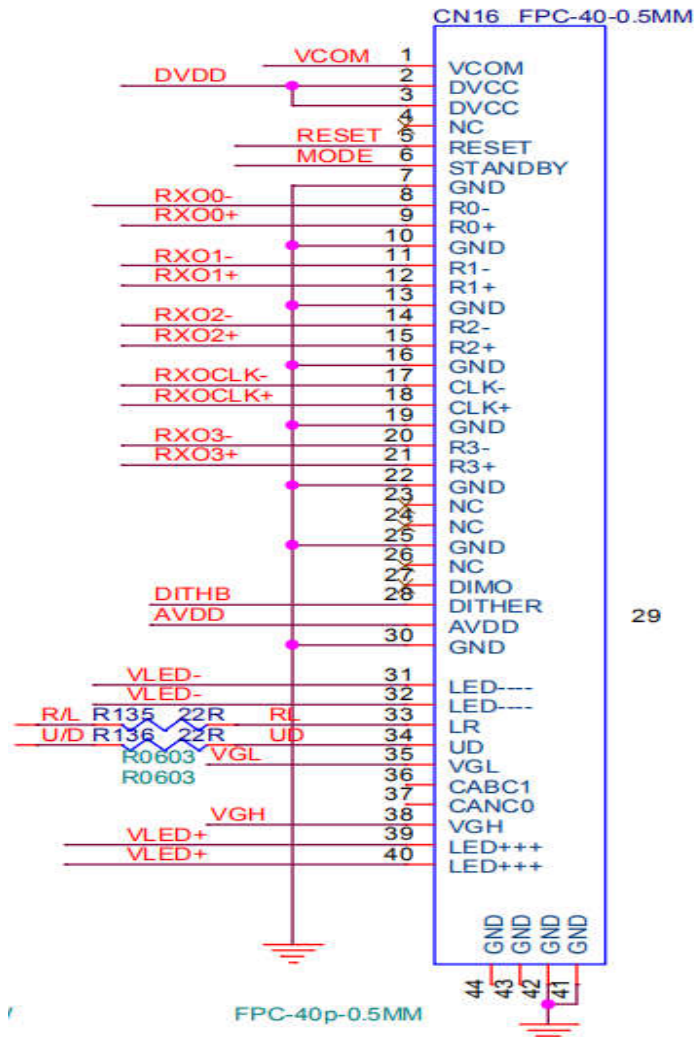



标识: CN17

用途: TTL 输出接口 默认 8bit 输出

类型: 上接触, FFC-0.5mm-50pin 或兼容型, 镀金/白色

Pin No.	Symbol	I/O	function	Remarks
1	VLED+	P	Power for LED backlight(anode)	
2	VLED+	P	Power for LED backlight(anode)	
3	VLED-	P	Power for LED backlight(Cathode)	
4	VLED-	P	Power for LED backlight(Cathode)	
5	GND	P	Power ground	
6	VCOM	I	Common voltage	
7	DVDD	P	Power for digital circuit	
8	MODE	I	DE/SYNC mode select. Normally pull high	MODE=1,DE mode, VS and HS must pull high; MODE=0, HSD/VSD mode, DE must be grounded
9	DE	I	DATA INPUT Enable	
10	VS	I	VERTICAL SYNC INPUT	
11	HS	I	Horizontal Sync Input	
12	B7	I	Blue data(MSB)	
13	B6	I	Blue data	
14	B5	I	Blue data	
15	B4	I	Blue data	
16	B3	I	Blue data	
17	B2	I	Blue data	
18	B1	I	Blue data	When input 18 bits RGB data, B1 must be grounded
19	B0	I	Blue data(LSB)	When input 18 bits RGB data, B0 must be grounded
20	G7	I	Green data(MSB)	
21	G6	I	Green data	
22	G5	I	Green data	
23	G4	I	Green data	
24	G3	I	Green data	
25	G2	I	Green data	
26	G1	I	Green data	When input 18 bits RGB data, G1 must be grounded
27	G0	I	Green data(LSB)	When input 18 bits RGB data, G0 must be grounded
28	R7	I	RED data(MSB)	
29	R6	I	RED data	
30	R5	I	RED data	
31	R4	I	RED data	
32	R3	I	RED data	
33	R2	I	RED data	
34	R1	I	RED data	When input 18 bits RGB data, R1 must be grounded
35	R0	I	RED data(LSB)	When input 18 bits RGB data, R0 must be grounded
36	GND	P	Power ground	
37	DCLK	I	Sample clock	Data shall be latched at the falling edge of DCLK
38	GND	I	Power ground	
39	L/R	I	Left/right selection	Selection of scanning mode
40	U/D	I	Up/down selection	Selection of scanning mode
41	VGH	P	Gate on voltage	
42	VGL	P	Gate off voltage	
43	AVDD	P	Power for analog circuit	
44	RESET	I	Global reset pin	Active low to enter reset state, suggest to connect with an RC reset circuit for stability. Normally pull high
45	NC	-	No connection	
46	VCOM	I	Common voltage	
47	DITHB	I	Dithering function enable control, normally pull high;	When DITHB=1,disable internal dithering function; When DITHB=0, enable internal dithering function;
48	GND	P	Power ground	
49	NC	-	No connection	
50	NC	-	No connection	



5. RELIABILITY TEST CONDITIONS

No	Test Item	Test Condition	STANDARD
1	High Temperature Storage	+70°C / 96Hours	1. Functional test is OK. Missing Segment, short, unclear segment, on-display, display abnormally and liquid crystal leak are un-allowed. 2. No low temperature bubbles, end seal loose and fall, frame rainbow.
2	Low Temperature Storage	-30°C / 96Hours	
3	High Temperature Operating	+60°C / 96Hours	
4	Low Temperature Operating	-20°C / 96Hours	
5	Thermal and cold shock	0°C↔+50°C x 10cycles (30min) (5min) (30min)	
6	Operate at High Temperature and Humidity	60°C x 90%RH / 24H	
7	Vibration Test	Frequency: 10Hz~55Hz~10Hz Amplitude:1.5mm, 2 hours for each direction of X, Y, Z	1. Function test is OK. 2. No glass crack, chipped glass, end seal loose and fall, epoxy frame crack and so on. 3. No structure loose and fall.
8	Dropping test	Drop to the ground from 1m height, 1 corner, 3 edges, 6 surfaces.	
9	ESD test	Contact: ±6KV Air: ±10KV 150PF/330Ω,5Points/pa nel,5times	The test results shall be subject to the whole machine test.

NOTE:

1. The reliability items will be fully performed in new sample qualification,
2. The reliability status will be tested as monitor during mass production. Individual reliability test shall be performed by lot, Moreover, the individual reliability item shall be decided according to reliability plan.
3. All samples are inspected after keeping in the room with normal temperature and humidity for 2 hours or above.
4. Vibration test: It is not necessary to test for those products without assembly frame, backlight, PCB and so on.
5. Dropping test: It is necessary for affirming new package.
6. For the high temperature and high humidity test, pure water of over 10 MΩ.cm should be used.
7. Each test item applies for test LCM only once. Then tested LCM cannot be used again in any other test item.
8. The quantity of LCM examination for each test item is 5pcs to 10pcs.



6. INSPECTION STANDARDS

6.1 AQL Sampling inspection standard

使用 GB/T 2828-2003 一般 II 水平, 采用正常检查一次抽样方式; 具体抽检方式参照《成品检验管理程序》、《抽样管理规范》

缺陷区分	AQL 允收水准
严重缺陷	0 收 1 退
重缺	0.4
轻缺	1.0

6.2 Inspect the condition

8.2.1 在 20—40W 日光灯的照明条件下, 样品离检查者眼睛约 30cm 处进行检查。检验方向以垂直线前后左右 45° (以时钟 3 点、6 点、9 点、12 点)

8.2.2 检验者视力需达到标准视力 1.0 以上。

8.2.3 检验者需戴静电手环、两手八个手指套。

8.2.4 外观检验者以目视检查或以菲林对比卡比对。

8.2.5 电性测试使用电测测架, 主板, 电源线及单片机。

8.2.6 若标准与规格书不符时, 以产品发行之规格书特殊检验规格、工程变更为准

8.2.7 辉色度检测请参照样品, 检测方法依照辉色度检验标准。

8.2.8 电测检验环境: 照度为 200LUX 以下, 外观检验环境: 照度为 600LUX-1000LUX, 检验时间: 1 秒-3 秒。

8.2.9 检验工具: 电测测架, 主板, 电源线及单片机, 菲林对比卡, 游标卡尺, 放大镜, 实体显微镜 (必要时) 等等。

6.3 Judgment criterion

小尺寸点、线判定标准: (6.2 寸以内)

1	点状缺陷 (磨伤、异物、针孔、凹痕、缺膜、气泡、白点、彩点、脏点)		判定 (A /B/C 区)	$D \leq 0.10$, 忽略不计, 但密集型不允许	MI	OK
				$0.1 < D \leq 0.15$, $ds \geq 10$		$N \leq 2$
				$0.15 < D \leq 0.2$, $ds \geq 10$		$N \leq 1$
				LCD 亮点: $0.15 < D$		$N \leq 1$
				$D > 0.2$		NG
			判定 (D 区)	同背面丝印油墨区杂质判定标准		
			注: 1) D 区的点状缺陷需在不影响 CTP 功能、客户组装及整机的外观的情况下, 判定 OK		MI	
2	线状缺陷 (磨伤、无感划伤、毛屑、纤维等)		判定 (A /B/C 区)	$W \leq 0.03mm$, $L \leq 3mm$, $ds \geq 10$	MI	$N \leq 2$
				$0.03mm < W \leq 0.05mm$, $L \leq 3mm$, $ds \geq 10$		$N \leq 1$
				$W > 0.05mm$ 或 $L > 3mm$		NG



中尺寸点、线判定标准：(6.2~8寸以内)

1	点状缺陷 (磨伤、异物、针孔、凹痕、缺膜、气泡、白点、彩点、脏点)		判定(A/B/C区)	$D \leq 0.10$, 忽略不计, 但密集型不允许	MI	OK
				$0.15 < D \leq 0.25, ds \geq 10$		$N \leq 2$
$0.25 < D \leq 3, ds \geq 10$	$N \leq 1$					
LCD亮点: $0.2 < D$	$N \leq 1$					
$D > 0.3$	NG					
判定(D区)	同背面丝印油墨区杂质判定标准					
注: 1) D区的点状缺陷需在不影响CTP功能、客户组装及整机的外观的情况下, 判定OK					MI	
2	线状缺陷 (磨伤、无感划伤、毛屑、纤维等)		判定(A/B/C区)	$W \leq 0.03mm, L \leq 3mm, ds \geq 10$	MI	$N \leq 2$
				$0.03mm < W \leq 0.05mm, L \leq 3mm, ds \geq 10$		$N \leq 1$
				$W > 0.05mm$ 或 $L > 3mm$		NG

大尺寸点、线判定标准：(8.1~13.3寸以内)

1	点状缺陷 (磨伤、异物、针孔、凹痕、缺膜、气泡、白点、彩点、脏点)		判定(A/B/C区)	$D \leq 0.1$, 忽略不计, 但密集型不允许	MI	OK
				$0.15 < D \leq 0.3, ds \geq 10$		$N \leq 2$
$0.3 < D \leq 0.35, ds \geq 10$	$N \leq 1$					
LCD亮点: $0.25 < D$	$N \leq 1$					
$D > 0.35$	NG					
判定(D区)	同背面丝印油墨区杂质判定标准					
注: 1) D区的点状缺陷需在不影响CTP功能、客户组装及整机的外观的情况下, 判定OK					MI	
2	线状缺陷 (磨伤、无感划伤、毛屑、纤维等)		判定(A/B/C区)	$W \leq 0.05mm, L \leq 5mm, ds \geq 10$	MI	$N \leq 2$
				$0.05mm < W \leq 0.07mm, L \leq 5mm, ds \geq 10$		$N \leq 1$
				$W > 0.07mm$ 或 $L > 5mm$		NG



7. PACKAGE DRAWING

