



# SPECIFICATION FOR TFT LCD MODULE

CUSTOMER : \_\_\_\_\_

CUSTOMER MODULE : \_\_\_\_\_

HG MODEL : HG070WS018

Preliminary Specification

Final Specification

Customer Confirmation column:

Approved by : \_\_\_\_\_ Dept. : \_\_\_\_\_ Data : \_\_\_\_\_

Please return one of the copies of the specification with your signature to us within two weeks after you receive this document. If it is not returned, we will assume that you agree to the entire contents of this specification document.

Designed by	Checked by	Approved by



## Revision History

Version NO.	DATE	Description	Remak
V1.0	2020.04.09	FIRST ISSUE	



## CONTENTS

No.	ITEM	PAGE
1.	GENERAL INFORMATION	4
2.	DIAGRAM FOR LCM	5
3.	I/O CONNECTION & BLOCK DIAGRAM	6~7
4.	ABSOLUTE MAXIMUM RATINGS	8
5.	ELECTRICAL CHARACTERISTICS	9~12
6.	ELECTRO-OPTICAL CHARACTERISTICS	13~15
7.	RELIABILITY TEST CONDITIONS	16
8.	INSPECTION STANDARDS	17~18
9.	PACKAGE DRAWING	19



## 1. GENERAL INFORMATION

### 1.1 features

- 1) Structure: TFT PANNEL+IC+FPC+BL
- 2) IPS Type LCD 1024 dot-segment and 600 dot-common outputs
- 3) 16.7M Color can be selected by software
- 4) White LED back light
- 5) LVDS interface
- 6) Operation Temperature : -20~60℃
- 7) Storage Temperature : -30~70℃
- 8) CTP cover lens : -/
- 9) CTP structure : -/
- 10) LED life time: -/

### 1.2 General specification

Item of	Contents	Unit
Panel Size	7.0	inch
LCD Type	a-si/TRANSMISSIVE	/
Display mode	Normally Black	/
Pixel arrangement	1024*3 (RGB) *600	Dots
Pixel pitch (W*H)	0.1506 (W) x0.1432 (H)	mm
Active Area	154.2144 (H) x 85.92 (V)	Mm
Module area (W*H*T)	165 (W) × 100 (H) × 5.5 (T)	Mm
Recommended Viewing Direction	ALL	0' clock
Interface	LVDS	/
Luminance for LCM	400	cd/m <sup>2</sup>
Weight	TBD	g





## 3. I/O CONNECTION & BLOCK DIAGRAM

### 3.1 I/O connection

LCM	Symbol	I/O	Description
1	NC	-	NC
2-3	VDD	P	Power supply for digital circuits and IO pads(3.3V)
4	GND	P	Power Ground
5	RESET	I	Global reset pin
6	STBYB	I	Standby mode & Normally pulled high
7	GND	P	Power Ground
8	RXIN0-	I	Negative LVDS differential data inputs
9	RXIN0+	I	Positive LVDS differential data inputs
10	GND	P	Power Ground
11	RXIN1-	I	Negative LVDS differential data inputs
12	RXIN1+	I	Positive LVDS differential data inputs
13	GND	P	Power Ground
14	RXCLKIN-	I	Negative LVDS differential clock inputs
15	RXCLKIN+	I	Positive LVDS differential clock inputs
16	GND	P	Power Ground
17	RXIN2-	I	Negative LVDS differential data inputs
18	RXIN2+	I	Positive LVDS differential data inputs
19	GND	P	Power Ground
20	RXIN3-	I	Negative LVDS differential data inputs
21	RXIN3+	I	Positive LVDS differential data inputs
22	GND	P	Power Ground
23-24	NC	-	NC
25	GND	P	Power Ground
26-29	NC	-	NC
30	GND	P	Power Ground
31	LED-	P	Power supply for LED-
32	NC	-	NC
33	SHLR	I	Horizontal inversion
34	UPDN	I	Vertical inversion
35-38	NC	-	NC
39	LED+	P	Power supply for LED+
40-50	NC	-	NC

I: Input; O: Output; P: Power



## 3.2 block diagram

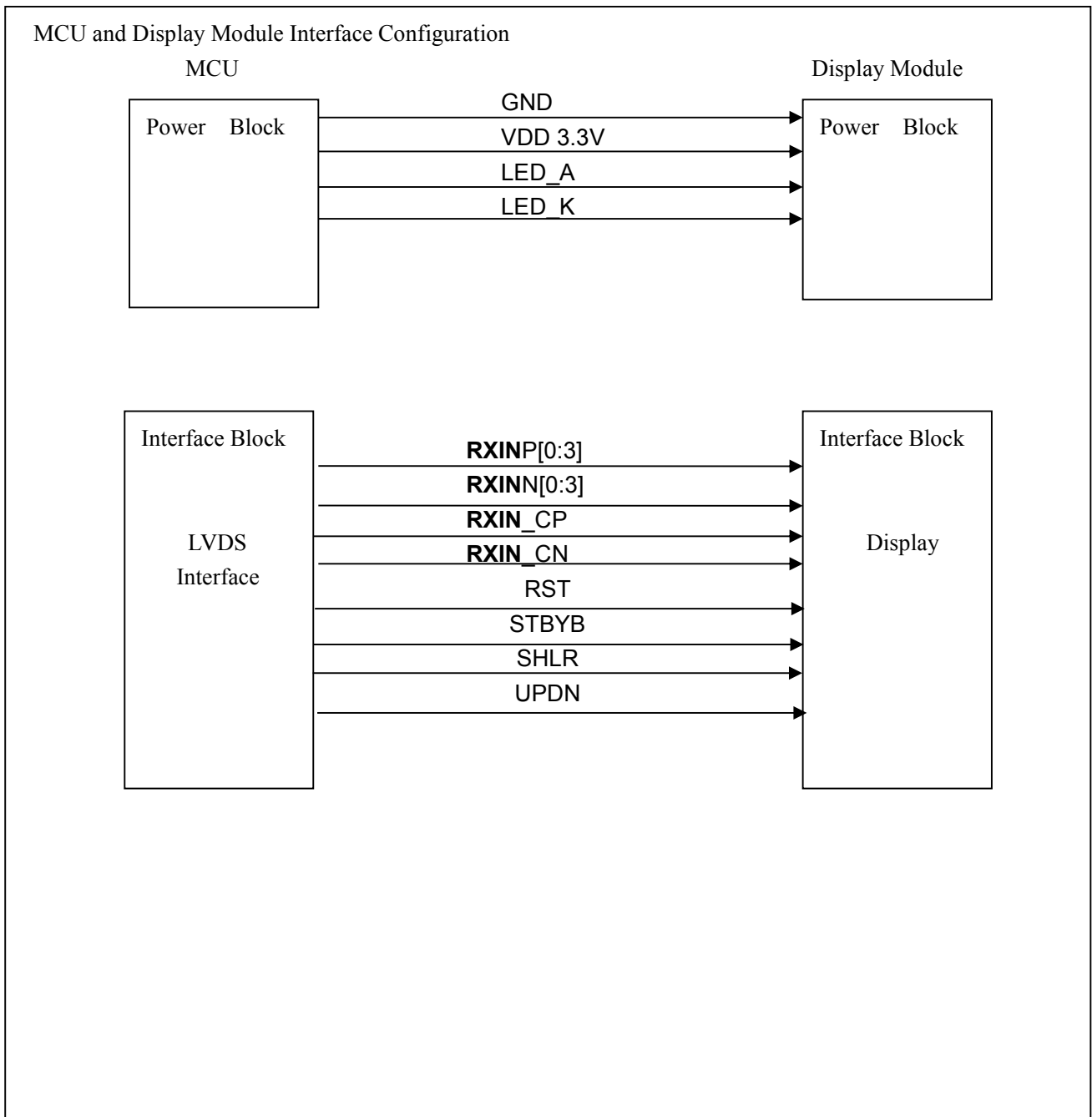



## 4. ABSOLUTE MAXIMUM RATINGS

(GND=AGND=0V)

Parameter of absolute maximum ratings 参数	Symbol 符号	Min 最小值	Max 最大值	Unit 单位
Power supply voltage	VDD	3	3.6	V
Backlight forward current	I <sub>LED</sub>	-0.001	30	mA(For each led)
Reverse Voltage	V <sub>R</sub>	-	10	V
Operating temperature	T <sub>op</sub>	-20	60	°C
Storage temperature	T <sub>st</sub>	-30	70	°C
Humidity	RH	-	90%(Max)/60°C	RH





## 5. ELECTRICAL CHARACTERISTICS

### 5.1 Typical Operation Conditions

Item	Symbol	Values			Unit	Remarks
		Min.	Typ.	Max.		
Power Voltage Supply	VDD	3	3.3	3.6	V	
Backlight Forward Voltage	Vf	-	18	19.2	V	-
LED Forward Current	If	-	160	-	mA	Note

Note: The "LED life time" is defined as the module brightness decrease to 50% of original brightness at  $I_L=20\text{mA}$  (for each led). The LED life time could be decreased if operating  $I_L$  is larger than 20mA

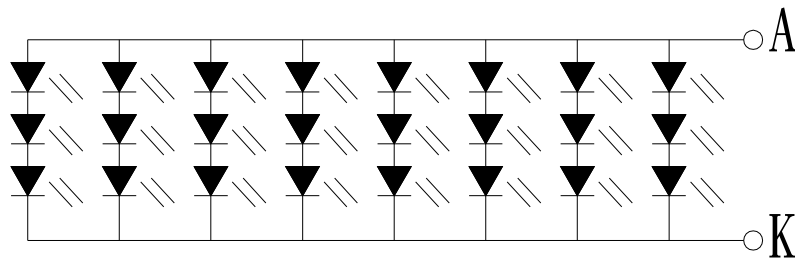

$$\text{LED } I_f : 20 * 8 = 160\text{mA}$$

$$\text{LED } V_f : 9.6\text{V (TYPE)}$$

Backlight LED Circuit



## 5.2 LVDS Interface DC Characteristic

LVDS DC Characteristic(TBD)  
 (VDD=VDD\_IF=1.8V, AVDD=8 to 13.5V, GND=AGND=GND\_IF=0V, TA=-20°C to 85°C)

Parameter	Symbol	Min.	Typ.	Max.	Unit	Condition
Differential input high threshold voltage	RxVTH	-	0.2	-	V	RxVCM=1.2V
Differential input low threshold voltage	RxVTL	-	-0.2	-	V	
Input voltage range(single-end)	RxVIN	0	-	1.8	V	
Differential input common mode voltage	RxVCM	$ V_{ID} /2$	1.2	$1.8 -  V_{ID} /2$	V	
Differential input voltage	$ V_{ID} $	0.2	0.4	0.6	V	
Differential input leakage current	ILCLVDS	-10	-	+10	$\mu$ A	
LVDS digital operating current	IDDLVDS	-	20	-	mA	Fclk=51.2Mhz, VDD=1.8V
LVDS digital standby current	ISTLVDS	-	10	-	$\mu$ A	Clock & all functions are stop
Differential input impedance	ZID	70	100	130	ohm	

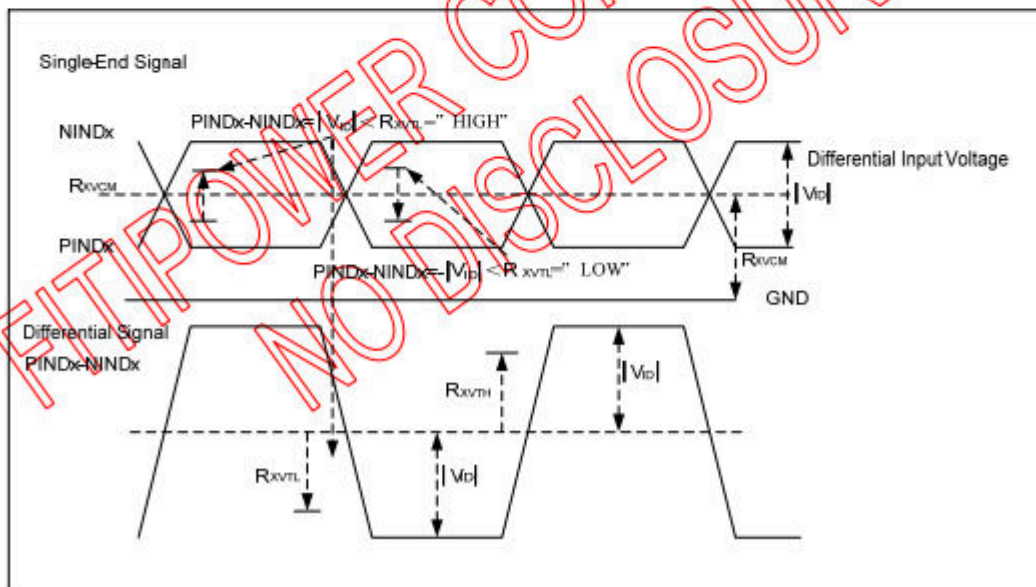

## 5.3 Power Block DC Characteristic

(VDD=VDD\_IF=1.8V, AVDD=8 to 13.5V, GND=AGND=GND\_IF=0V, TA=-20 to +85°C)

Parameter	Symbol	Min.	Typ.	Max.	Unit	Condition
Base drive current for PWM	IDRV	-	-	60	mA	DRVA =0.7V
DRV output voltage for PWM	VDRV	0	-	VDD	V	
Feedback voltage for PWM	VFB	1.1	1.2	1.3	V	
Duty cycle maximum	Dmax	-	-	85	%	
VCOM buffer input voltage	VCOMI	1	-	AVDD	V	
VCOM buffer output voltage	VCOMO	VCOMI-0.2	VCOMI	VCOMI+0.2	V	
VCOM buffer output current	IVCOM	-	-	10	mA	VCOMO=5V vs 4.9V



## 5.4 AC Electrical Characteristics

Parameter	Symbol	Condition	Min.	Typ.	Max.	Unit
Clock Frequency	RxFCLK		20	-	71	MHz
Input data skew margin	TRSKM	VID =400mV RxVCM=1.2V RxFCLK=71MHz	500			ps
Clock High Time	TLVCH			4/(7* RxFCLK)		ns
						ns
Clock Low Time	TLVCL			3/(7* RxFCLK)		ns
PLL wake-up-time	TenPLL				150	us

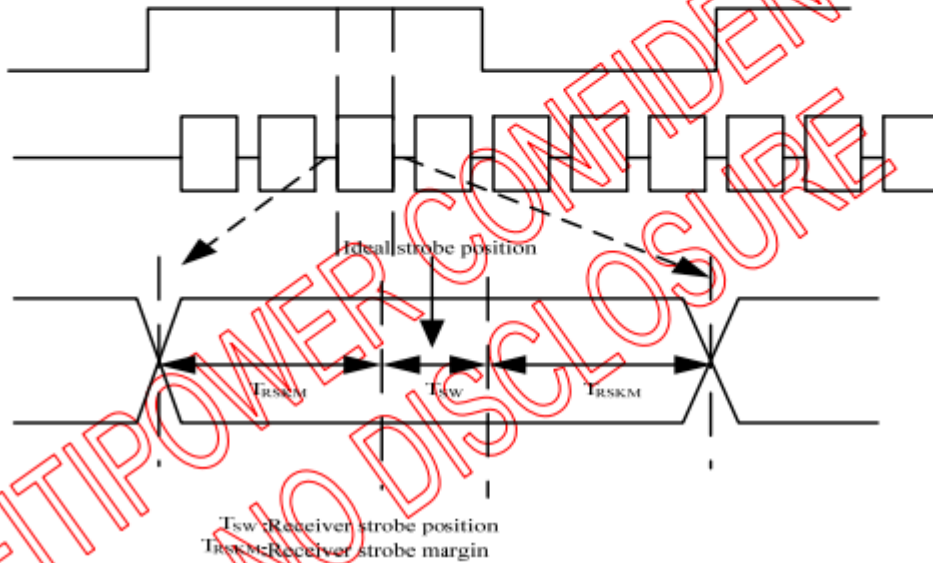

## 5.5 Power、Signal Sequence

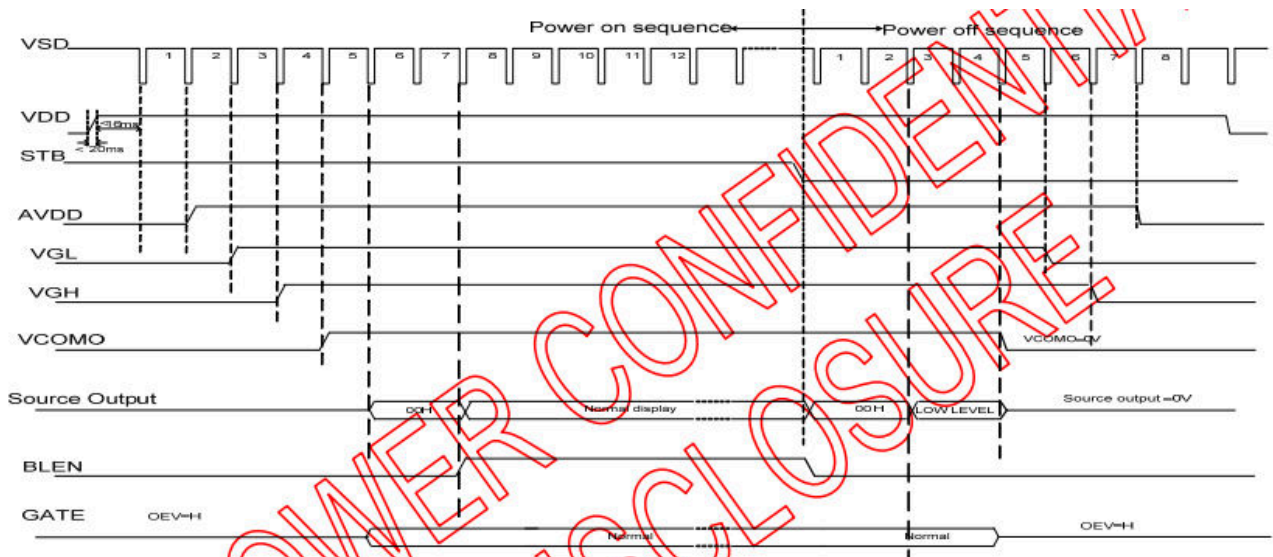



## 5.6 Enter and Exit Sleep Mode Sequence

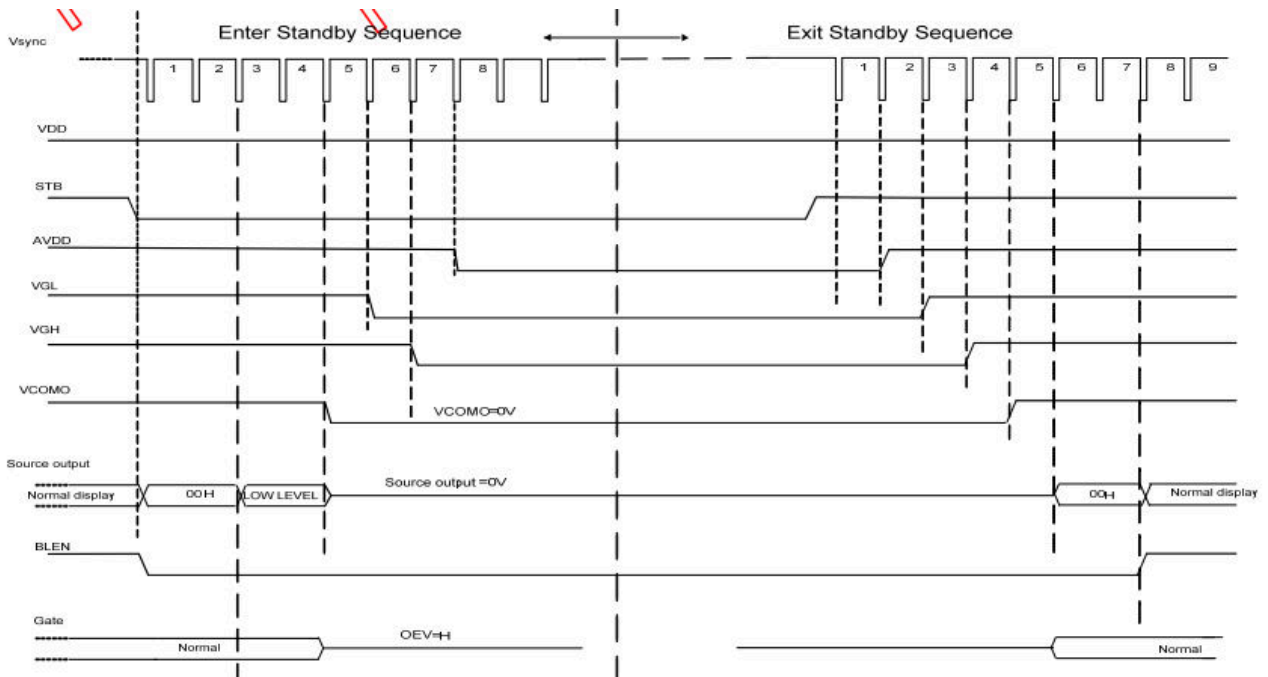



## 6. ELECTRO-OPTICAL CHARACTERISTICS

Parameter		Symbol	Condition	Min.	Typ.	Max.	Unit	Note	
Contrast Ratio (Center point)		C/R	-	500	800	-	-	Note(1)	
Luminance uniformity		$U_w$	$\theta = 0$ . Normal viewing angle B/L On Note(1)	75	80	-	%	Note(2)	
Response Time		$Tr + Tf$		-	25	40	ms	Note(3)	
Color Chromaticity (CIE 1931)	White	$W_x$			0.30			参考 值	Note(5)
		$W_y$			0.32				
	Red	$R_x$		0.571					
		$R_y$		0.352					
	Green	$G_x$	-0.02	0.345	+0.02				
		$G_y$		0.557					
	Blue	$B_x$		0.148					
		$B_y$		0.128					
Viewing Angle	Hor.	$\phi 3R$	$C/R \geq 10$		80	-	Deg	Note(4)	
		$\phi 9L$			80	-			
	Ver.	$\phi 12U$			80	-			
		$\phi 6D$		-	80	-			



Note1 Definition of Contrast Ratio (CR):

$$\text{Contrast ratio (CR)} = \frac{\text{Luminance measured when LCD on the "White" state}}{\text{Luminance measured when LCD on the "Black" state}}$$

Note2: Definition of Luminance Uniformity: Active area is divided into 9 measuring areas (Shown in below), every measuring point is placed at the center of each measuring area.

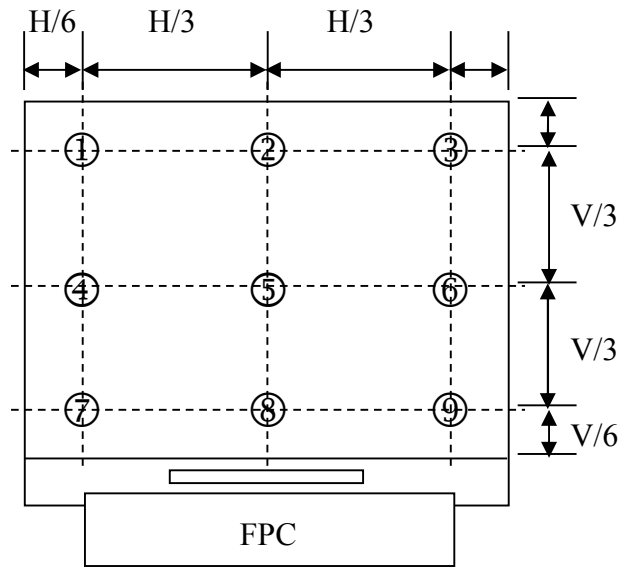

The spot locations for luminance measurement

$$\text{Luminance Uniformity} = \frac{H/6 B_{\min}}{V/6 B_{\max}} \times 100\%$$

$B_{\max}$ : The measured maximum luminance of all measurement position.

$B_{\min}$ : The measured minimum luminance of all measurement position.

Note 3: Definition of Response time: Sum of  $T_r$  and  $T_f$

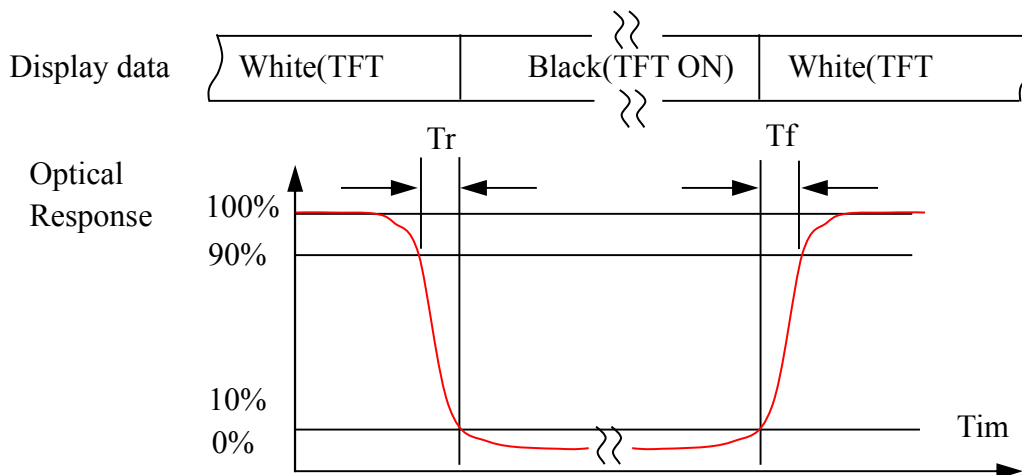



Note4. Definition of Viewing Angle: The viewing angle range that the  $CR \geq 10$

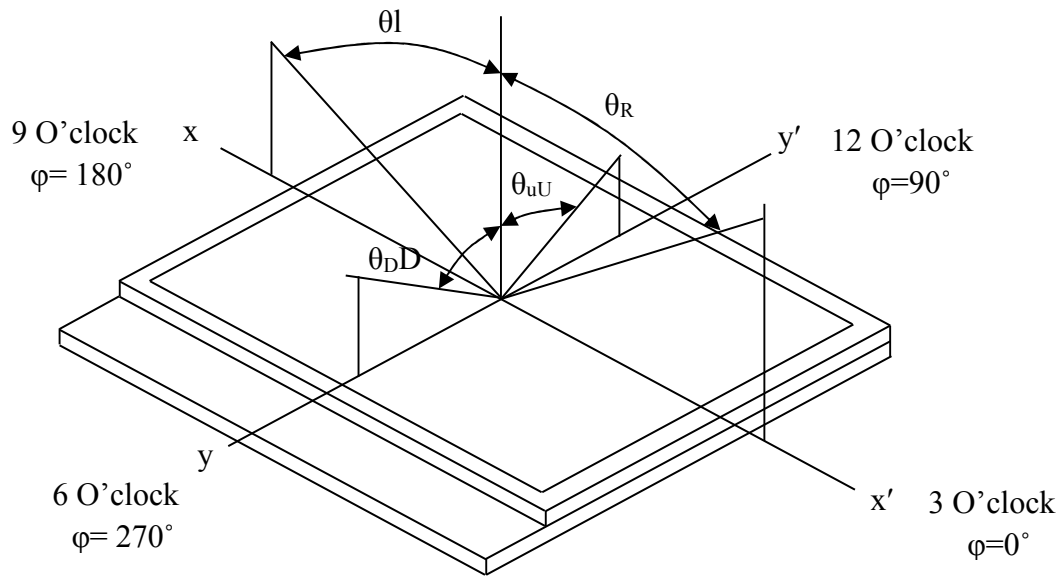

Note 5: Definition of Color Chromaticity (CIE 1931)

Color coordinate of white & red, green, blue at center point.



## 7. RELIABILITY TEST CONDITIONS

No	Test Item	Test Condition	STANDARD
1	High Temperature Storage	+70°C / 96Hours	1. Functional test is OK. Missing Segment, short, unclear segment, on-display, display abnormally and liquid crystal leak are un-allowed. 2. No low temperature bubbles, end seal loose and fall, frame rainbow.
2	Low Temperature Storage	-30°C / 96Hours	
3	High Temperature Operating	+60°C / 96Hours	
4	Low Temperature Operating	-20°C / 96Hours	
5	Thermal and cold shock	0°C↔+50°C x 10cycles (30min) (5min) (30min)	
6	Operate at High Temperature and Humidity	50°C x 90%RH / 24H	
7	Vibration Test	Frequency: 10Hz~55Hz~10Hz Amplitude:1.5mm, 2 hours for each direction of X, Y, Z	1. Function test is OK. 2. No glass crack, chipped glass, end seal loose and fall, epoxy frame crack and so on.
8	Dropping test	Drop to the ground from 1m height, 1 corner, 3 edges, 6 surfaces.	3. No structure loose and fall.
9	ESD test	Contact: ±6KV Air: ±10KV 150PF/330Ω,5Points/pa nel,5times	The test results shall be subject to the whole machine test.

### NOTE:

1. The reliability items will be fully performed in new sample qualification,
2. The reliability status will be tested as monitor during mass production. Individual reliability test shall be performed by lot, Moreover, the individual reliability item shall be decided according to reliability plan.
3. All samples are inspected after keeping in the room with normal temperature and humidity for 2 hours or above.
4. Vibration test: It is not necessary to test for those products without assembly frame, backlight, PCB and so on.
5. Dropping test: It is necessary for affirming new package.
6. For the high temperature and high humidity test, pure water of over 10 MΩ.cm should be used.
7. Each test item applies for test LCM only once. Then tested LCM cannot be used again in any other test item.
8. The quantity of LCM examination for each test item is 5pcs to 10pcs.





## 8. INSPECTION STANDARDS

### 8.1 AQL Sampling inspection standard

使用 GB/T 2828-2003 一般 II 水平, 采用正常检查一次抽样方式; 具体抽检方式参照《成品检验管理程序》、《抽样管理规范》

缺陷区分	AQL 允收水准
严重缺陷	0 收 1 退
重缺	0.4
轻缺	1.0

### 8.2 Inspect the condition

8.2.1 在 20—40W 日光灯的照明条件下, 样品离检查者眼睛约 30cm 处进行检查。检验方向以垂直线前后左右 45° (以时钟 3 点、6 点、9 点、12 点)

8.2.2 检验者视力需达到标准视力 1.0 以上。

8.2.3 检验者需戴静电手环、两手八个手指套。

8.2.4 外观检验者以目视检查或以菲林对比卡比对。

8.2.5 电性测试使用电测测架, 主板, 电源线及单片机。

8.2.6 若标准与规格书不符时, 以产品发行之规格书特殊检验规格、工程变更为准

8.2.7 辉色度检测请参照样品, 检测方法依照辉色度检验标准。

8.2.8 电测检验环境: 照度为 200LUX 以下, 外观检验环境: 照度为 600LUX-1000LUX, 检验时间: 1 秒-3 秒。

8.2.9 检验工具: 电测测架, 主板, 电源线及单片机, 菲林对比卡, 游标卡尺, 放大镜, 实体显微镜 (必要时) 等等。

### 8.3 Judgment criterion

小尺寸点、线判定标准: (6.2 寸以内)

1	点状缺陷 (磨伤、异物、针孔、凹痕、缺膜、气泡、白点、彩点、脏点)		判定 (A/B/C 区)	$D \leq 0.10$ , 忽略不计, 但密集型不允许	MI	OK
				$0.1 < D \leq 0.15$ , $ds \geq 10$		$N \leq 2$
				$0.15 < D \leq 0.2$ , $ds \geq 10$		$N \leq 1$
				LCD 亮点: $0.15 < D$		$N \leq 1$
				$D > 0.2$		NG
			判定 (D 区)	同背面丝印油墨区杂质判定标准		
			注: 1) D 区的点状缺陷需在不影响 CTP 功能、客户组装及整机的外观的情况下, 判定 OK		MI	
2	线状缺陷 (磨伤、无感划伤、毛屑、纤维等)		判定 (A/B/C 区)	$W \leq 0.03mm$ , $L \leq 3mm$ , $ds \geq 10$	MI	$N \leq 2$
				$0.03mm < W \leq 0.05mm$ , $L \leq 3mm$ , $ds \geq 10$		$N \leq 1$
				$W > 0.05mm$ 或 $L > 3mm$		NG



中尺寸点、线判定标准：（6.2 8 寸以内）

1	点状缺陷 (磨伤、异物、针孔、凹痕、缺膜、气泡、白点、彩点、脏点)		判定 (A /B/C 区)	$D \leq 0.10$ , 忽略不计, 但密集型不允许 $0.15 < D \leq 0.25$ , $ds \geq 10$ $0.25 < D \leq 3$ , $ds \geq 10$ LCD 亮点: $0.2 < D$ $D > 0.3$	MI	OK
			判定 (D 区)	同背面丝印油墨区杂质判定标准		N ≤ 2
			注: 1) D 区的点状缺陷需在不影响 CTP 功能、客户组装及整机的外观的情况下, 判定 OK		MI	N ≤ 1
2	线状缺陷 (磨伤、无感划伤、毛屑、纤维等)		判定 (A /B/C 区)	$W \leq 0.03mm$ , $L \leq 3mm$ , $ds \geq 10$ $0.03mm < W \leq 0.05mm$ , $L \leq 3mm$ , $ds \geq 10$	MI	N ≤ 2
				$W > 0.05mm$ 或 $L > 3mm$		N ≤ 1
						NG

大尺寸点、线判定标准：（8.1~13.3 寸以内）

1	点状缺陷 (磨伤、异物、针孔、凹痕、缺膜、气泡、白点、彩点、脏点)		判定 (A /B/C 区)	$D \leq 0.1$ , 忽略不计, 但密集型不允许 $0.15 < D \leq 0.3$ , $ds \geq 10$ $0.3 < D \leq 0.35$ , $ds \geq 10$ LCD 亮点: $0.25 < D$ $D > 0.35$	MI	OK
			判定 (D 区)	同背面丝印油墨区杂质判定标准		N ≤ 2
			注: 1) D 区的点状缺陷需在不影响 CTP 功能、客户组装及整机的外观的情况下, 判定 OK		MI	N ≤ 1
2	线状缺陷 (磨伤、无感划伤、毛屑、纤维等)		判定 (A /B/C 区)	$W \leq 0.05mm$ , $L \leq 5mm$ , $ds \geq 10$ $0.05mm < W \leq 0.07mm$ , $L \leq 5mm$ , $ds \geq 10$	MI	N ≤ 2
				$W > 0.07mm$ 或 $L > 5mm$		N ≤ 1
						NG



## 9. PACKAGE DRAWING

