



# SPECIFICATION FOR TFT LCD MODULE

CUSTOMER : \_\_\_\_\_

CUSTOMER MODULE : \_\_\_\_\_

HL MODEL : HG097QX003T01

Preliminary Specification

Final Specification

Customer Confirmation column:

Approved by : \_\_\_\_\_ Dept. : \_\_\_\_\_ Date : \_\_\_\_\_

Please return one of the copies of the specification with your signature to us within two weeks after you receive this document. If it is not returned, we will assume that you agree to the entire contents of this specification document.

Designed by	Checked by	Approved by





## CONTENTS

No.	ITEM	PAGE
1.	GENERAL INFORMATION	4
2.	DIAGRAM FOR LCM+TP+PCBA	5
3.	LCM main parameters	6~10
4.	PCB 主要参数	11~13
5.	RELIABILITY TEST CONDITIONS	15
6.	INSPECTION STANDARDS	16~18
7.	PACKAGE DRAWING	18



## 1. GENERAL INFORMATION

### 1.1 features

- 1) Structure: TFT PANNEL+IC+FPC+BL+CTP+PCBA
- 2) IPS Type LCD 2048 dot-segment and 1536 dot-common outputs
- 3) 16.7M Color can be selected by software
- 4) White LED back light
- 5) EDP 4LANE interface
- 6) Operation Temperature : 0~50°C
- 7) Storage Temperature : -20~60°C
- 8) CTP cover lens : 3mm tempered glass
- 9) CTP structure : G+F+F, USB interface
- 10) LED life time: -/

### 1.2 General specification

Item of	Contents	Unit
Panel Size	9.7	inch
LCD Type	a-si/TRANSMISSIVE	/
Display mode	Normally Black	/
Pixel arrangement	2048*3(RGB)*1536	Dots
Pixel pitch (W*H)	0.192(H)*0.192 (V)	um
Active Area	196.608 (V) × 147.456 (H)	Mm
Module area (W*H*T)	367 (V) × 205 (H) × 21 (T)	Mm
Recommended Viewing Direction	ALL	0' clock
IC	-	/
Interface	4 lane EDP	/
Luminance for LCM+TP	400	cd/m2
NTSC	70	%
Weight	TBD	g



## 2. DIAGRAM FOR LCM+TP+PCBA

由 Autodesk 教育版产品制作

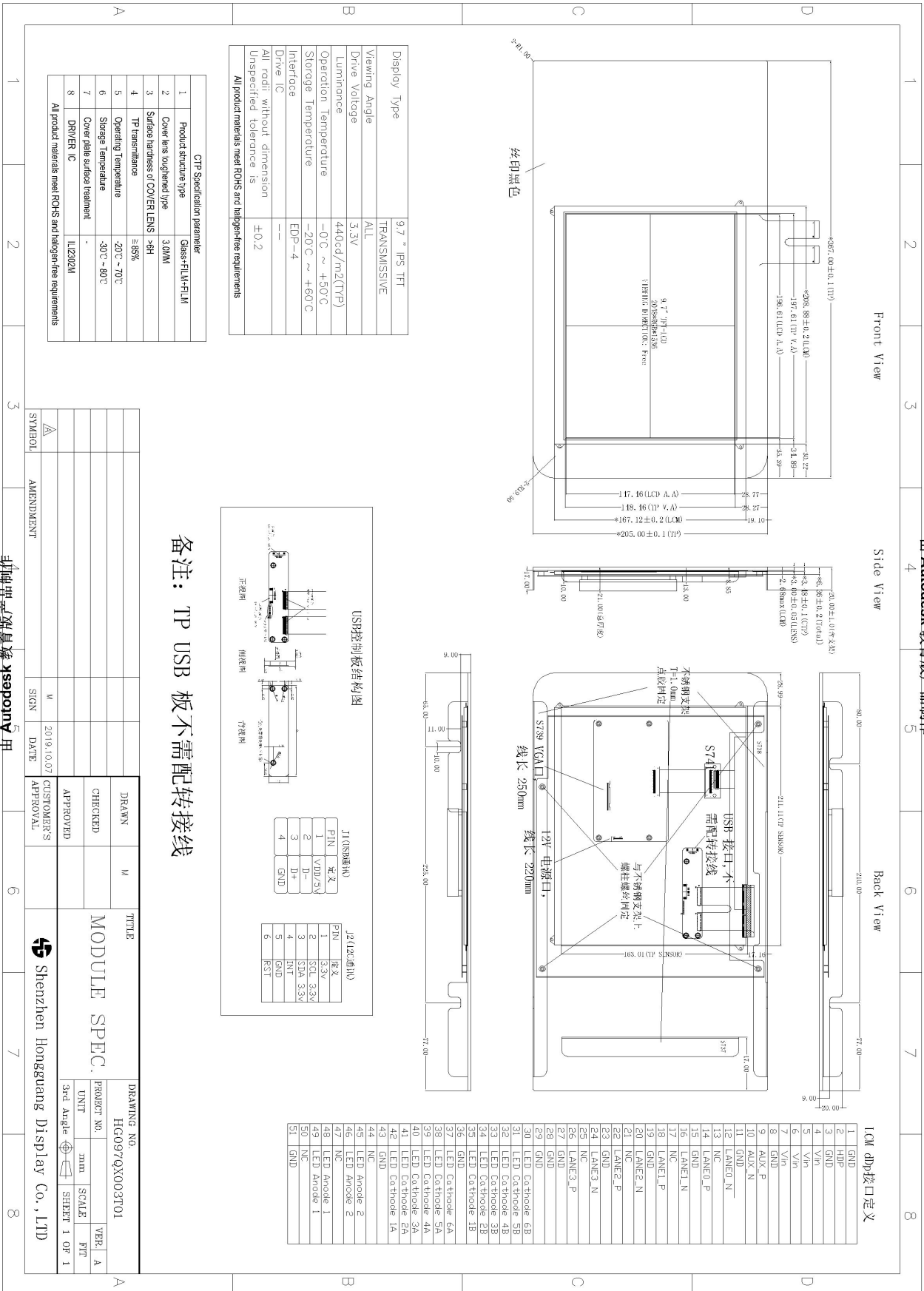

由 Autodesk 教育版产品制作



## 3. LCM main parameters

### 3.1 I/O connection

LCM Pin NO.	Symbol	Description
1	GND	Ground
2	HPD	Hot Plug detect
3	GND	Ground
4-7	Vin	VCC 3.3V
8	GND	Ground
9	AUX_P	True Signal Auxiliary Ch.
10	AUX_N	Complement Signal Auxiliary Ch.
11	GND	Ground
12	LANE0_N	Complement Signal Link Lane 0
13	NC	NC
14	LANE0_P	True Signal Link Lane 0
15	GND	Ground
16	LANE1_N	Complement Signal Link Lane 1
17	NC	NC
18	LANE1_P	True Signal Link Lane 1
19	GND	Ground
20	LANE2_N	Complement Signal Link Lane 2
21	NC	NC
22	LANE2_P	True Signal Link Lane 2
23	GND	Ground
24	LANE3_N	Complement Signal Link Lane 3
25	NC	NC
26	LANE3_P	True Signal Link Lane 3
27-29	GND	Ground
30	LED Cathode 6B	LED Cathode (Negative)
31	LED Cathode 5B	LED Cathode (Negative)
32	LED Cathode 4B	LED Cathode (Negative)
33	LED Cathode 3B	LED Cathode (Negative)
34	LED Cathode 2B	LED Cathode (Negative)
35	LED Cathode 1B	LED Cathode (Negative)
36	GND	Ground
37	LED Cathode 6A	LED Cathode (Negative)
38	LED Cathode 5A	LED Cathode (Negative)
39	LED Cathode 4A	LED Cathode (Negative)



40	LED Cathode 3A	LED Cathode (Negative)
41	LED Cathode 2A	LED Cathode (Negative)
42	LED Cathode 1A	LED Cathode (Negative)
43	GND	Ground
44	NC	NC
45	LED Anode 2	LED Cathode (Positive)
46	LED Anode 2	LED Cathode (Positive)
47	NC	NC
48	LED Anode 2	LED Cathode (Positive)
49	LED Anode 2	LED Cathode (Positive)
50	NC	NC
51	GND	Ground

## 3.2. ABSOLUTE MAXIMUM RATINGS

(GND=AGND=0V)

Parameter of absolute maximum ratings 参数	Symbol 符号	Min 最小值	Max 最大值	Unit 单位
Power supply voltage1	VCC	-0.3	4	V
Backlight forward current	I <sub>LED</sub>	-0.001	30	mA(For each led)
Operating temperature	T <sub>op</sub>	0	50	°C
Storage temperature	T <sub>st</sub>	-20	60	°C
Humidity	RH	-	90%(Max)/50°C	RH



## 3.3. ELECTRO-OPTICAL CHARACTERISTICS

Parameter		Symbol	Condition	Min.	Typ.	Max.	Unit	Note	
Contrast Ratio (Center point)		C/R	-	600	800	-	-	Note(1)	
Luminance uniformity		U <sub>w</sub>	θ = 0. Normal viewing angle B/L On  Note(1)	70	80	-	%	Note(2)	
Response Time		Tr + Tf		-	16	25	ms	Note(3)	
Color Chromaticity (CIE 1931)	White	W <sub>x</sub>			0.306			参考 值	Note(5)
		W <sub>y</sub>			0.320				
	Red	R <sub>x</sub>		0.642					
		R <sub>y</sub>		0.335					
	Green	G <sub>x</sub>	-0.02	0.315	+0.02				
		G <sub>y</sub>		0.609					
	Blue	B <sub>x</sub>		0.154					
		B <sub>y</sub>		0.054					
Viewing Angle	Hor.	∅ 3R	C/R≥10		80	-	Deg	Note(4)	
		∅ 9L			80	-			
	Ver.	∅ 12U			80	-			
		∅ 6D		-	80	-			





Note1 Definition of Contrast Ratio (CR):

$$\text{Contrast ratio (CR)} = \frac{\text{Luminance measured when LCD on the "White" state}}{\text{Luminance measured when LCD on the "Black" state}}$$

Note2: Definition of Luminance Uniformity: Active area is divided into 9 measuring areas (Shown in below), every measuring point is placed at the center of each measuring area.

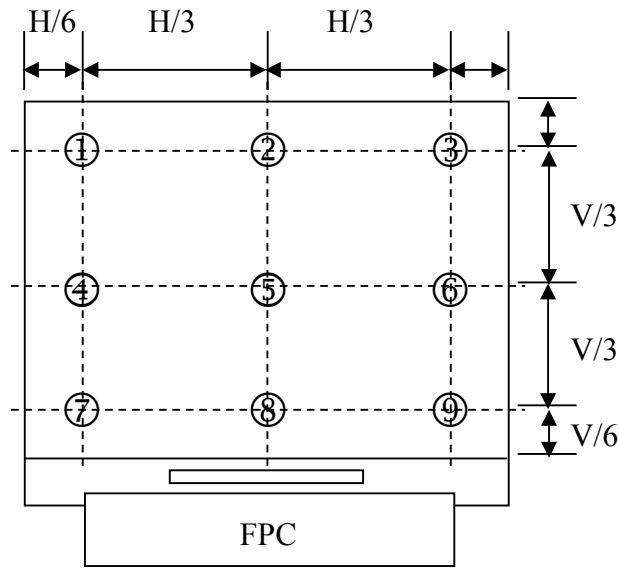

The spot locations for luminance measurement

$$\text{Luminance Uniformity} = \frac{H/6 \cdot B_{\min}}{V/6 \cdot B_{\max}} \times 100\%$$

$B_{\max}$ : The measured maximum luminance of all measurement position.

$B_{\min}$ : The measured minimum luminance of all measurement position.

Note 3: Definition of Response time: Sum of  $T_r$  and  $T_f$

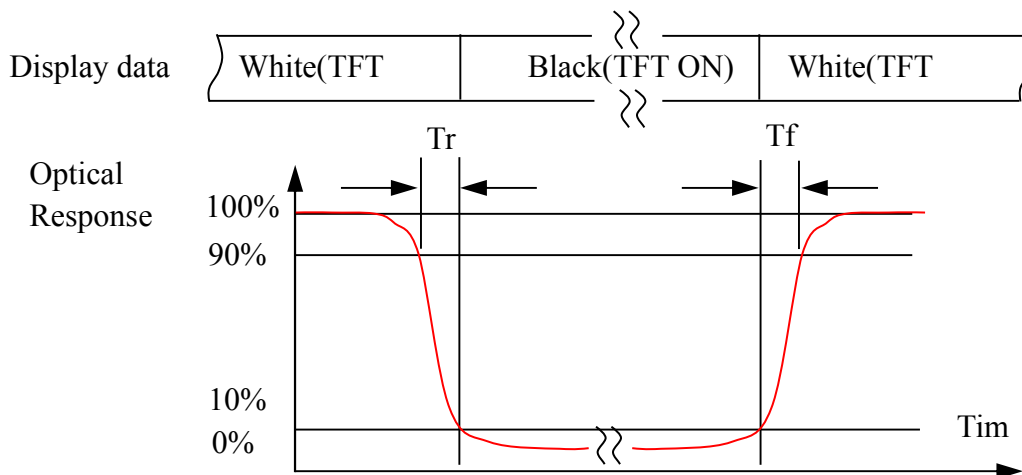



Note4.Definition of Viewing Angle: The viewing angle range that the  $CR \geq 10$

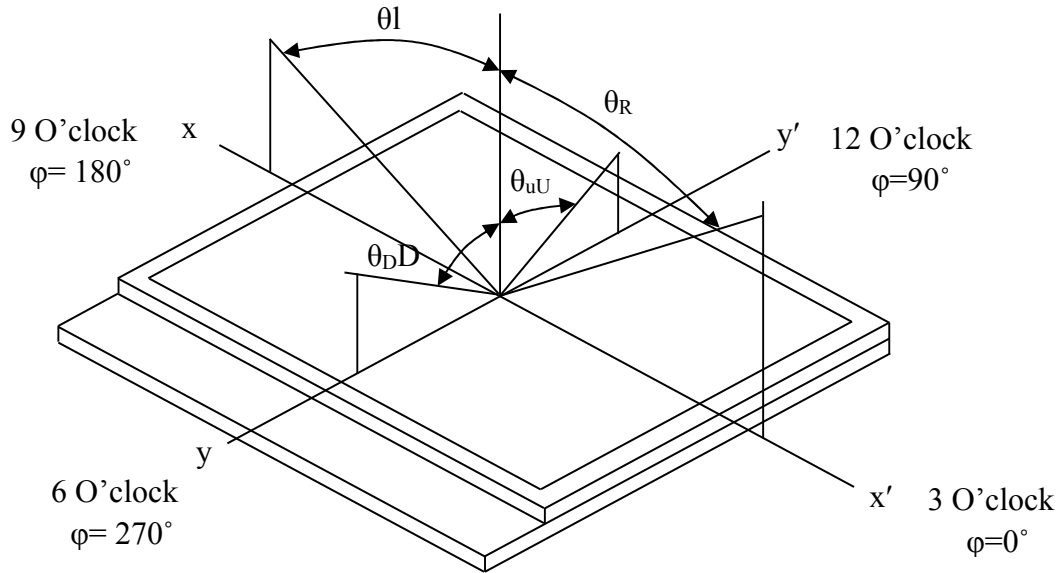

Note 5: Definition of Color Chromaticity (CIE 1931)  
Color coordinate of white & red, green, blue at center point.



## 4. PCB 参数

### 4.1 技术参数

外形尺寸	107mm×65 mm×16.5mm (L×W×H)		
显示颜色	24 位 (16.7M)		
显示屏幕接口	LVDS、EDP		
控制范围	480×272~2048×1536 等分辨率的 LCD		
信号输入	输入信号类型	VGA、HDMI、AV(默认 NC)	
	输入信号范围	HDMI 输入范围	PC (VGA / HDMI) 最高 2048×1536
		VGA 输入范围	PC (VGA / HDMI) 最高 2048×1536
供电电压	最小: 8V	标称: 12V	最大: 24V
工作电流	最小: 0.15A	标称: 0.17A	最大: 0.25A
待机功率	<0.5W		
显示屏电压	3.3V/5V/12V 可跳线选择		
最大显示屏负载能力(常温)	1.2A@3.3V、2.5A@5V、3.5A@12V (12V 屏受限于电源供电能力)		
操作界面	可视化 OSD 操作界面		
通信接口	数字按键、红外 IR		
工作温度范围	-20℃~70℃; -30℃~70℃ (除主芯片外)		
工作湿度范围	10~95%RH (40℃, 95%RH)		
存储温度范围	-40℃~70℃		
存储湿度范围	10~100%RH		
工作环境大气压范围	70kPa~106kPa		
MTBF	>100000 小时		

Note: (仅主板)



## 4.2 布局与尺寸图

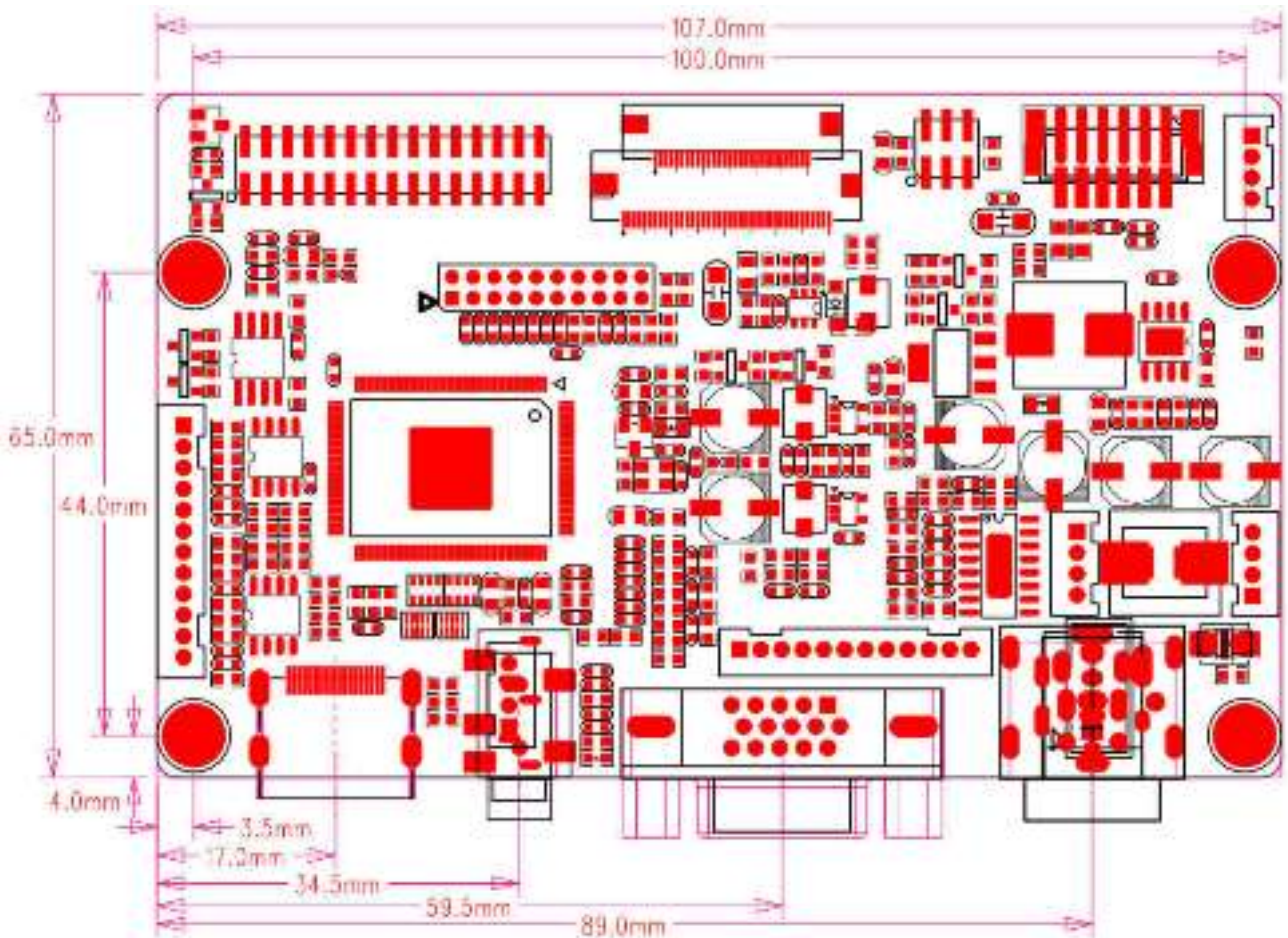
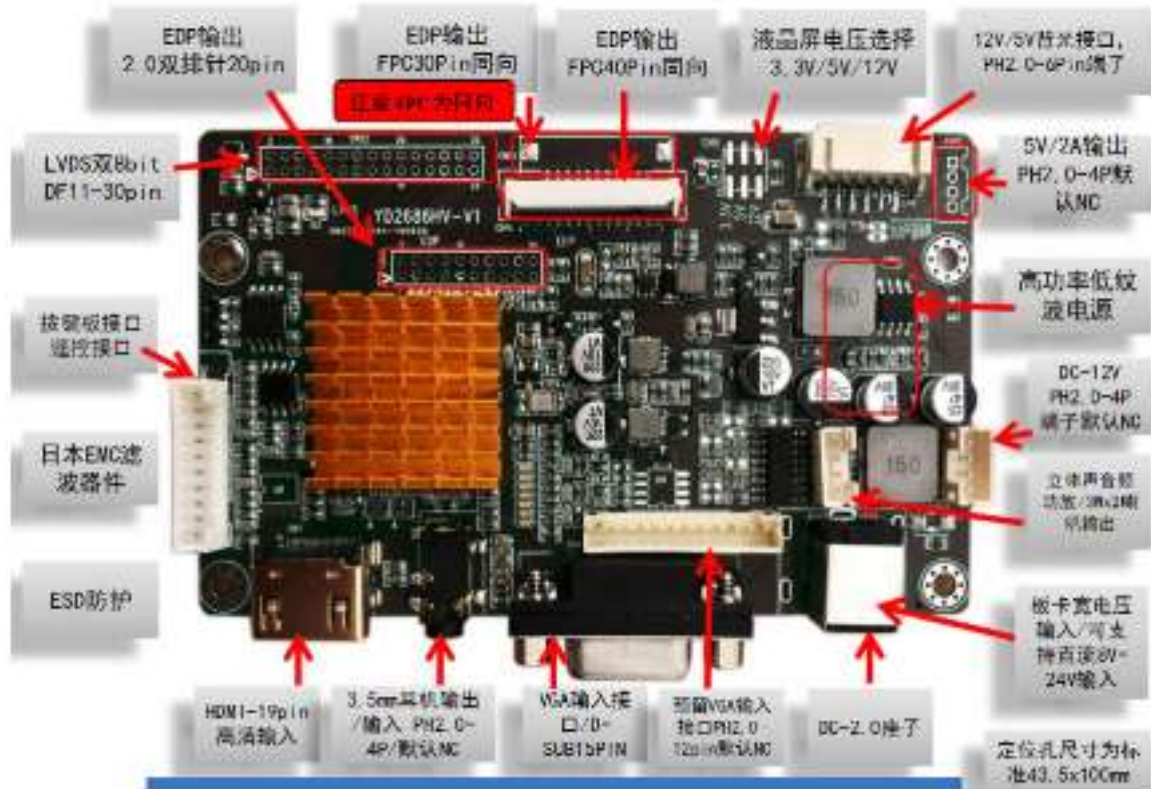



高度尺寸:

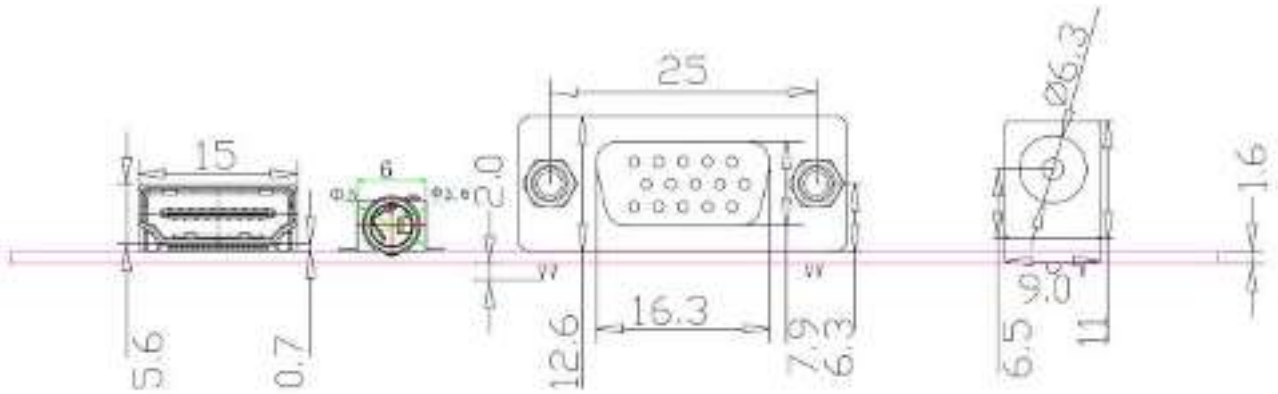

## 4.2 接口定义

- 标识: CN16
- 用途: EDP 信号输出
- 类型: FFC0.5mm-40pin, 翻盖插座
- 接插件:
- 针脚定义

引脚	符号	说明	引脚	符号	说明
1	NC	无功能	2	GND	地
3	eDP3P/3+	eDP LANE 3+ Signal数据	4	eDP3N/3-	eDP LANE 3- Signal数据
5	GND	地	6	eDP2P/2+	eDP LANE 2+ Signal数据
7	eDP2N/2-	eDP LANE 2- Signal数据	8	GND	地
9	eDP1P/1+	eDP LANE 1+ Signal数据	10	eDP1N/1-	eDP LANE 1- Signal数据
11	GND	地	12	Edp0P/0+	eDP LANE 0+ Signal数据
13	eDP0N/0-	eDP LANE 0- Signal数据	14	GND	地
15	AUX_P/+	Edp AUX_P + Signal数据	16	AUX_N/-	Edp AUX_N - Signal数据
17	GND	地	18	VCC-Panel	液晶屏 EDP 供电
19	VCC-Panel	液晶屏 EDP 供电	20	VCC-Panel	液晶屏 EDP 供电
21	VCC-Panel	液晶屏 EDP 供电	22	NC	无功能
23	GND	地	24	GND	地
25	GND	地	26	GND	地
27	EDP_HPD	EDP_Hot plug Detect	28	BK_GND	液晶屏背光供电负极
29	BK_GND	液晶屏背光供电负极	30	BK_GND	液晶屏背光供电负极
31	BK_GND	液晶屏背光供电负极	32	BK_EN	液晶屏背光开关
33	BK_PWM	液晶屏背光 PWM 亮度调节	34	NC	无功能
35	NC	无功能	36	BK_VCC	液晶屏背光供电正极
37	BK_VCC	液晶屏背光供电正极	38	BK_VCC	液晶屏背光供电正极
39	BK_VCC	液晶屏背光供电正极	40	NC	无功能



- 标识: CN9 (默认 NC)
- 用途: VGA 信号输入替代型接插件
- 类型: PH2.0mm-12PIN,2.0Pitch, 单排, 180°, 插座, 白色
- 接插件: (CVILUX)
- 针脚定义



引脚	符号	说 明	引脚	符号	说 明
1	VGA_SCL	DDC串行时钟	2	VGA_SDA	DDC串行数据
3	AGND	模拟地	4	BLU	模拟蓝色信号
5	AGND	模拟地	6	GRN	模拟绿色信号
7	AGND	模拟地	8	RED	模拟红色信号
9	GND	数字地	10	HSYNCIN	水平同步输入
11	VSYNCIN	垂直同步输入	12	GND	数字地

- 标识: CN1 (默认 NC)
- 用途: 12V 直流电源输入 (默认 NC)
- 类型: 4P, 2.0Pitch, 单排, 180°, 插座 (JST/CVILUX), 白色
- 接插件: PH2.0mm-4PIN直插
- 针脚定义



引脚	符号	说 明	引脚	符号	说 明
1	+12V	+12V 直流电源输入 (±10%)	2	+12V	+12V 直流电源输入 (±10%)
3	GND	地	4	GND	地



## 5. RELIABILITY TEST CONDITIONS

No	Test Item	Test Condition	STANDARD
1	High Temperature Storage	+60°C / 48Hours	1. Functional test is OK. Missing Segment, short, unclear segment, on-display, display abnormally and liquid crystal leak are un-allowed. 2. No low temperature bubbles, end seal loose and fall, frame rainbow.
2	Low Temperature Storage	-20°C / 48Hours	
3	High Temperature Operating	+50°C / 48Hours	
4	Low Temperature Operating	0°C / 48Hours	
5	Thermal and cold shock	0°C↔+50°C x 10cycles (30min) (5min) (30min)	
6	Operate at High Temperature and Humidity	50°C x 90%RH / 24H	
7	Vibration Test	Frequency: 10Hz~55Hz~10Hz Amplitude:1.5mm, 2 hours for each direction of X, Y, Z	1. Function test is OK. 2. No glass crack, chipped glass, end seal loose and fall, epoxy frame crack and so on. 3. No structure loose and fall.
8	Dropping test	Drop to the ground from 0.6m height, 1 corner, 3 edges, 6 surfaces.	
9	ESD test	Contact: ±6KV Air: ±10KV 150PF/330Ω,5Points/pa nel,5times	The test results shall be subject to the whole machine test.

### NOTE:

1. The reliability items will be fully performed in new sample qualification,
2. The reliability status will be tested as monitor during mass production. Individual reliability test shall be performed by lot , Moreover, the individual reliability item shall be decided according to reliability plan.
3. All samples are inspected after keeping in the room with normal temperature and humidity for 2 hours or above.
4. Vibration test: It is not necessary to test for those products without assembly frame , backlight , PCB and so on.
5. Dropping test : It is necessary for affirming new package.
6. For the high temperature and high humidity test, pure water of over 10 MΩ.cm should be used.
7. Each test item applies for test LCM only once .Then tested LCM cannot be used again in any other test item.
8. The quantity of LCM examination for each test item is 5pcs to 10pcs.



## 6. INSPECTION STANDARDS

### 6.1 AQL Sampling inspection standard

使用 GB/T 2828-2003 一般 II 水平, 采用正常检查一次抽样方式; 具体抽检方式参照《成品检验管理程序》、《抽样管理规范》

缺陷区分	AQL 允收水准
严重缺陷	0 收 1 退
重缺	0.4
轻缺	1.0

### 6.2 Inspect the condition

6.2.1 在 20—40W 日光灯的照明条件下, 样品离检查者眼睛约 30cm 处进行检查。检验方向以垂直线前后左右 45° (以时钟 3 点、6 点、9 点、12 点)

6.2.2 检验者视力需达到标准视力 1.0 以上。

6.2.3 检验者需戴静电手环、两手八个手指套。

6.2.4 外观检验者以目视检查或以菲林对比卡比对。

6.2.5 电性测试使用电测测架, 主板, 电源线及单片机。

6.2.6 若标准与规格书不符时, 以产品发行之规格书特殊检验规格、工程变更为准

6.2.7 辉色度检测请参照样品, 检测方法依照辉色度检验标准。

6.2.8 电测检验环境: 照度为 200LUX 以下, 外观检验环境: 照度为 600LUX-1000LUX, 检验时间: 1 秒-3 秒。

6.2.9 检验工具: 电测测架, 主板, 电源线及单片机, 菲林对比卡, 游标卡尺, 放大镜, 实体显微镜 (必要时) 等等。

### 6.3 Judgment criterion

小尺寸点、线判定标准: (6.2 寸以内)

1	点状缺陷 (磨伤、异物、针孔、凹痕、缺膜、气泡、白点、彩点、脏点)		判定 (A/B/C 区)	$D \leq 0.10$ , 忽略不计, 但密集型不允许	MI	OK
				$0.1 < D \leq 0.15$ , $ds \geq 10$		$N \leq 2$
				$0.15 < D \leq 0.2$ , $ds \geq 10$		$N \leq 1$
				LCD 亮点: $0.15 < D$		$N \leq 1$
				$D > 0.2$		NG
			判定 (D 区)	同背面丝印油墨区杂质判定标准		
			注: 1) D 区的点状缺陷需在不影响 CTP 功能、客户组装及整机的外观的情况下, 判定 OK		MI	
2	线状缺陷 (磨伤、无感划伤、毛屑、纤维等)		判定 (A/B/C 区)	$W \leq 0.03mm$ , $L \leq 3mm$ , $ds \geq 10$	MI	$N \leq 2$
				$0.03mm < W \leq 0.05mm$ , $L \leq 3mm$ , $ds \geq 10$		$N \leq 1$
				$W > 0.05mm$ 或 $L > 3mm$		NG





## 中尺寸点、线判定标准：（6.2~8寸以内）

1	点状缺陷 (磨伤、异物、针孔、凹痕、缺膜、气泡、白点、彩点、脏点)		判定(A/B/C区)	$D \leq 0.10$ , 忽略不计, 但密集型不允许 $0.15 < D \leq 0.25$ , $ds \geq 10$ $0.25 < D \leq 3$ , $ds \geq 10$ LCD亮点: $0.2 < D$ $D > 0.3$	MI	OK
			判定(D区)	同背面丝印油墨区杂质判定标准		N $\leq$ 2 N $\leq$ 1 N $\leq$ 1 NG
			注: 1) D区的点状缺陷需在不影响CTP功能、客户组装及整机的外观的情况下, 判定OK		MI	
2	线状缺陷 (磨伤、无感划伤、毛屑、纤维等)		判定(A/B/C区)	$W \leq 0.03mm$ , $L \leq 3mm$ , $ds \geq 10$ $0.03mm < W \leq 0.05mm$ , $L \leq 3mm$ , $ds \geq 10$	MI	N $\leq$ 2
				$W > 0.05mm$ 或 $L > 3mm$		N $\leq$ 1
						NG

## 大尺寸点、线判定标准：（8.1~13.3寸以内）

1	点状缺陷 (磨伤、异物、针孔、凹痕、缺膜、气泡、白点、彩点、脏点)		判定(A/B/C区)	$D \leq 0.1$ , 忽略不计, 但密集型不允许 $0.15 < D \leq 0.3$ , $ds \geq 10$ $0.3 < D \leq 0.35$ , $ds \geq 10$ LCD亮点: $0.25 < D$ $D > 0.35$	MI	OK
			判定(D区)	同背面丝印油墨区杂质判定标准		N $\leq$ 2 N $\leq$ 1 N $\leq$ 1 NG
			注: 1) D区的点状缺陷需在不影响CTP功能、客户组装及整机的外观的情况下, 判定OK		MI	
2	线状缺陷 (磨伤、无感划伤、毛屑、纤维等)		判定(A/B/C区)	$W \leq 0.05mm$ , $L \leq 5mm$ , $ds \geq 10$ $0.05mm < W \leq 0.07mm$ , $L \leq 5mm$ , $ds \geq 10$	MI	N $\leq$ 2
				$W > 0.07mm$ 或 $L > 5mm$		N $\leq$ 1
						NG



## 7. PACKAGE DRAWING

