



SPECIFICATION FOR TFT LCD MODULE

CUSTOMER : _____

CUSTOMER MODULE : _____

HL MODEL : HG035SV003

Preliminary Specification

Final Specification

Customer Confirmation column:

Approved by : _____ Dept. : _____ Data : _____

Please return one of the copies of the specification with your signature to us within two weeks after you receive this document. If it is not returned, we will assume that you agree to the entire contents of this specification document.

Designed by	Checked by	Approved by



修订记录 (RECORDS OF REVISION)

Version	Date	Page	Description	Changed By
V00	2022-09-05	-	First issue	Jobin



目录 (Contents)

一	说明 (Description)	4
二	基本参数 (Basic parameters)	4
三	模块结构 (MODULE STRUCTURE)	5
四	引脚说明 (Pin Description)	6
五	极限参数 (ABSOLUTE MAXIMUM RATINGS)	7
六	背光电气特性 (BACKLIGHT CHARACTERISTICS)	7
七	液晶电气特性 (Electrical characteristics)	8
八	光学特性 (OPTICAL CHARACTERISTICS)	9
九	模块驱动图 (Module driver diagram)	12
十	时序特性 (TIMING CHARACTERISTICS)	13
十一	LCM 质量标准(LCM Quality Criteria)	15
十二	包装方法(Packing method)	22



一. 说明 (Description)

HG035SV003 是一种采用非晶态薄膜晶体管作为开关器件的透射式彩色主矩阵液晶显示器。本产品由 tft 液晶面板、驱动器 IC、RTP、FPC 和 LED 背光装置组成。主动显示面积为 3.54 英寸，对角线测量，本机分辨率为 800*RGB*640。下表列出了本产品的特点。

(HG035SV003 is a transmissive type color active matrix liquid crystal display(LCD) which uses amorphous thin film transistor(TFT) as switching devices. This product is composed of a TFT LCD panel, a drive IC, a RTP,a FPC and a LED-backlight unit. The active display area is 3.54" inches diagonally measured and the native resolution is 800*RGB*640.Features of this product are listed in the following table.)

二. 基本参数 (Basic parameters)

项目 (ITEM)	标准值 (Standard value)	单位 (UNIT)
LCD 类型 (LCD Type)	TFT Negative Transmissive	---
Driver element	a-Si TFT Active matrix	
点阵 (Number of Dots)	800*(RGB)*640	Dots
Pixel Arrangement	RGB Vertical Stripe	
点距 (Dot Pitch (W*H))	0.1125*0.1125	mm
模块尺寸 (ModuleSize (W*H*T))	97.6*83.8*4.0	mm
显示区 (Active Area)	90.0*72.0	mm
视角 (ViewingDirection)	ALL' clock	
驱动 IC (Driver IC)	FL5893DA	
输入电压 (Input voltage)	3.3	V
重量 (Approx. Weight)	TBD	g
背光 (Back Light)	6 串 2 并 12White LED 18V180mA	
模组亮度 (Modulebrightness)	800 cd/m	cd/m
接口方式 (Interface Mode)	3SPI+24RGB	



三. 模块结构 (MODULE STRUCTURE)

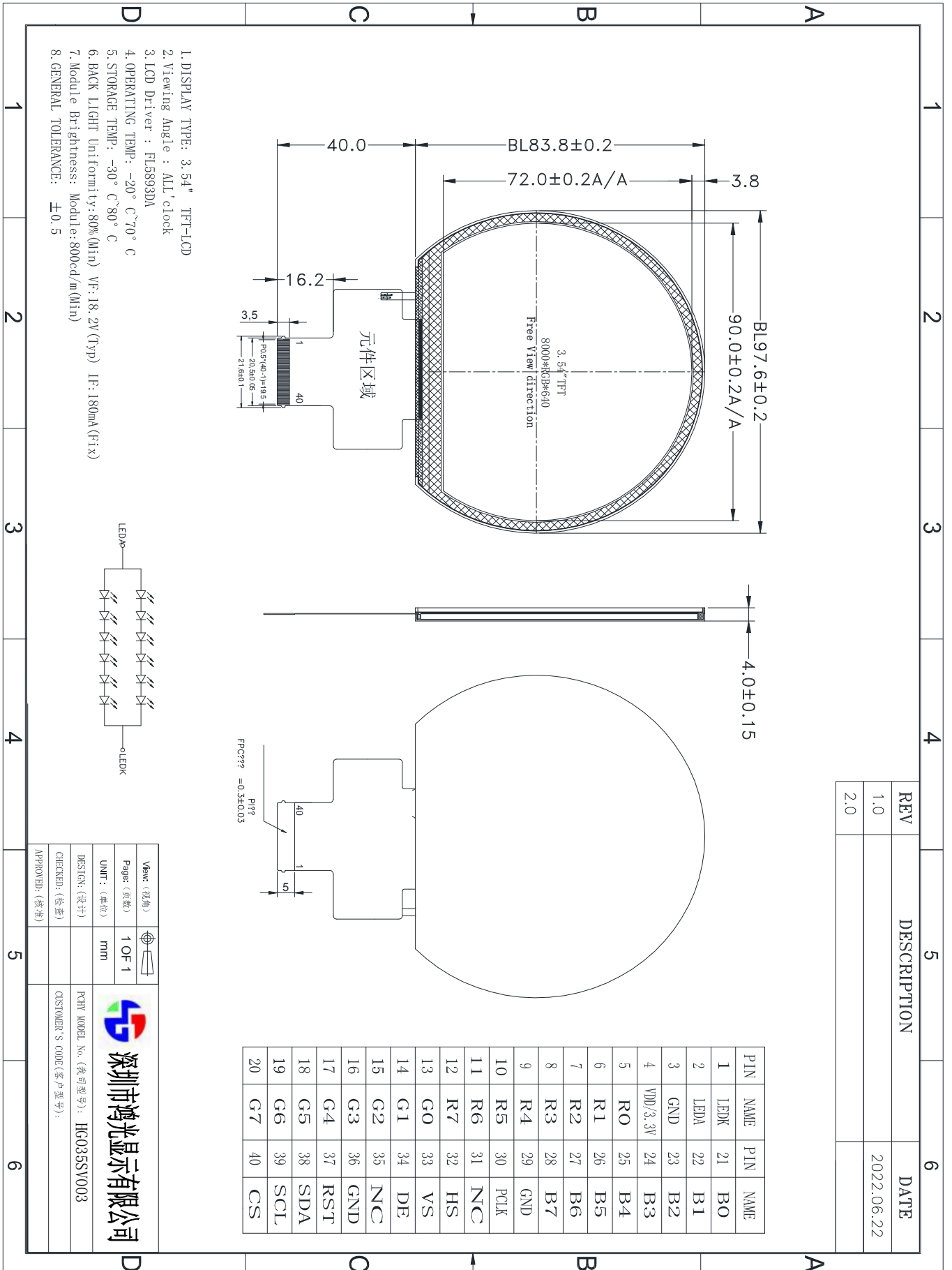



四. 引脚说明 (Pin Description)

Input Signal and Power(40 Pins FPC PAD)

Pin NO.	Symbol	Description	Remark
1	LEDK	P	LED Power supply -
2	LEDA	P	LED Power supply +
3	GND	P	System ground.
4	VDD	P	Power supply, 3.0~3.6V
5~12	R0~R7	I/O	RED Datas
13~20	G0~G7	I/O	GREEN Datas
21~28	B0~B7	I/O	BLUE Datas
29	GND	P	System ground.
30	CLK	I	Dot clock signal
31	NC	I	NC
32	HS	I	Horizontal synchronizing signal.
33	VS	I	Vertical synchronizing signal.
34	DE	I	Data ENABLE signal
35	N.C	-	No Connection.
36	GND	P	System ground.
37	RESET	I	The external reset input
38	SDA	I	Serial data input/output bidirectional pin for SPI Interface.
39	SCL	I	Serial clock input for SPI interface.
40	CS	I	A chip select signal



五. 极限参数 (ABSOLUTE MAXIMUM RATINGS)

项目/参数 (Item/Parameter)	符号 (Symbol)	最小 (Min)	最大 (Max)	单位 (Unit)
逻辑电压/Supply voltage for logic	V_{DD}	-	3.5	V
输入电压/Input voltage for logic	V_{IN}	-	$V_{DD} + 0.3$	V
工作温度/ Operating temperature	T_{ST}	-20	+70	°C
储存温度/Storage temperature	T_{ST}	-30	+85	°C
湿度/Humidity	RH	-	90%Max60° C	RH

注：极限条件仅指产品能短暂承受的范围，不可超过 120 小时。如果产品长间在极限条件，将有损产品使用寿命。

Note: Absolute maximum ratings means the product can withstand short-term, NOT more than 120 hours.

If the product is a long time to withstand these conditions, the life time would be shorter.

六. 背光电气特性 BACKLIGHT CHARACTERISTICS

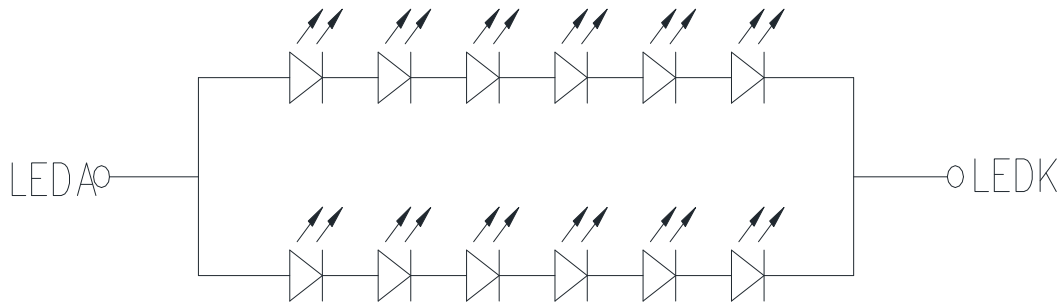

项目/Item	Symbol	MIN	TYP	MAX	UNIT	Test Condition	Note
电压/Forward voltage	V_f	-	18.2	-	V	$I_f = 180 \text{ mA}$	-
电流/Supply Current	I_f	-	180	-	mA	-	-
Power dissipation	P_d	-	140	-	mW	-	-
Uniformity for LCM	-	80	-	-	%	$I_f = 180 \text{ mA}$	-

Using condition: constant current driving method $I_f = 180 \text{ mA} (+/-10\%)$

使用条件：恒流的驱动方式是 $I_f = 180 \text{ mA} (+/-10\%)$



七. 电气特性 (Electrical characteristics)

Properties		Sym.	Min	Typ.	Max	Unit	Note
Power for Circuit Driving		V _{cc}	2.7	3.3	3.5	V	Note
Interface Voltage		IOV _{cc}	1.65	1.8	3.3	V	Note
Power for Circuit Logic		V _t	2.6	2.8	3.0	V	Note
BLU Driving Logic		V _{bat}	-	3.3	-	V	
Logic Input Voltage	Low Voltage	V _{IL}	-0.3	-	0.2V _{cc}	V	
	High Voltage	V _{IH}	0.8xV _{cc}	-	V _{cc}	V	
Logic Output Voltage	Low Voltage	V _{OL}	0	-	0.2V _{cc}	V	
	High Voltage	V _{OH}	0.8V _{cc}	-	-	V	
Power Consumption	White	P _w	T. B. D	T. B. D	T. B. D	mW	
	Black	P _b	T. B. D	T. B. D	T. B. D	mW	
	Vertical Stripe	P _v	T. B. D	T. B. D	T. B. D	mW	

Note:

The recommended operating conditions refer to a range in which operation of this product is guaranteed. Should this range is exceeded, the operation cannot be guaranteed even if the values may be without the absolute maximum ratings.

Accordingly, please make sure that the module is used within this range. And these current values are measured under the condition that all devices are stopped, each component is stable and logic signal is input.



八. 光学特性 (OPTICAL CHARACTERISTICS)

Spec	参数/Parameter	符号 Sym.	值/Values			Unit	Note	
			Min.	Typ.	Max.			
With Back light LED ON	*1) 对比度 /ContrastRatio	C/R	1000	1200	-		Note	
	*2) 透过率 /Transmittance	T%		2.62		%	FIG. 1	
	*1) 响应 /Response Time	Tr+ Tf		25		Mses	FIG. 4	
	*1) 视角/ Viewing Angle	θ_l			85	-	Degree	FIG. 5
		θ_r			85	-		
		θ_u			85	-		
		θ_d			85	-		
	*3) 颜色坐标/ CIE Color Coordinate	Wx			0.293			
		Wy			0.320			
		Rx			0.651			
		Ry			0.317			
		Gx			0.261			
		Gy			0.570			
Bx				0.138				
By				0.083				
色域 Color Gamut	S (%)		-	70	-	%	FIG. 3	



Note (1) Definition of Viewing

Angle:

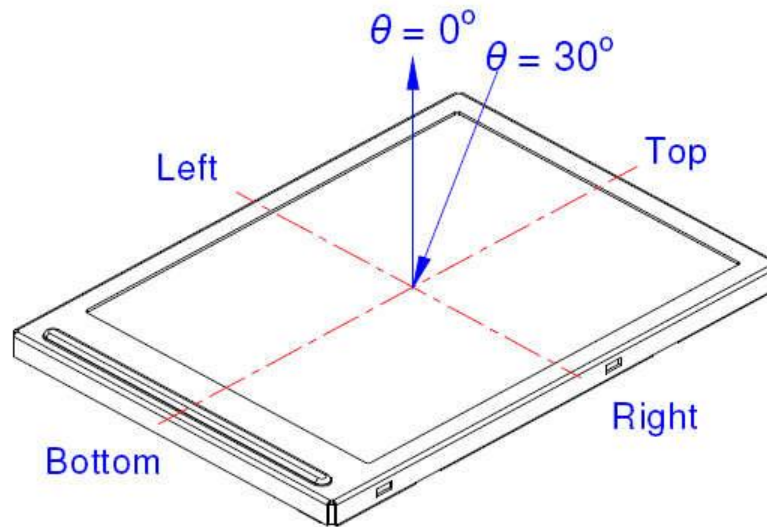

Note 2: Definition of contrast ratio CR:

$$\text{Contrast ratio (CR)} = \frac{\text{Photo detector output when LCD is at "White" state}}{\text{Photo detector output when LCD is at "Black"}}$$

Note 3: Definition of response time (T_R , T_F)

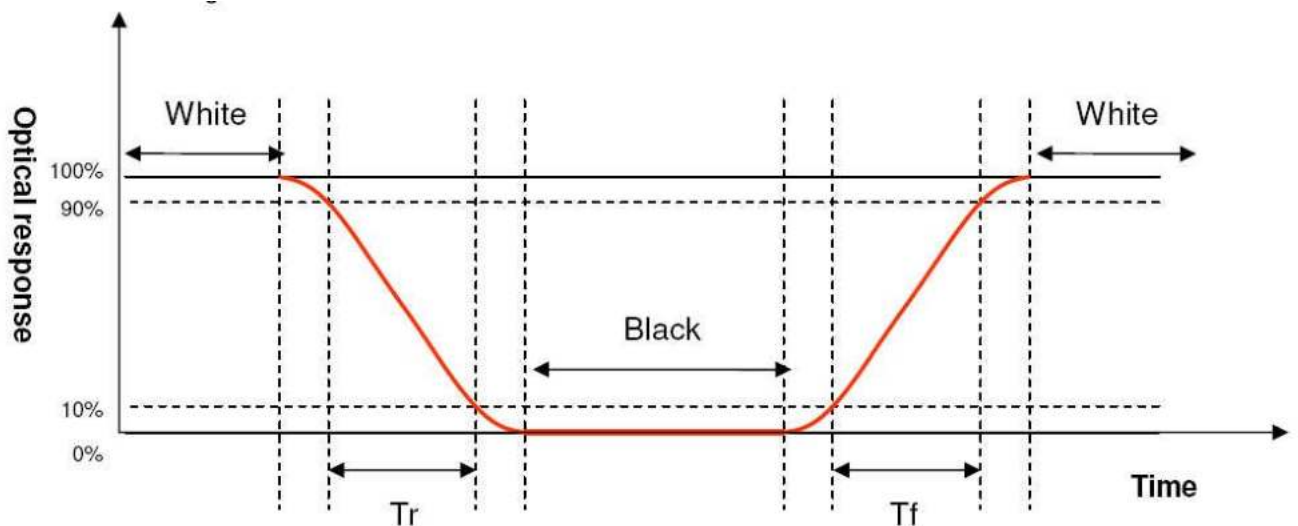



The brightness test equipment setup

20mA Field=2° (As measuring "black" image, field=2° is the best testing condition)

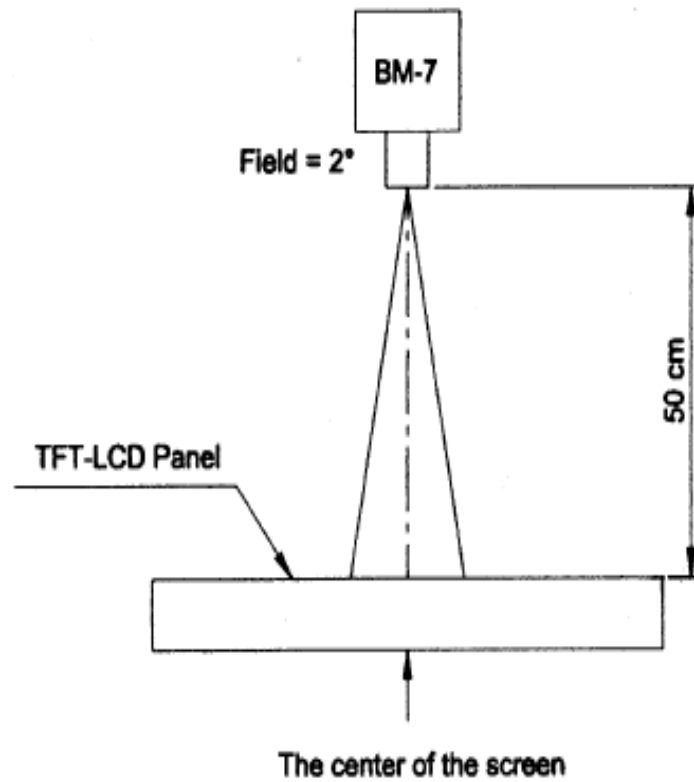

Note 4 :

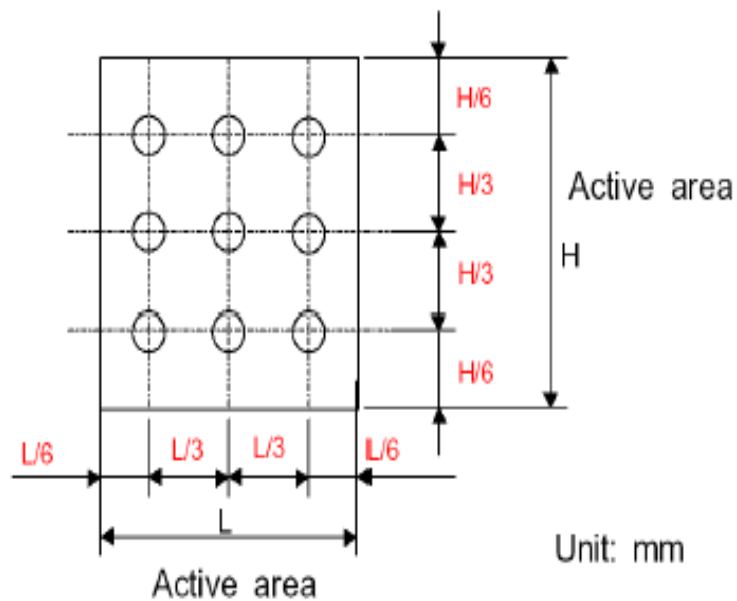



九. 模块驱动图 (Module driver diagram)

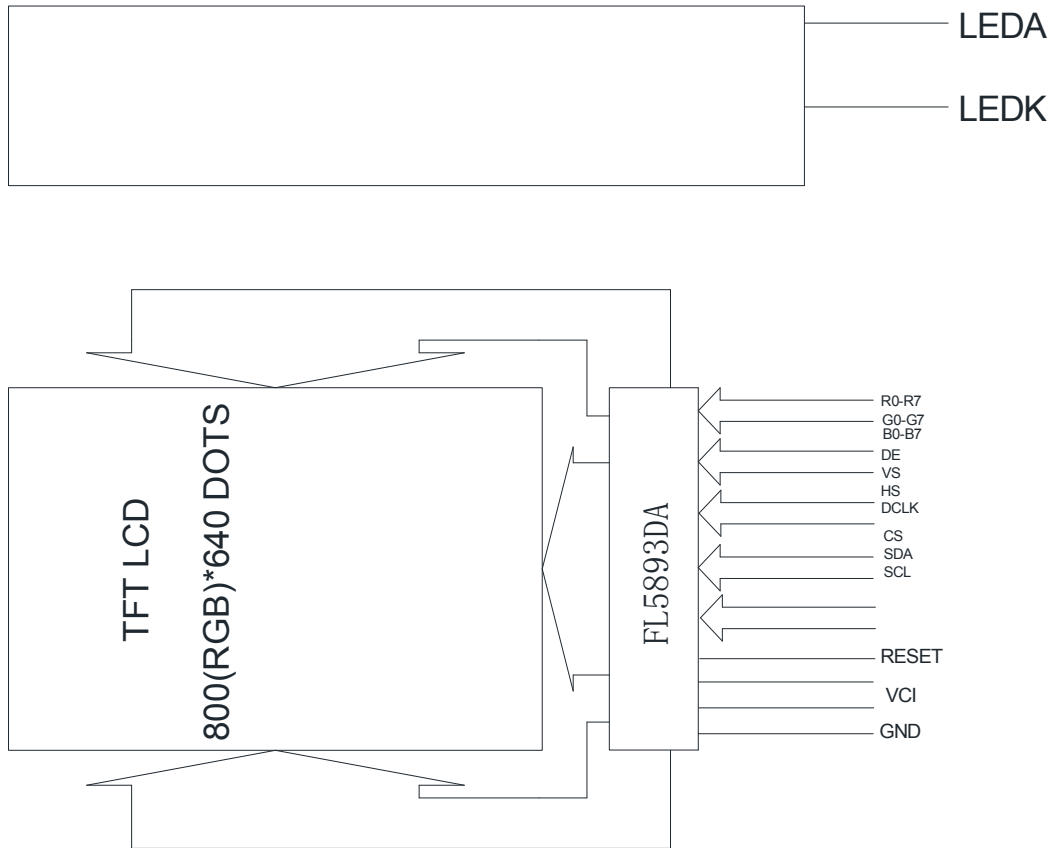



十. 时序特性 (TIMING CHARACTERISTICS)

10.1 输入时钟和数据定时波形

5.1.2 4-Wire Serial Peripheral Interface

This chip supports serial peripheral interface (SPI) to set internal registers. Under write operation, R/W bit equals to "0," and the external controller sends the address and data to the chip by SPI_SDAI. Under read operation, R/W bit equals to "1," and the external controller sends the address to the chip by SPI_SDAI. Then the chip will return the data value by SPI_SDAO. The returned data should be latched at the rising edge of SPI_SCL from the external controller. This chip also supports the burst R/W mode to reduce the programming time. The external controller can just send the R/W and address once, when the chip is in the burst mode. Then the chip will increase address automatically to read/write internal registers.

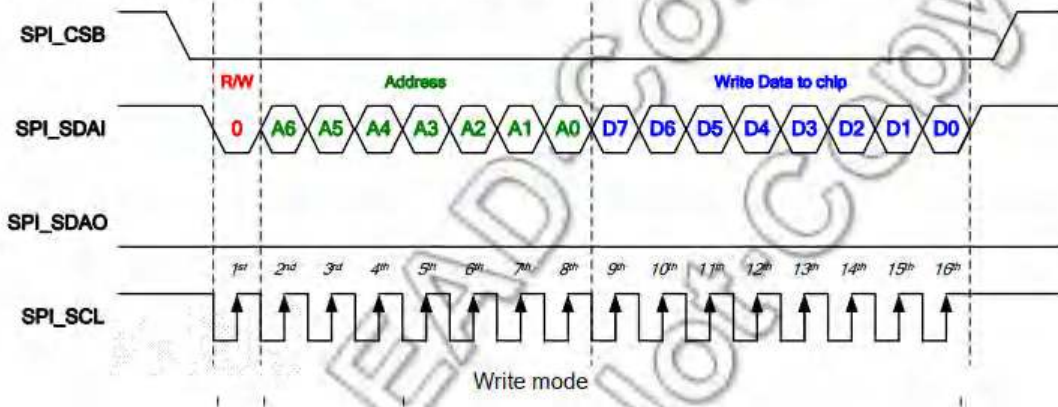

5.2.2.2 SYNC Mode

Parallel RGB

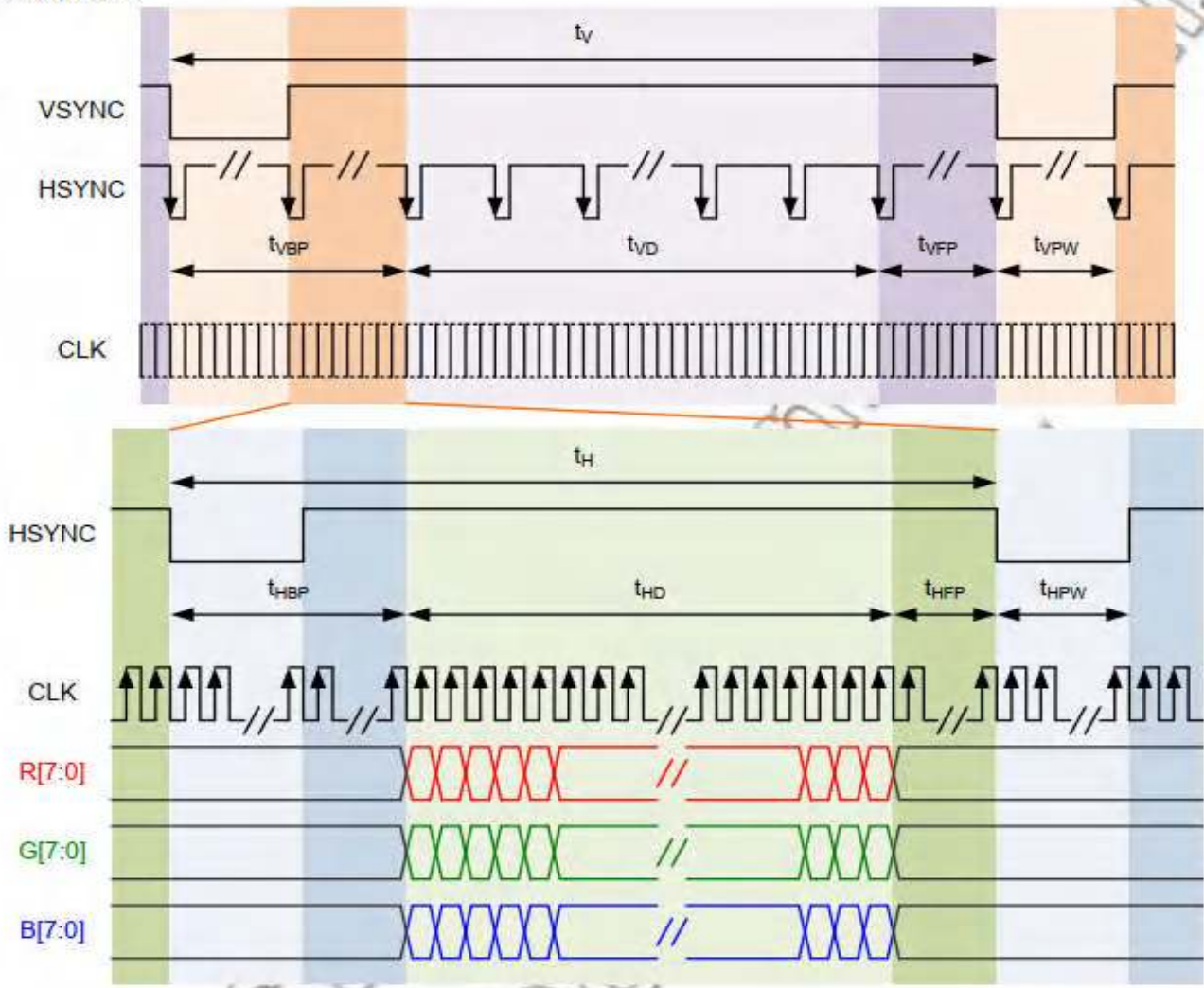



10.2. Time table

Parameter	Symbol	Spec			Unit
		Min.	Typ.	Max.	
水平/Horizontal Display Area	thd		800	-	DCLK
频率/DCLK frequency	Pclk				MHz
HS 脉冲宽度/HS pulse width	Thw		10		DCLK
后廊/HS Back porch	Thbp		10		DCLK
前廊/HS Front Porch	Thfp		20		DCLK
垂直/Vertical Display Area	Tvd		640	-	-
Vertical blanking period	VBK				
VS 脉冲宽度/VS pulse width	TVW		10		TH
VS 后廊/VS Back Porch	Tvbp		10		TH
VS 前廊/VS Front Porch	Tvfp		20		TH

Timing Characteristics

Please refer to FL5893DA DATASHEET.



十一. LCM 质量标准(LCM Quality Criteria)

11.1 外观和功能检查标准(VISUAL & FUNCTION INSPECTION STANDARD)

11.1.1 检验条件(Inspection conditions)

建议在以下条件下进行检查。

Inspection performed under the following conditions is recommended.

温度: $25 \pm 5^{\circ}\text{C}$ (Temperature : $25 \pm 5^{\circ}\text{C}$)

湿度: $65\% \pm 10\% \text{RH}$ (Humidity : $65\% \pm 10\% \text{RH}$)

视角: 正常视角。(Viewing Angle : Normal viewing Angle.)

照明: 单盏荧光灯 (300 至 700Lux) (Illumination: Single fluorescent lamp (300 to 700Lux))

查看距离: 30-50cm (Viewing distance: 30-50cm)

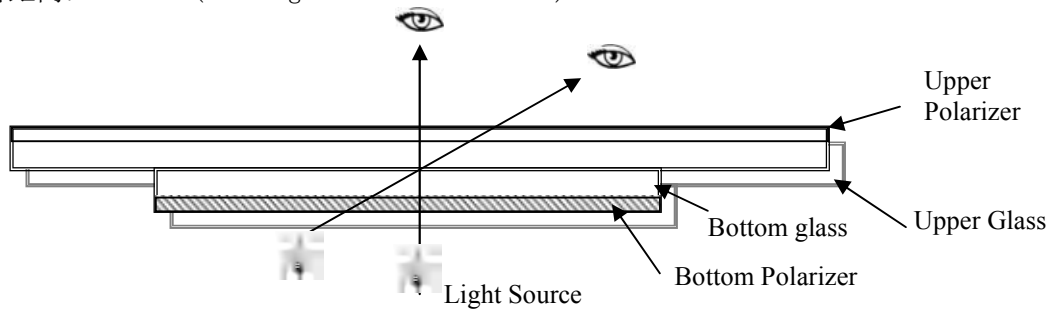

11.1.2 定义(Definition)

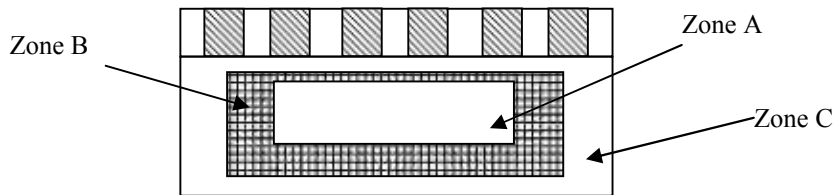

A 区: 有效可视区域 (可看到字符或数字)

Zone A : Effective Viewing Area (Character or Digit can be seen)

B 区: 除 A 区外的观察区

Zone B : Viewing Area except Zone A

C 区: 外部 (A 区+B 区), 客户组装后看不到。)

Zone C : Outside (Zone A+Zone B) which can not be seen after assembly by customer .)

注: 作为一般来说, C 区的视觉缺陷在客户装配后不影响产品功能或外观时可以忽略不计。

Note: As a general rule, visual defects in Zone C can be ignored when it doesn't effect product function or appearance after assembly by customer.

11.1.3 Sampling Plan

按 GB/T 2828-2003; , 常规检验, II 级

AQL: According to GB/T 2828-2003 ; , normal inspection, Class II

AQL:

重大缺陷/Major defect	轻微缺陷/Minor defect
0.65	1.5

LCD: 液晶显示器, TP: 触摸面板, LCM: 液晶模块

LCD: Liquid Crystal Display, TP: Touch Panel, LCM: Liquid Crystal Module



No	Items to be inspected	Criteria	Classification of defects
1	功能性缺陷 /Functional defects	1) 无显示、打开或缺线 (No display, Open or miss line) 2) 显示异常, 短路 (Display abnormally, Short) 3) 背光无照明, 照明异常。 (Backlight no lighting, abnormal lighting.) 4) TP 无功能 (TP no function)	重大缺陷 Major defect
2	缺 Missing	缺少组件 (Missing component)	
3	外形尺寸/ Outline dimension	外形尺寸不允许超出图纸 (Overall outline dimension beyond the drawing is not allowed)	
4	色调/Color tone	颜色不均匀, 参考有限样本 Color unevenness, refer to limited sample	轻微 Minor
5	焊接外观/Soldering appearance	焊接良好, 不允许剥落。 Good soldering , Peeling off is not allowed.	
6	LCD/Polarizer/TP	黑点/白点/线、划痕、裂纹等/ Black/White spot/line, scratch, crack, etc.	

11.1.4 标准 Criteria (Visual)

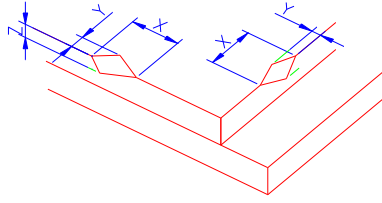
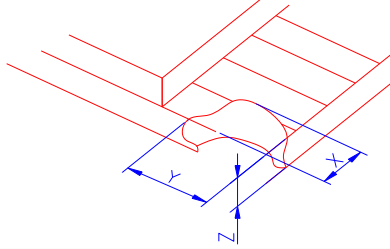
Number	项目/Items	Criteria (mm)						
1.0 LCD Crack/Broken	液晶显示器的边缘坏 (1) The edge of LCD broken	 <table border="1" data-bbox="853 1214 1396 1370"> <thead> <tr> <th>X</th> <th>Y</th> <th>Z</th> </tr> </thead> <tbody> <tr> <td>≤3.0mm</td> <td><Inner border line of the seal</td> <td>≤T</td> </tr> </tbody> </table>	X	Y	Z	≤3.0mm	<Inner border line of the seal	≤T
X	Y	Z						
≤3.0mm	<Inner border line of the seal	≤T						
NOTE: X: Length Y: Width Z: Height L: Length of ITO, T: Height of LCD	LCD 角断开 (2) LCD corner broken	 <table border="1" data-bbox="912 1662 1337 1736"> <thead> <tr> <th>X</th> <th>Y</th> <th>Z</th> </tr> </thead> <tbody> <tr> <td>≤3.0mm</td> <td>≤L</td> <td>≤T</td> </tr> </tbody> </table>	X	Y	Z	≤3.0mm	≤L	≤T
X	Y	Z						
≤3.0mm	≤L	≤T						



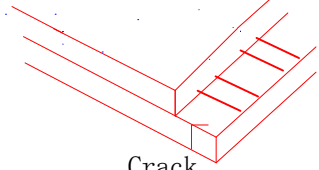

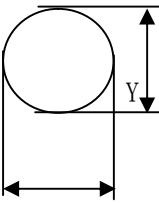
	液晶显示器裂纹 (3) LCD crack	 <p>Crack Not allowed</p>
--	--------------------------	-----------------------------------------------------------------------------------------------------------------

Number	Items	Criteria (mm)																							
2.0	斑点缺陷 Spot defect  <p style="text-align: center;">$\Phi = (X+Y)/2$</p>	①光点 (LCD/TP/偏振器黑点/白点、光点、针孔、凹痕、污点) light dot (LCD/TP/Polarizer black/white spot, light dot, pinhole, dent, stain)																							
		<table border="1" style="width: 100%;"> <thead> <tr> <th rowspan="2">Zone Size (mm)</th> <th colspan="3">可接受数量 (Acceptable Qty)</th> </tr> <tr> <th>A</th> <th>B</th> <th>C</th> </tr> </thead> <tbody> <tr> <td>$\Phi \leq 0.10$</td> <td colspan="3">忽略 (Ignore)</td> </tr> <tr> <td>$0.10 < \Phi \leq 0.15$</td> <td colspan="3">3 (distance $\geq 10\text{mm}$)</td> </tr> <tr> <td>$0.15 < \Phi \leq 0.2$</td> <td colspan="3">1</td> </tr> <tr> <td>$0.2 < \Phi$</td> <td colspan="3">0</td> </tr> </tbody> </table>	Zone Size (mm)	可接受数量 (Acceptable Qty)			A	B	C	$\Phi \leq 0.10$	忽略 (Ignore)			$0.10 < \Phi \leq 0.15$	3 (distance $\geq 10\text{mm}$)			$0.15 < \Phi \leq 0.2$	1			$0.2 < \Phi$	0		
		Zone Size (mm)		可接受数量 (Acceptable Qty)																					
			A	B	C																				
		$\Phi \leq 0.10$	忽略 (Ignore)																						
		$0.10 < \Phi \leq 0.15$	3 (distance $\geq 10\text{mm}$)																						
		$0.15 < \Phi \leq 0.2$	1																						
		$0.2 < \Phi$	0																						
		暗点 (LCD/TP/偏振器暗点、漏光、暗点) ②Dim spot (LCD/TP/Polarizer dim dot, light leakage, dark spot)																							
		<table border="1" style="width: 100%;"> <thead> <tr> <th rowspan="2">Zone Size (mm)</th> <th colspan="3">可接受数量 (Acceptable Qty)</th> </tr> <tr> <th>A</th> <th>B</th> <th>C</th> </tr> </thead> <tbody> <tr> <td>$\Phi \leq 0.1$</td> <td colspan="3">忽略 (Ignore)</td> </tr> <tr> <td>$0.1 < \Phi \leq 0.2$</td> <td colspan="3">2 (distance $\geq 10\text{mm}$)</td> </tr> <tr> <td>$0.2 < \Phi \leq 0.3$</td> <td colspan="3">1</td> </tr> <tr> <td>$\Phi > 0.3$</td> <td colspan="3">0</td> </tr> </tbody> </table>	Zone Size (mm)	可接受数量 (Acceptable Qty)			A	B	C	$\Phi \leq 0.1$	忽略 (Ignore)			$0.1 < \Phi \leq 0.2$	2 (distance $\geq 10\text{mm}$)			$0.2 < \Phi \leq 0.3$	1			$\Phi > 0.3$	0		
		Zone Size (mm)		可接受数量 (Acceptable Qty)																					
			A	B	C																				
		$\Phi \leq 0.1$	忽略 (Ignore)																						
		$0.1 < \Phi \leq 0.2$	2 (distance $\geq 10\text{mm}$)																						
		$0.2 < \Phi \leq 0.3$	1																						
$\Phi > 0.3$	0																								
偏振器暗点 ③ Polarizer accidented spot																									
<table border="1" style="width: 100%;"> <thead> <tr> <th rowspan="2">Zone Size (mm)</th> <th colspan="3">可接受数量 (Acceptable Qty)</th> </tr> <tr> <th>A</th> <th>B</th> <th>C</th> </tr> </thead> <tbody> <tr> <td>$\Phi \leq 0.2$</td> <td colspan="3">忽略 (Ignore)</td> </tr> <tr> <td>$0.2 < \Phi \leq 0.5$</td> <td colspan="3">2 (distance $\geq 10\text{mm}$)</td> </tr> <tr> <td>$\Phi > 0.5$</td> <td colspan="3">0</td> </tr> </tbody> </table>	Zone Size (mm)	可接受数量 (Acceptable Qty)			A	B	C	$\Phi \leq 0.2$	忽略 (Ignore)			$0.2 < \Phi \leq 0.5$	2 (distance $\geq 10\text{mm}$)			$\Phi > 0.5$	0								
Zone Size (mm)		可接受数量 (Acceptable Qty)																							
	A	B	C																						
$\Phi \leq 0.2$	忽略 (Ignore)																								
$0.2 < \Phi \leq 0.5$	2 (distance $\geq 10\text{mm}$)																								
$\Phi > 0.5$	0																								



	线路缺陷 (LCD/TP /偏光镜 (黑 /白线、划 痕、污渍) Line defect (LCD/TP /Polarizer black/white line, scratch, stain)	<table border="1"> <thead> <tr> <th rowspan="2">Width(mm)</th> <th rowspan="2">Length(mm)</th> <th colspan="3">Acceptable Qty</th> </tr> <tr> <th>A</th> <th>B</th> <th>C</th> </tr> </thead> <tbody> <tr> <td>$\Phi \leq 0.03$</td> <td>Ignore</td> <td colspan="3">Ignore</td> </tr> <tr> <td>$0.03 < W \leq 0.05$</td> <td>$L \leq 3.0$</td> <td colspan="3">$N \leq 2$</td> </tr> <tr> <td>$0.05 < W \leq 0.08$</td> <td>$L \leq 2.0$</td> <td colspan="3">$N \leq 2$</td> </tr> <tr> <td>$0.08 < W$</td> <td colspan="4">Define as spot defect</td> </tr> </tbody> </table>				Width(mm)	Length(mm)	Acceptable Qty			A	B	C	$\Phi \leq 0.03$	Ignore	Ignore			$0.03 < W \leq 0.05$	$L \leq 3.0$	$N \leq 2$			$0.05 < W \leq 0.08$	$L \leq 2.0$	$N \leq 2$			$0.08 < W$	Define as spot defect			
Width(mm)	Length(mm)	Acceptable Qty																															
		A	B	C																													
$\Phi \leq 0.03$	Ignore	Ignore																															
$0.03 < W \leq 0.05$	$L \leq 3.0$	$N \leq 2$																															
$0.05 < W \leq 0.08$	$L \leq 2.0$	$N \leq 2$																															
$0.08 < W$	Define as spot defect																																
3.0	偏光泡 Polarizer Bubble	<table border="1"> <thead> <tr> <th rowspan="2">Zone Size (mm)</th> <th colspan="3">可接受数量 (Acceptable Qty)</th> </tr> <tr> <th>A</th> <th>B</th> <th>C</th> </tr> </thead> <tbody> <tr> <td>$\Phi \leq 0.2$</td> <td colspan="3">忽略 (Ignore)</td> </tr> <tr> <td>$0.2 < \Phi \leq 0.4$</td> <td colspan="3">2 (distance $\geq 10\text{mm}$)</td> </tr> <tr> <td>$0.4 < \Phi \leq 0.6$</td> <td colspan="3">1</td> </tr> <tr> <td>$0.6 < \Phi$</td> <td colspan="3">0</td> </tr> </tbody> </table>				Zone Size (mm)	可接受数量 (Acceptable Qty)			A	B	C	$\Phi \leq 0.2$	忽略 (Ignore)			$0.2 < \Phi \leq 0.4$	2 (distance $\geq 10\text{mm}$)			$0.4 < \Phi \leq 0.6$	1			$0.6 < \Phi$	0							
Zone Size (mm)	可接受数量 (Acceptable Qty)																																
	A	B	C																														
$\Phi \leq 0.2$	忽略 (Ignore)																																
$0.2 < \Phi \leq 0.4$	2 (distance $\geq 10\text{mm}$)																																
$0.4 < \Phi \leq 0.6$	1																																
$0.6 < \Phi$	0																																
4.0	SMT	按 IPC-A-610C II 级标准。功能缺陷和缺件为主要缺陷，其余为次要缺陷。 According to IPC-A-610C class II standard . Function defect and missing part are major defect , the others are minor defect.																															
		TP bubble/ accidented spot	<table border="1"> <thead> <tr> <th rowspan="2">Size Φ (mm)</th> <th colspan="3">可接受数量 (Acceptable Qty)</th> </tr> <tr> <th>A</th> <th>B</th> <th>C</th> </tr> </thead> <tbody> <tr> <td>$\Phi \leq 0.1$</td> <td colspan="3">忽略 (Ignore)</td> </tr> <tr> <td>$0.1 < \Phi \leq 0.2$</td> <td colspan="3">2</td> </tr> <tr> <td>$0.2 < \Phi \leq 0.3$</td> <td colspan="3">1</td> </tr> <tr> <td>$0.3 < \Phi$</td> <td colspan="3">0</td> </tr> </tbody> </table>			Size Φ (mm)	可接受数量 (Acceptable Qty)			A	B	C	$\Phi \leq 0.1$	忽略 (Ignore)			$0.1 < \Phi \leq 0.2$	2			$0.2 < \Phi \leq 0.3$	1			$0.3 < \Phi$	0							
Size Φ (mm)	可接受数量 (Acceptable Qty)																																
	A	B	C																														
$\Phi \leq 0.1$	忽略 (Ignore)																																
$0.1 < \Phi \leq 0.2$	2																																
$0.2 < \Phi \leq 0.3$	1																																
$0.3 < \Phi$	0																																
	Assembly deflection	背光边缘外 $\leq 0.15\text{mm}$ beyond the edge of backlight $\leq 0.15\text{mm}$																															

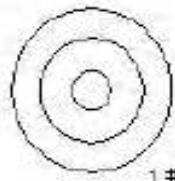
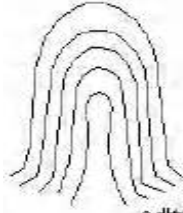

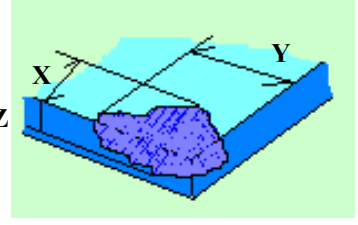
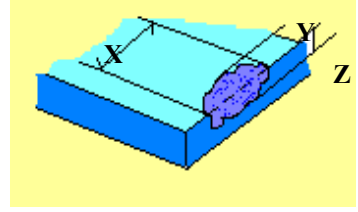
5.0	TP Related	<p>牛顿环 Newton Ring</p> <p>牛顿环面积 > 1/3 TP 面积 NG</p> <p>Newton Ring area > 1/3 TP area NG</p> <p>牛顿环面积 ≤ 1/3 TP 面积 OK</p> <p>Newton Ring area ≤ 1/3 TP area OK</p>	 <p>1 规律性</p>  <p>2 非规律性</p>  <p>似牛顿环</p>						
		<p>TP corner broken</p> <p>X: length Y: width Z: height</p> <table border="1" data-bbox="638 1041 1077 1187"> <tr> <td>X</td> <td>Y</td> <td>Z</td> </tr> <tr> <td>X ≤ 3.0mm</td> <td>Y ≤ 3.0mm</td> <td>Z < LCD thickness</td> </tr> </table> <p>* Circuitry broken is not allowed.</p>	X	Y	Z	X ≤ 3.0mm	Y ≤ 3.0mm	Z < LCD thickness	
		X	Y	Z					
X ≤ 3.0mm	Y ≤ 3.0mm	Z < LCD thickness							
<p>TP edge broken</p> <p>X: length Y: width Z: height</p> <table border="1" data-bbox="630 1288 1069 1422"> <tr> <td>X</td> <td>Y</td> <td>Z</td> </tr> <tr> <td>X ≤ 6.0mm</td> <td>Y ≤ 2.0mm</td> <td>Z < LCD thickness</td> </tr> </table> <p>* Circuitry broken is not allowed.</p>	X	Y	Z	X ≤ 6.0mm	Y ≤ 2.0mm	Z < LCD thickness			
X	Y	Z							
X ≤ 6.0mm	Y ≤ 2.0mm	Z < LCD thickness							

Criteria (functional items)

Number	Items	Criteria (mm)
1	No display	Not allowed
2	Missing segment	Not allowed
3	Short	Not allowed
4	Backlight no lighting	Not allowed
5	TP no function	Not allowed



11.2 可靠性试验 (RELIABILITY TEST)

NO	ITEM	CONDITION	STANDARD
1	High Temp. Storage	70°C, 12 hours	1. Functional test is OK. Missing Segment, short, unclear segment, non-display, display abnormally and liquid crystal leak are un-allowed. 2. No low temperature bubbles, end seal loose and fall, frame rainbow.
2	Low Temp. Storage	-20°C, 12 hours	
3	High Temp. Operation	60°C, 12 hours	
4	Low Temp. Operation	-20°C, 12 hours	
5	High temperature and high Humidity storage	40°C, 90%RH, 12 hours	
6	Thermal and cold shock	Static state, -20°C (30 Min) ~ 70°C (30 Min) ~ -20°C (30Min), packaging, 10 cycles	1. Function test is OK. 2. No glass crack, chipped glass, end seal loose and fall, epoxy frame crack and so on. 3. No structure loose and fall.
7	Vibration test	Packaging, Frequency : 10-55Hz Amplitude : 1.0mm, Each direction on X, Y axe 0.5 hours, circle 2 hours	
8	Dropping test	Pack products into the carton box. Drop it from 80cm height to ground. Once for each side of the carton	

NOTE:

10.2.1 The reliability items will be fully performed in new sample qualification,

11.2.2 The reliability status will be tested as monitor during mass production. Individual reliability test shall be

performed by lot, Moreover, the individual reliability item shall be decided according to reliability plan.

11.2.3 All samples are inspected after keeping in the room with normal temperature and humidity for 2 hours or above.

11.2.4 Vibration test: It is not necessary to test for those products without assembly frame, back light, PCB and so on.

11.2.5 Dropping test: It is necessary for affirming new package.

11.2.6 For the high temperature and high humidity test, pure water of over 10 MΩ.cm should be used.

11.2.7 Each test item applies for test LCM only once. Then tested LCM cannot be used again in any other test item.

11.2.8 The quantity of LCM examination for each test item is 5pcs to 10pcs.

11.3 安全说明 (Safety instructions)

11.3.1 If the LCD panel breaks, be careful not to get any liquid crystal substance in your mouth.

11.3.2 If the liquid crystal substance touches your skin or clothes, please wash it off immediately by using soap and water.



11.4 操作注意事项(Handling Precautions)

- 11.4.1 Avoid static electricity damaging the LSI.
- 11.4.2 Do not remove the panel or frame from the module .
- 11.4.3 The polarizing plate of the display is very fragile . So, please handle it very carefully.
- 11.4.4 Do not wipe the polarizing plate with a dry cloth, as it may easily scratch the surface of the plate.
- 11.4.5 The color tone of display and background of LCM has the possibility to be changed in the storage temperature range.
- 11.4.6 Pay attention to the working environment, as the element may be destroyed by static electricity.
 - Be sure to ground human body and electric appliance during work.
 - Avoid working in a dry environment to minimize the generations of static electricity.
 - Static electricity may be generated when the protective film is fast peeled off.
- 11.4.7 When soldering the terminal of LCM, make certain the AC power source of soldering iron does not leak.
- 11.4.8 If the display surface becomes contaminated ,breathe on the surface and gently wipe it with a soft-dry- clean cloth .If it is heavily contaminated ,moisten cloth with the following solvent(ex:Ethyl alcohol).Solvents other than those above-mentioned may damage the polarizer(Especially ,do not use them .ex: Warter / Ketone)

11.5 操作说明(Operation instructions)

- 11.5.1 It is recommended to drive the LCD within the specified voltage limits, try to adjust the operating voltage for the optimal contrast, the color and contrast of LCD panel will varies at different temperature.
- 11.5.2 Response time is greatly delayed at low operating temperature range. However, this does not mean the LCD will be out of the order, It will recover when it returns to the specified temperature range.
- 11.5.3 If the display area is pushed hard during operation, the display will become abnormal.
- 11.5.4 Do not operate the LCD at the environments over the specified conditions, this may cause damage on the LCD and shorten the lifetime.

11.6 储存说明: (Storage instructions)

- 11.6.1 Store LCDs in a sealed polyethylene bag.
- 11.6.2 Store LCDs in a dark place, Do not expose to sunlight or fluorescent light. Keep the temperature between 0°Cand 35°C.
- 11.6.3 Avoid the polarizer touch any other object, (It is recommended to store them in the container in which they were shipped.)

11.7 保修说明(Limited Warranty)

- 11.7.1 LEAD will replace or repair any of its LCD modules, which are found to be defective, when inspected in accordance with LEAD LCM acceptance standards (copies available upon request) for a period of 12 months from ink- print date on product
- 11.7.2 Any defects must be returned to LEAD within 60 days since ship-out. Confirmation of such date shall be based on freight documents. The warranty liability of LEAD limited to repair and/or replacement on defects above (7.1,7.2)
- 11.7.3 No warranty can be granted if the precautions stated above have been disregarded. The typical samples are as below:
 - LCD glass crack/break
 - PCB outlet is damaged or modified.



- PCB conductors damaged.
- Circuit modified with by grinding, engraving or painting varnish.
- FPC crack

11.7.4 Modules must be returned with sufficient description of the failures of defects. Any connectors or cable installed by the customer must be removed completely without damaging the PCB outlet, conductors and terminals. Modules must be packed with the container in which they were shipped.

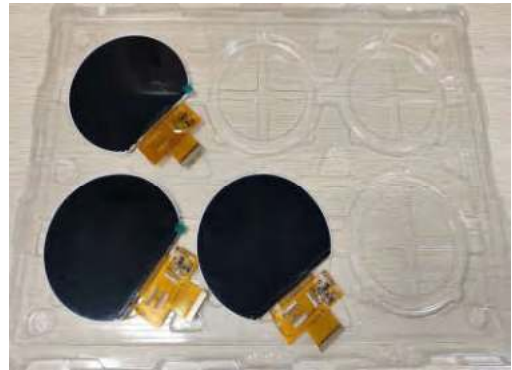

十二. 包装方法(Packing method)

-----TBD-----