



SPECIFICATION FOR TFT LCD MODULE

CUSTOMER : _____

CUSTOMER MODULE : _____

HL MODEL : HG070WS055

Preliminary Specification

Final Specification

Customer Confirmation column:

Approved by : _____ Dept. : _____ Data : _____

Please return one of the copies of the specification with your signature to us within two weeks after you receive this document. If it is not returned, we will assume that you agree to the entire contents of this specification document.

Designed by	Checked by	Approved by



TABLE OF CONTENTS

No.	CONTENTS	PAGE
	REVISION STATUS.....	2
	TABLE OF CONTENTS	3
1.	GENERAL DESCRIPTION.....	4
2.	MECHANICAL SPECIFICATION	5
3.	PIN DESCRIPTION.....	6
4.	ELECTRICAL CHARACTERISTICS	8
5.	INPUT SIGNAL TIMING.....	11
7.	QUALITY ASSURANCE SYSTEM.....	18
8.	GENERAL PRECAUTION	19



1. GENERAL DESCRIPTION

1.1 DESCRIPTION

HG070WS055 is a color active matrix thin film transistor (TFT) TN liquid crystal display (LCD) that uses amorphous silicon TFT as a switching device. It is composed of a TFT LCD panel, Driver IC ,FPC and Backlight.

1.2 FEATURES:

No.	Item	Specification	Unit
1	Panel Size	7.0"	inch
2	Number of Pixels	1024 x3(RGB) x600	pixels
3	Active Area	153.6(H)x 90 (V)	mm
4	Pixel Pitch	0.05 X 0.15	mm
5	Outline Dimension	100.0x164.9x3.5	mm
6	Number of Colors	16.7M	-
7	Display Mode	Normally Black	-
8	Viewing Direction	ALL	-
9	Pixel Arrangement	RGB vertical stripe	-
10	Luminance (cd/m ²)	550	nit
11	Contrast Ratio	800(TYP.)	
12	Surface Treatment	Anti-glare	-
13	Interface	TTL	-
14	Backlight	White LED	-
15	Operation Temperature	-20-70	°C
16	Storage Temperature	-30-80	°C
17	Weight	TBD	g



2. MECHANICAL SPECIFICATION

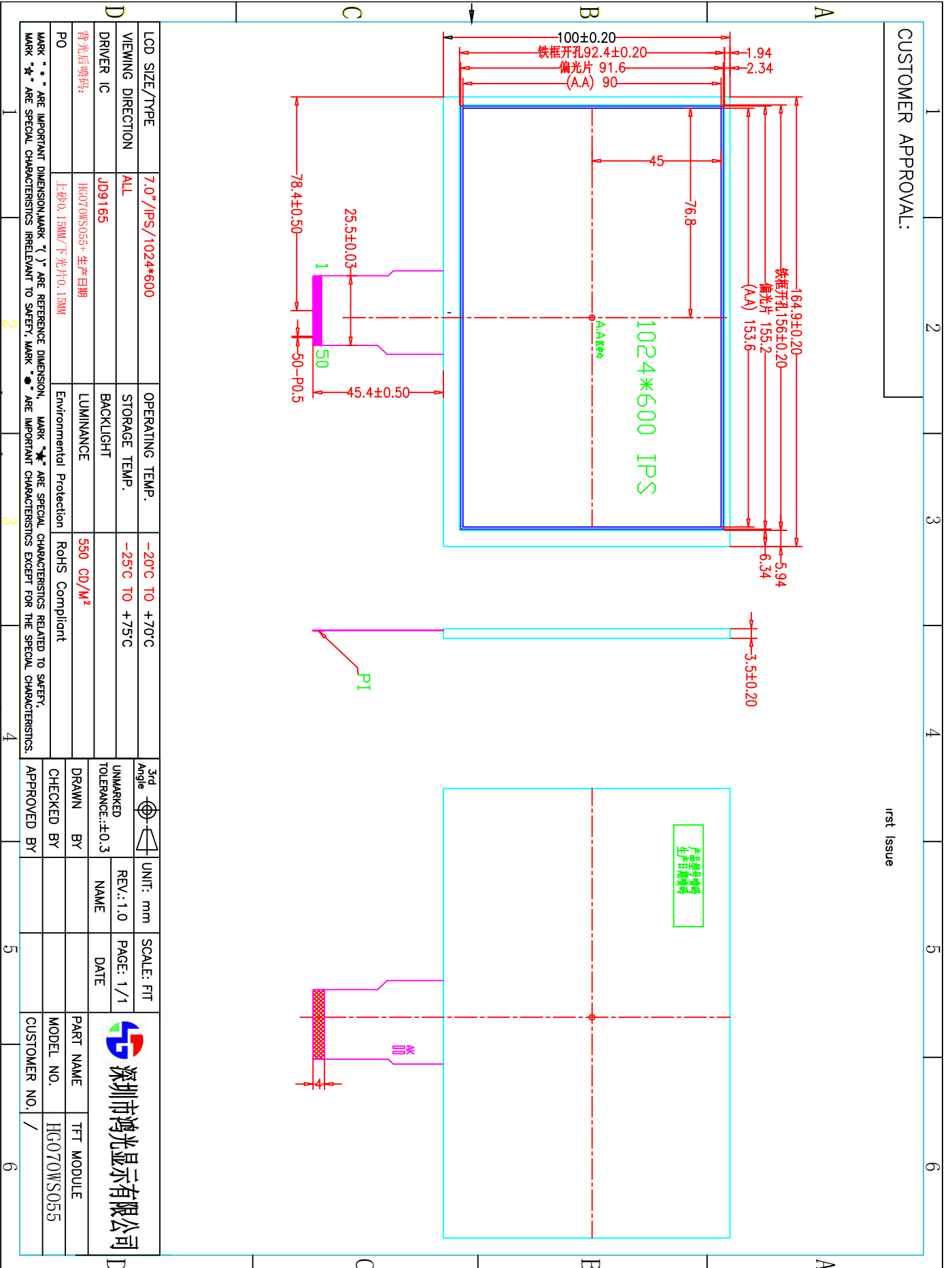



3. PIN DESCRIPTION

PIN NO.	SYMBOL	I/O	FUNCTION DESCRIPTIONS
1	LED-A	P	Power for LED backlight (Anode)
2	LED-A	P	Power for LED backlight (Anode)
3	LED-K	P	Power for LED backlight (Cathode)
4	LED-K	P	Power for LED backlight (Cathode)
5	GND	P	Power Ground
6	VCOM	P	TFT Common Voltage input
7	DVDD	P	Power for Digital Circuit
8	MODE	I	DE/SYNC mode select
9	DE	I	Data enable signal
10	VS	I	Vertical sync input.
11	HS	I	Horizontal sync input.
12~19	B7~B0	I	Blue Data Input
20~27	G7~G0	I	Green Data Input
28~35	R7~R0	I	Red Data Input
36	GND	P	Power Ground
37	DCLK	I	Sample Clock Input
38	GND	P	Power Ground
39	L/R	I	Left / right selection
40	U/D	I	Up/down selection
41	VGH	P	Positive Power for TFT Gate ON
42	VGL	P	Negative Power for TFT Gate OFF
43	AVDD	P	Power for Analog Circuit
44	RESET	I	Global reset pin.
45	NC	/	No connection
46	VCOM	P	TFT Common Voltage input
47	DITHB	I	Dithering function
48	GND	P	Power Ground
49	NC	/	No connection
50	NC	/	No connection

I: input, 0: output, P: Power

Note 1: DE/SYNC mode select. Normally pull high.

When select DE mode, MODE=" 1" , VS and HS must pull high.

When select SYNC mode, MODE=" 0" , DE must be grounded.

Note 2: When input 18 bits RGB data, the two low bits of R,G and B data must be grounded.

Note 3: Data shall be latched at the falling edge of DCLK.

Note 4: Selection of scanning mode

Setting of scan control input		Scanning direction
U/D	L/R	
GND	DV _{DD}	Up to down, left to right
DV _{DD}	GND	Down to up, right to left
GND	GND	Up to down, right to left
DV _{DD}	DV _{DD}	Down to up, left to right



4. ELECTRICAL CHARACTERISTICS

4.1 ABSOLUTE MAXIMUM RATINGS

Ta = 25°C ± 2

Item	Symbol	Min.	Max.	Unit	Conditions
Digital Supply Voltage	VDD	-0.5	5.5	V	
TFT Gate on voltage	VGH	-0.3	42	V	
TFT Gate off voltage	VGL	-42	0.3	V	
Analog power supply voltage	AVDD	-0.5	12.5	V	

4.2 TFT LCD MODULE

4.2.1 Operating Conditions

Symbol	Min.	Typ.	Max.	Unit
VGH	19.5	20	20.5	V
VGL	-6.5	-7	-7.5	V
VCOM	3.18	(3.68)	4.18	V

Symbol	Black	50% Gray	White	Unit
VDH	0.2	2.6	5.4	V
VDL	-0.2	-2.6	-5.4	V

Reference Voltage



4.4 POWER ON/OFF SEQUENCE

4.4.1 Power-On/Off Timing Sequence:

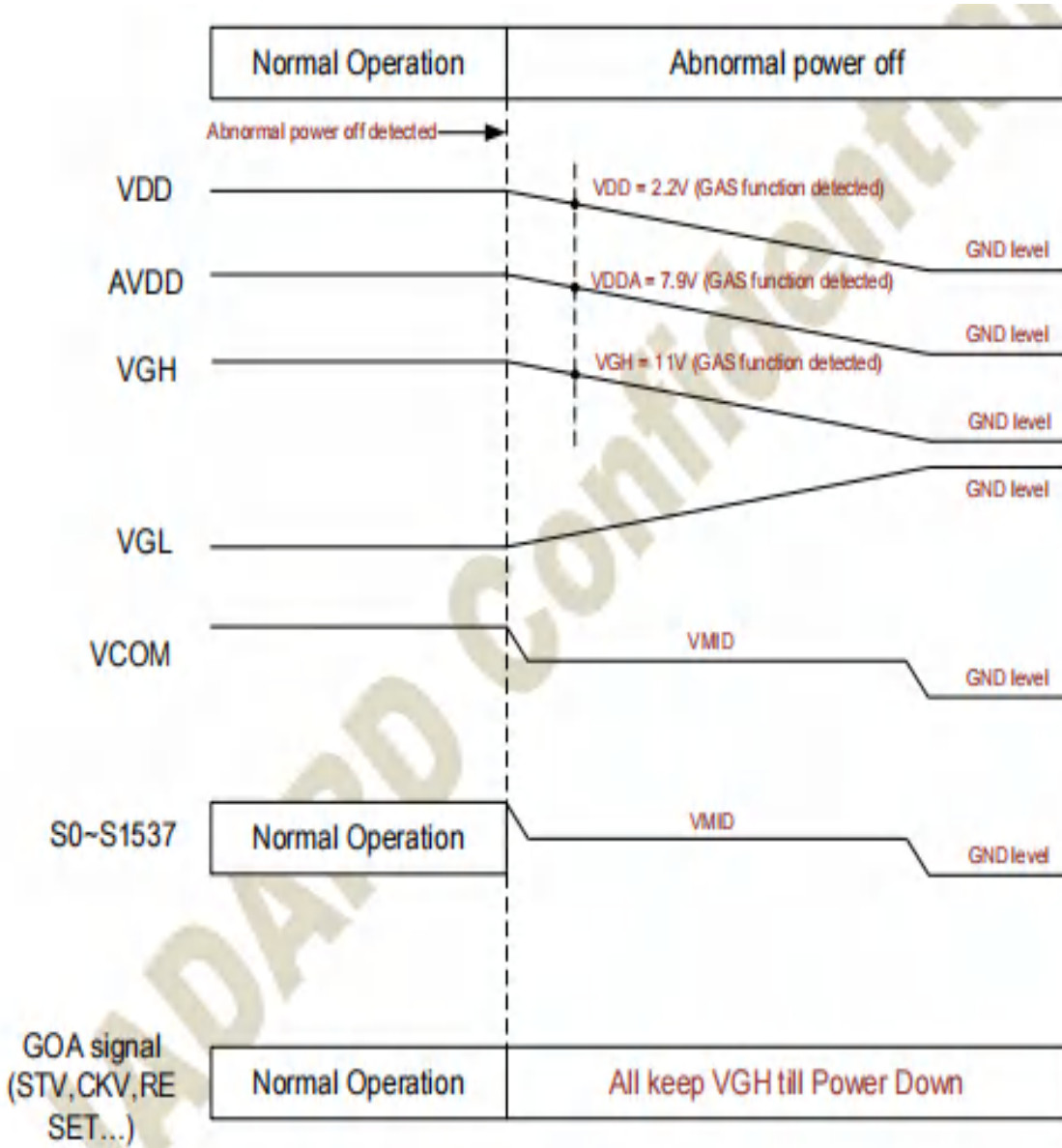

Figure 5.12: GAS discharge timing



4.5BACK LIGHT

Item	Symbol	Values			Unit	Remark
		Min.	Typ.	Max.		
LED Current	I _{LED}	-	160	-	mA	Total LED
Forward Voltage	V _F	11.5	12.0	12.5	V	I _F =160mA
Reverse Current	I _r	-	-	50	uA	V _R =5V, 1LED
Power dissipation	P _d	990			mW	Total LED
Peak forward current	I _{fp}	30			mA	1LED
Reverse voltage	V _R	5			V	1LED

※1. Internal Circuit Diagram



5.INPUT SIGNAL TIMING

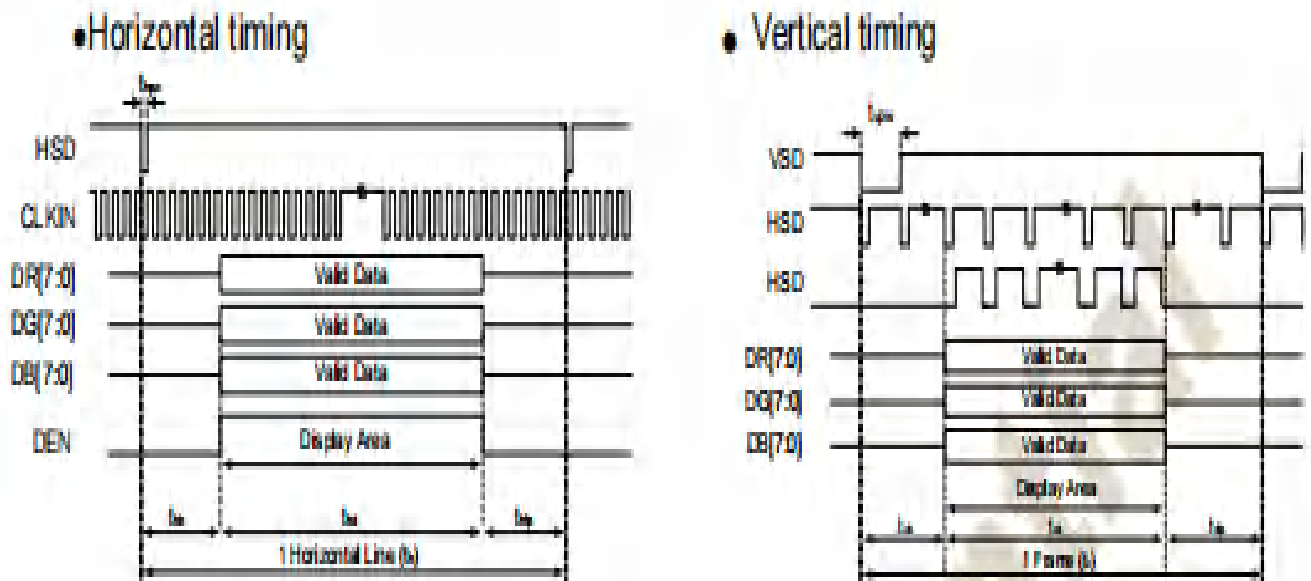

Figure 6.1: 24-bit parallel RGB mode horizontal/vertical input timing

5.1.1 Timing Diagram

24-bit parallel RGB Input Timing	Symbol	1024RGBx768			1024RGBx600			800RGBx600			Unit
		Min	Typ	Max	Min	Typ	Max	Min	Typ	Max	
DCLK Frequency	f	52	65	71	40.8	51.2	67.2	32.6	39.6	62.4	MHZ
Horizontal Total	t _{ht}	1114	1344	1400	1114	1344	1400	890	1000	1300	DCLK
Hsync Pulse width	t _{hs}	1	24	HBP-1	1	24	HBP-1	1	24	HBP-1	DCLK
Horizontal Back Porch	t _{hb}	60	160	160	60	160	160	60	88	250	DCLK
Horizontal Valid Data	t _{hd}	1024			1024			800			DCLK
Horizontal Front Porch	t _{hf}	30	160	216	30	160	216	30	112	250	DCLK
Vertical Total	t _{vt}	778	806	845	610	635	800	610	660	800	THT
Vsync Pulse Width	t _{vs}	1	2	VBP-1	1	2	VBP-1	1	2	VBP-1	THT
Vertical Back Porch	t _{vb}	8	23	33	8	23	100	8	39	100	THT
Vertical Valid Data	t _{vd}	768			600			600			THT
Vertical Front Porch	t _{vf}	2	15	44	2	12	100	2	21	100	THT

24-bit parallel RGB Input Timing	Symbol	640RGBx480			480RGBx272			Unit
		Min	Typ	Max	Min	Typ	Max	
DCLK Frequency	f	32.6	39.6	53.4	24.8	32.6	37.6	MHZ
Horizontal Total	t _{ht}	890	1000	1114	630	890	950	DCLK
Hsync Pulse width	t _{hs}	1	24	HBP-1	1	24	HBP-1	DCLK
Horizontal Back Porch	t _{hb}	140	88	220	180	210	240	DCLK
Horizontal Valid Data	t _{hd}	640			480			DCLK
Horizontal Front Porch	t _{hf}	110	272	254	170	200	230	DCLK
Vertical Total	t _{vt}	610	660	800	498	610	660	THT
Vsync Pulse Width	t _{vs}	1	2	VBP-1	1	2	VBP-1	THT
Vertical Back Porch	t _{vb}	28	39	160	126	180	210	THT
Vertical Valid Data	t _{vd}	480			272			THT
Vertical Front Porch	t _{vf}	102	141	160	100	158	178	THT



6. OPTICAL CHARACTERISTICS

The optical characteristics are measured under stable conditions at 25°C (Room Temperature) :

Item	Symbol	Conditions	Min.	Typ.	Max.	Unit	Note
Viewing Angle	θ_R	Horizontal (Right) CR = 10 (Left)	-	85	-	degree	1, 4
	θ_L		-	85	-		
	ϕ_H	Vertical (Upper) CR = 10 (Lower)	-	85	-		
	ϕ_L		-	85	-		
Transmittance	%		4.9%				
Cross talk	%			4.0%			1, 2
Response Time	T_{RT}	Rising + Falling	-	8	-	msec	1, 3
Color / Chromaticity Coodinates	Red	Rx	CIE 1931	TBD	TBD	TBD	1, @C-light
		Ry		TBD	TBD	TBD	
	Green	Gx		TBD	TBD	TBD	
		Gy		TBD	TBD	TBD	
	Blue	Bx		TBD	TBD	TBD	
		By		TBD	TBD	TBD	
	White	Wx		0.283	0.313	0.343	
		Wy		0.299	0.329	0.359	
	NTSC	%			-	50	



Note 1: Measurement method

The LCD module should be stabilized at given temperature for 30 minutes to avoid abrupt temperature change during measuring. In order to stabilize the luminance, the measurement should be executed after lighting Backlight for 30 minutes in a stable, windless and dark room, and it should be measured in the center of screen.

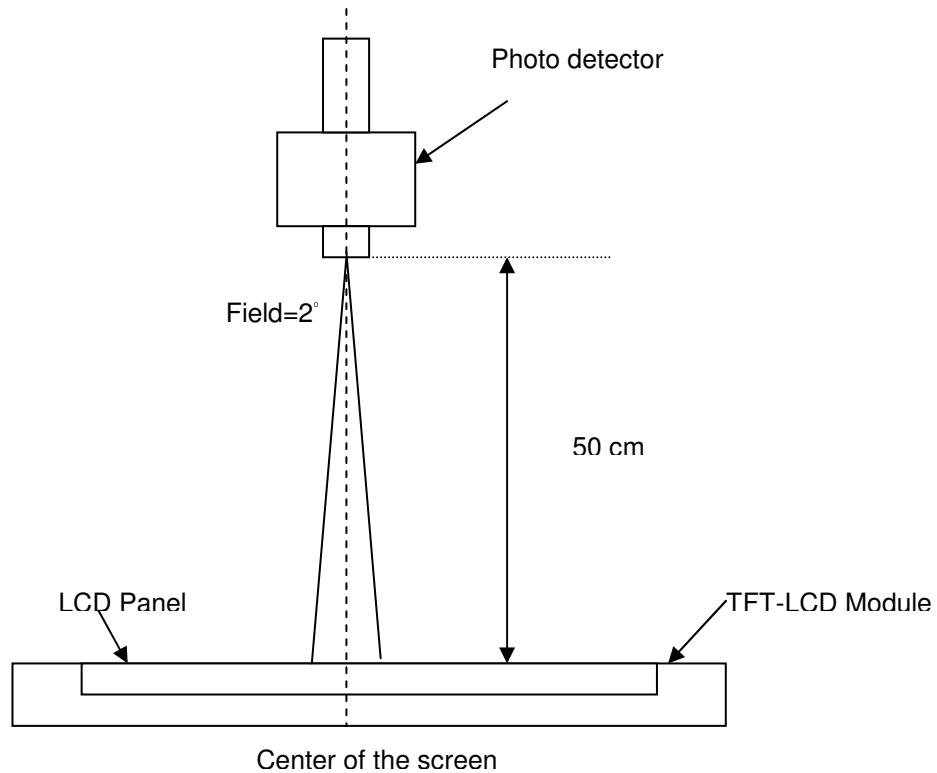

Note 2 : Definition of Cross Talk (CT)

$$CT = |Y_B - Y_A| / Y_A \times 100 (\%)$$

Where

Y_A = Luminance of measured location without gray level 0 pattern (cd/m²)

Y_B = Luminance of measured location with gray level 0 pattern (cd/m²)

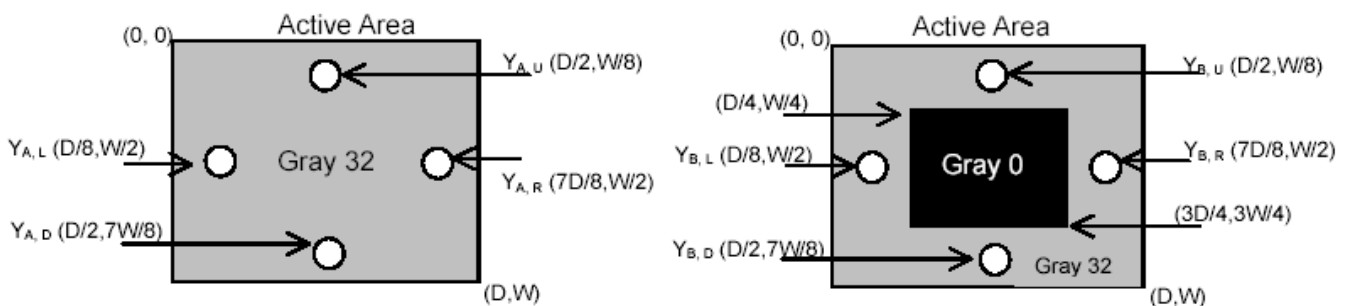



7. QUALITY ASSURANCE SYSTEM

7.1 TEMPERATURE AND HUMIDITY

Test Item	Test Condition	Remark
HighTemperatureStorage	Ta=70°C; 120hrs	IEC60068-2-1 : 2007 GB2423.2-2008
Low Temperature Storage	Ta=-30°C; 120hrs	IEC60068-2-1 : 2007 GB2423.1-2008
High Temperature Operation	Ta=70°C , 120Hrs	IEC60068-2-1 : 2007 GB2423.2-2008
Low Temperature Operation	Ta=-20°C; 120hrs	IEC60068-2-1 : 2007 GB2423.1-2008
High Temperature High Humidity Operation	Ta=60°C , 90%RH , 120Hrs(no condensation)	IEC60068-2-78 : 2001 GB/T2423.3-2006
Thermal Shock	-30°C (0.5h) ~ 80°C (0.5h) / 100cycles	Start with cold temperature , End with high temperature , IEC60068-2-14:1984,GB2423.22-2002
Image Sticking	25°C ; 4hrs	Note1

Note1:Condition of image sticking test :25°C±2°C

Operation with test pattern sustained for 4hrs,then change to gray pattern immediately.after 5 mins,the mura must be disappeared completely

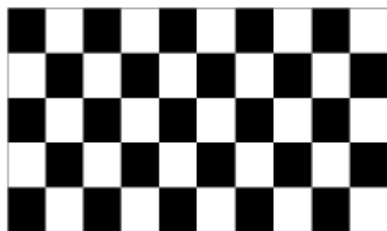

(a) Test Pattern (chess board Pattern)



(b) Gray Pattern

7.2 VIBRATION&SHOCK

Test item	Conditions	Remark
Packing Shock (non-operation)	980m/s ² ,6ms, ±x,y,z 3times for direction	IEC60068-2-27 : 1987 GB/T2423.5-1995
Packing Vibration (non-operation)	Frequency range:10 HZ~50HZ Stroke:1.0mm,sweep:10 HZ ~50HZ x,y,z 1 hours for each direction	IEC60068-2-32 : 1990 GB/T2423.8-1995

7.3ESD

Test item	Conditions	Remark	
Electro Static Discharge Test (non-operation)	150pF , 330Ω , Contact:±4KV,Air:±8KV	1	IEC61000-4-2 : 2001 GB/T17626.2-2006
	200pF , 0Ω , ±200V contact test	2	

Note: Measure point :

1. LCD glass and metal bezel
2. IF connector pins



8. GENERAL PRECAUTION

8.1 SAFETY

1. Do not swallow any liquid crystal, even if there is no proof that liquid crystal is poisonous.
2. If the LCD panel breaks, be careful not to get liquid crystal to touch your skin.
3. If skin is exposed to liquid crystal, wash the area thoroughly with alcohol or soap.

8.2 STORAGE CONDITIONS

1. Store the panel or module in a dark place where the temperature is $23\pm 5^{\circ}\text{C}$ and The humidity is below $50\pm 20\%\text{RH}$.
2. Store in anti-static electricity container.
3. Store in clean environment, free from dust, active gas, and solvent.
4. Do not place the module near organics solvents or corrosive gases.
5. Do not crush, shake, or jolt the module.

8.3 HANDLING PRECAUTIONS

1. Avoid static electricity which can damage the CMOS LSI.
2. The polarizing plate of the display is very fragile. So, please handle it very carefully.
3. Do not give external shock.
4. Do not apply excessive force on the surface.
5. Do not wipe the polarizing plate with a dry cloth, as it may easily scratch the Surface of plate.
6. Do not use ketonics solvent & Aromatic solvent, use with a soft cloth soaked with a cleaning naphtha solvent.
7. Do not operate it above the absolute maximum rating.
8. Do not remove the panel or frame from the module.
9. When the module is assembled, it should be attached to the system firmly, Be careful not to twist and bend the module.
10. Wipe off water droplets or oil immediately. If you leave the droplets for a long time, staining and discoloration may occur.
11. If the liquid crystal material leaks from the panel, it should be kept away from the eyes or mouth In case of contact with hands, legs or clothes, it must be washed away thoroughly with soap.

8.4 WARRANTY

1. The period is within twelve months since the date of shipping out under normal using and storage conditions.
2. Do not repaired or modified the LCM. It may cause function to lose efficacy, Starry does not warrant the LCM.
3. All process and material comply ROHS.