



SPECIFICATION FOR TFT LCD MODULE

CUSTOMER : _____

CUSTOMER MODULE : _____

HL MODEL : HG043WV023T01

Preliminary Specification

Final Specification

Customer Confirmation column:

Approved by : _____ Dept. : _____ Date : _____

Please return one of the copies of the specification with your signature to us within two weeks after you receive this document. If it is not returned, we will assume that you agree to the entire contents of this specification document.

Designed by	Checked by	Approved by



CONTENTS

No.	ITEM	PAGE
1.	GENERAL INFORMATION	4
2.	DIAGRAM FOR LCM	5
3.	I/O CONNECTION & BLOCK DIAGRAM	6~7
4.	ELECTRICAL CHARACTERISTICS	8~12
5.	ELECTRO-OPTICAL CHARACTERISTICS	13~15
6.	RELIABILITY TEST CONDITIONS	16
7.	INSPECTION STANDARDS	17~18
8.	PACKAGE DRAWING	19



1. GENERAL INFORMATION

1.1 features

- 1) Structure: TFT PANNEL+IC+FPC+BL+CTP
- 2) IPS Type LCD 800 dot-segment and 480 dot-common outputs
- 3) 252K Color can be selected by software
- 4) White LED back light
- 5) RGB-24 interface
- 6) Operation Temperature : -20~70℃
- 7) Storage Temperature : -30~80℃
- 8) CTP cover lens : Asahi
- 9) CTP structure : G+G
- 10) LED life time: -/

1.2 General specification

Item of	Contents	Unit
Panel Size	4.3	inch
LCD Type	a-si/TRANSMISSIVE	/
Display mode	Normally Black	/
Pixel arrangement	800*3 (RGB)*480	Dots
Active Area	95.04 x 53.86	Mm
Module area (W*H*T)	105.5*67.2*4.78	Mm
Recommended Viewing Direction	ALL	0' clock
LCM-IC	TBD	/
TP-IC	GT911	
Interface	RGB-24	/
Luminance for LCM+TP	1000	cd/m2
Weight	TBD	g



3. I/O CONNECTION & BLOCK DIAGRAM

3.1 I/O connection

LCM Pin NO.	Symbol	I/O	Description
1	LED_K	P	Power supply for LED-
2	LED_A	P	Power supply for LED+
3	GND	P	Power Ground
4	VCC	P	Power supply to the internal logic power regulator
5-12	R0-R7	I	RED data
13-20	G0-G7	I	GREEN data
21-28	B0-B7	I	BLUE data
29	GND	P	Power Ground
30	DCLK	I	Parallel RGB clock input
31	DISP	I	Display control / standby mode selection
32	HSYNC	I	Horizontal sync signal; negative polarity.
33	VSYNC	I	Vertical sync signal; negative polarity.
34	DE	I	DATA INPUT Enable
35	NC	-	No connect
36	GND	P	Power Ground
37-40	NC	-	No connect

I: Input; O: Output; P: Power

TP Pin NO.	Symbol	Description
1	RESET	复位脚
2	VDD	电源正极, 2.8V
3	GND	Power Ground
4	INT	中断信号
5	SCL	IIC 时钟信号
6	SDA	IIC 数据信号



3.2 block diagram

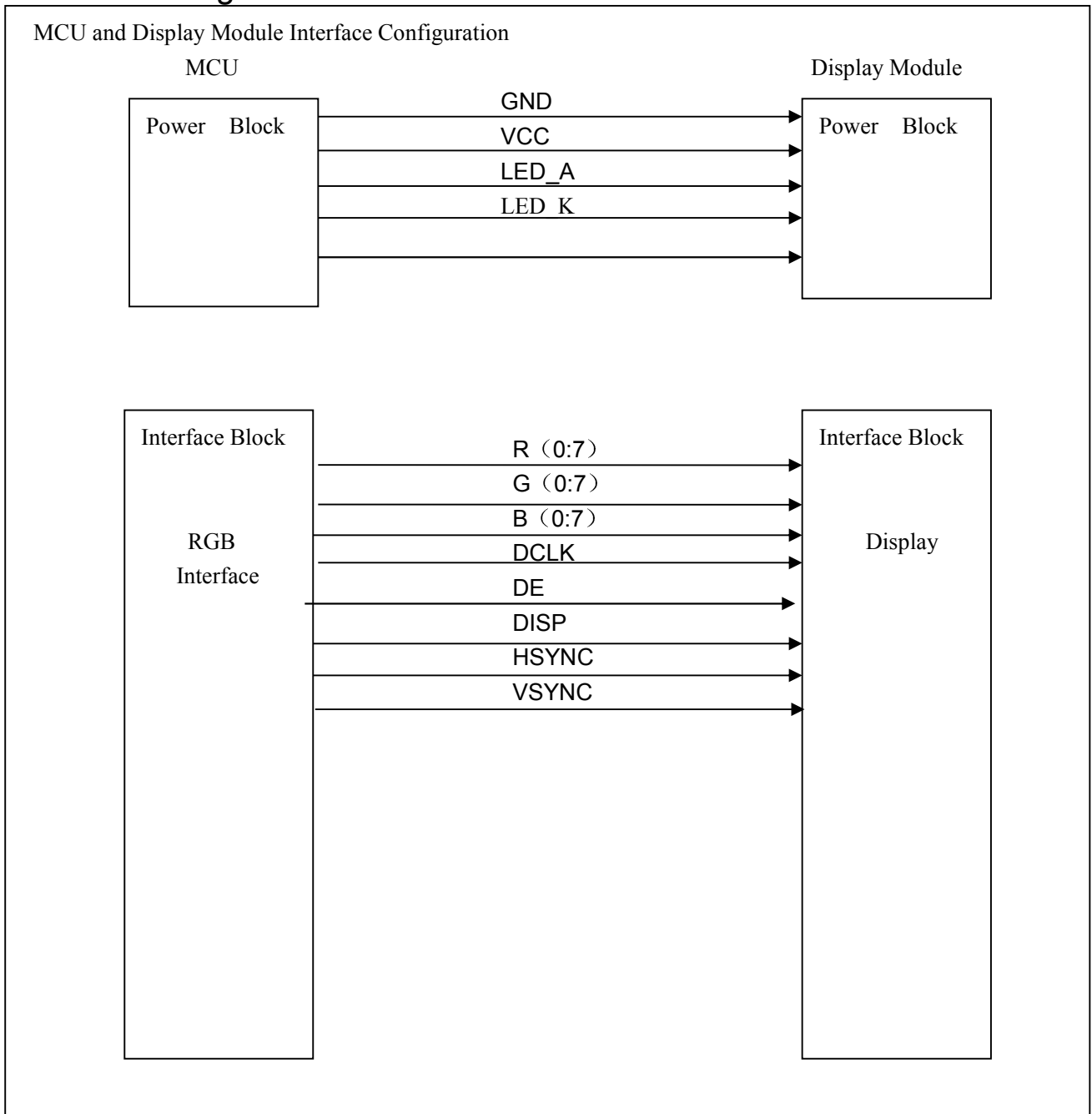



4. ELECTRICAL CHARACTERISTICS

4.1 Absolute Maximum Ratings

Item	Symbol	Values		Unit	Remark
		Min.	Max.		
Power voltage	V_{DD}	-0.5	5.0	V	
Input signal voltage	Logic input	-0.5	5.0	V	
Operation temperature	T_{OP}	-20	70	°C	Note 3, 4
Storage temperature	T_{ST}	-30	80	°C	Note 3, 4
LED Reverse Voltage	V_R	-	1.2	V	Each LED Note 2
LED Forward Current	I_F	-	25	mA	Each LED

Note 1: The absolute maximum rating values of this product are not allowed to be exceeded at any times. A module should be used with any of the absolute maximum ratings exceeded, the characteristics of the module may not be recovered, or in an extreme condition, the module may be permanently destroyed.

Note 2: V_R Conditions: Zener Diode 20mA

Note 3: 90% RH Max. (Max wet temp. is 60°C)

Maximum wet-bulb temperature is at 60°C or less. And No condensation (no drops of dew)

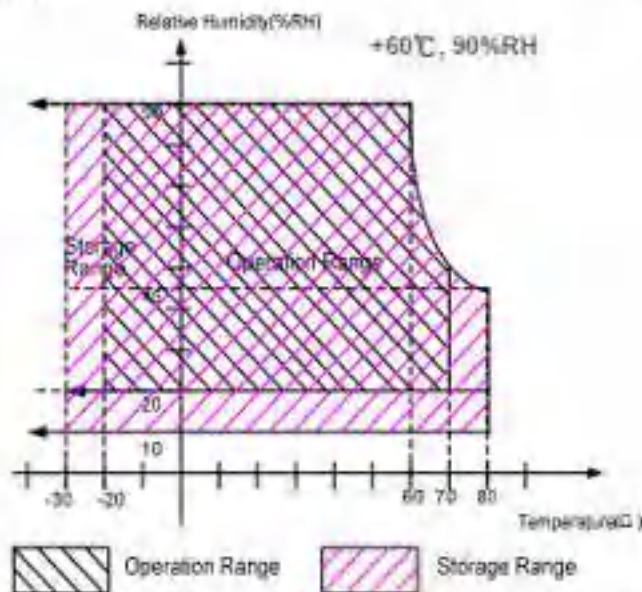

Note 4: In case of temperature below 0°C, the response time of liquid crystal (LC) becomes slower and the color of panel darker than normal one.



4.2 Typical operation conditions

Item	Symbol	Values			Unit	Remark
		Min.	Typ.	Max.		
Power voltage	V_{DD}	3.1	3.3	3.5	V	
Current for Driver	I_{VDD}	-	TBD	25	mA	$V_{DD} = 3.3V$
Input logic high voltage	V_{IH}	$0.8V_{DD}$	-	V_{DD}	V	Note 1
Input logic low voltage	V_{IL}	GND	-	$0.2V_{DD}$	V	

Note1: CLK, DE, R0~ R7, G0~ G7, B0~ B7.

4.3 Backlight Driving Conditions

Item	Symbol	Values			Unit	Remark
		Min	Typ	Max		
Voltage for LED Backlight	VL	19.6	22.4	23.8	V	Note2
Current for LED Backlight	IL		40		mA	
LED life time	-	30000	-	-	Hr	Note1

Note 1: The “LED life time” is defined as the module brightness decrease to 50% original brightness that the ambient temperature is 25 °C and $I_L=40mA$. The LED lifetime could be decreased if operating I_L is larger than 40 mA.

Note 2: The LED Supply Voltage is defined by the number of LED at $T_a=25\text{ °C}$ and $I_L=40mA$.



4.4 Power Sequence

To prevent a latch-up or DC operation of the LCD module, the power on/off sequence should be as the diagram below.

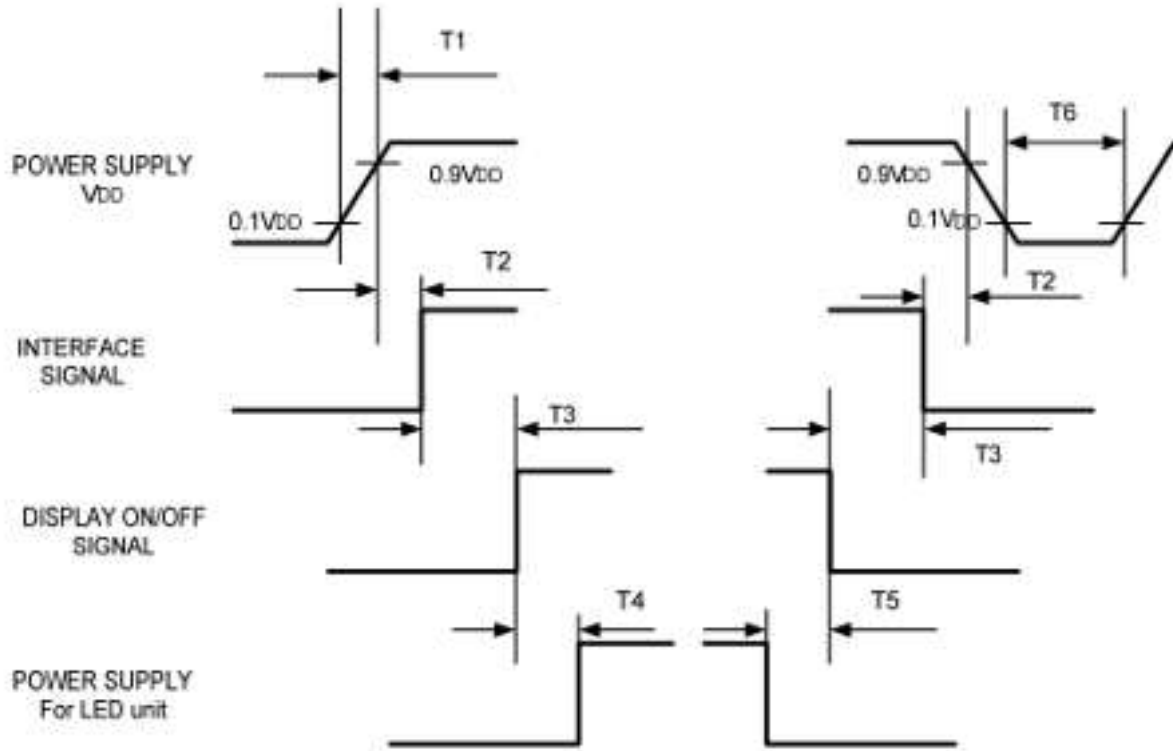

Symbol	Specification	Symbol	Specification
T1	$0 \leq T1 \leq 10 \text{ msec}$	T4	$160 \text{ msec} \leq T4$
T2	$0 \leq T2 \leq 100 \text{ msec}$	T5	$160 \text{ msec} \leq T5$
T3	$0 \leq T3 \leq 200 \text{ msec}$	T6	$1 \text{ msec} \leq T6$



4.5 Timing Characteristics

4.5.1 Timing Conditions

Parallel DE mode RGB input timing table

- Horizontal timing

Parameter	Symbol	Spec.			Unit
		Min.	Typ.	Max.	
Horizontal Display Area	thd		800		DCLK
DCLK frequency	fcik	-	30	50	MHz
One Horizontal Line	th	889	928	1143	DCLK
HS pulse width	thpw	1	48	255	DCLK
HS Back Porch (Blanking)	thb		88		DCLK
HS Front Porch	thfp	1	40	255	DCLK
DE mode Blanking	th-thd	85	128	512	DCLK

- Vertical timing

Parameter	Symbol	Spec.			Unit
		Min.	Typ.	Max.	
Vertical Display Area	tvd		480		T _{in}
VS period time	tv	513	525	767	T _{in}
VS pulse width	tvpw	3	3	255	T _{in}
VS Back Porch (Blanking)	tvb		32		T _{in}
VS Front Porch	tvfp	1	13	255	T _{in}
DE mode Blanking	tv-tvd	4	45	255	T _{in}

Parallel 24-bit RGB mode

Parameter	Symbol	Min.	Typ.	Max.	Unit	Conditions
CLKIN Frequency	Fclk	-	40	50	MHz	VDD=3.0V~3.6V
CLKIN Cycle Time	Tclk	20	25	-	ns	-
CLKIN Pulse Duty	Tcwh	40	50	60	%	Tclk
Time from HSD to Source Output	T _{hso}		64		CLKIN	-
Time from HSD to LD	T _{hld}		64		CLKIN	-
Time from HSD to STV	T _{hstv}		2		CLKIN	-
Time from HSD to CKV	T _{hckv}		20		CLKIN	-
Time from HSD to OEV	T _{hoev}		4		CLKIN	-
LD Pulse Width	T _{wld}		10		CLKIN	-
CKV Pulse Width	T _{wckv}		68		CLKIN	-
OEV Pulse Width	T _{woev}		74		CLKIN	-

Table 12.1: Parallel 24-bit RGB mode



4.5.2 Timing Diagram

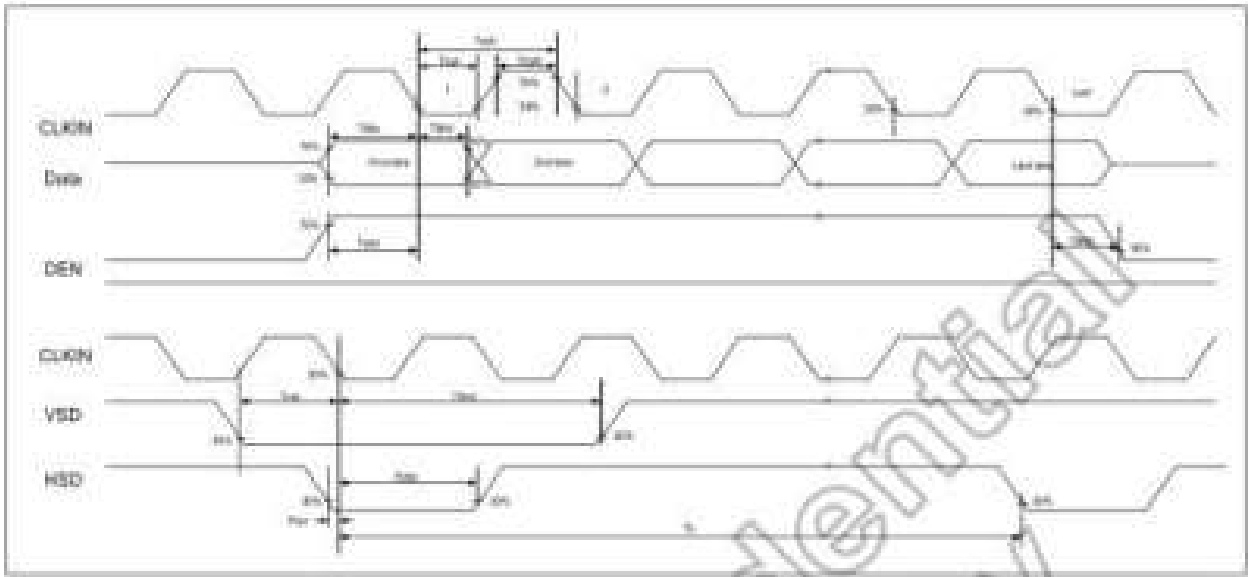

Figure 12.1: Input Clock and Data Timing Diagram

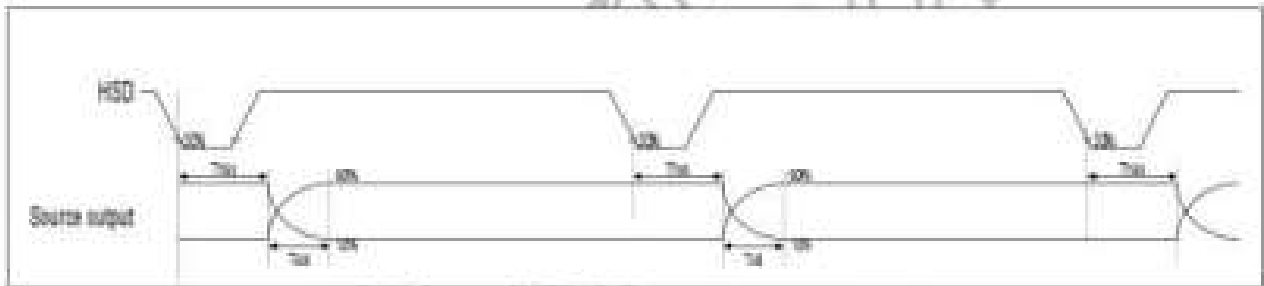

Figure 12.2: Source Output Timing Diagram

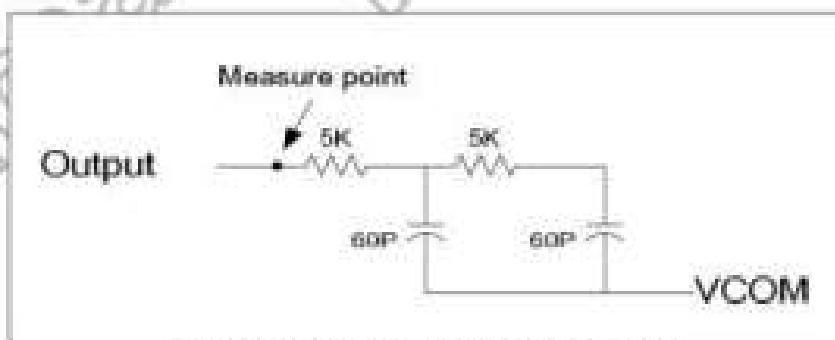

Figure 12.3: Output Load Condition



5. ELECTRO-OPTICAL CHARACTERISTICS

Parameter		Symbol	Condition	Min.	Typ.	Max.	Unit	Note
Contrast Ratio (Center point)		C/R	-	600	800	-	-	Note(1)
Luminance uniformity		U _w	θ = 0. Normal viewing angle B/L On Note(1)	80	85	-	%	Note(2)
Response Time		T _{on}		-	10	20	ms	Note(3)
		T _{off}		-	15	30	ms	
Color Chromaticity (CIE 1931)		White		W _x		0.313		Note(5)
				W _y		0.323		
		Red	R _x		0.618			
			R _y		0.343			
		Green	G _x	-0.02	0.306	+0.02		
			G _y		0.527			
		Blue	B _x		0.139			
			B _y		0.098			
Viewing Angle		Hor.	∅ 3R	70	80	-	Deg	Note(4)
			∅ 9L	70	80	-		
		Ver.	∅ 12U	70	80	-		
			∅ 6D	70	80	-		



Note1 Definition of Contrast Ratio (CR):

$$\text{Contrast ratio (CR)} = \frac{\text{Luminance measured when LCD on the "White" state}}{\text{Luminance measured when LCD on the "Black" state}}$$

Note2: Definition of Luminance Uniformity: Active area is divided into 9 measuring areas (Shown in below), every measuring point is placed at the center of each measuring area.

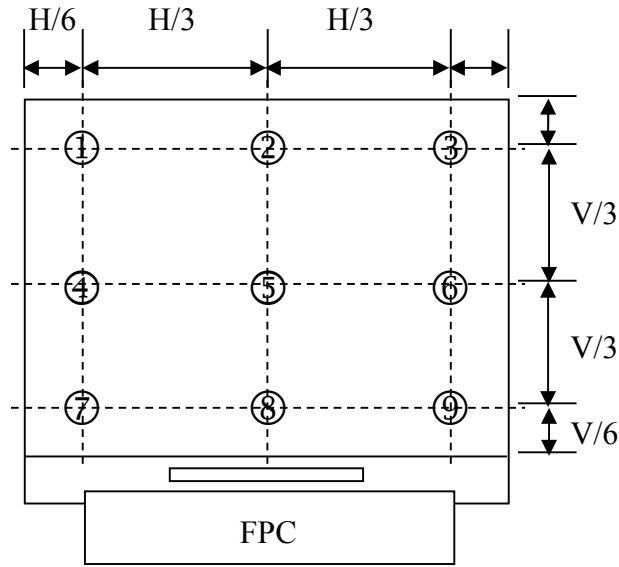

The spot locations for luminance measurement

$$\text{Luminance Uniformity} = \frac{H/6}{V/6} \times 100\%$$

B_{\max} : The measured maximum luminance of all measurement position.

B_{\min} : The measured minimum luminance of all measurement position.

Note 3: Definition of Response time: Sum of T_r and T_f

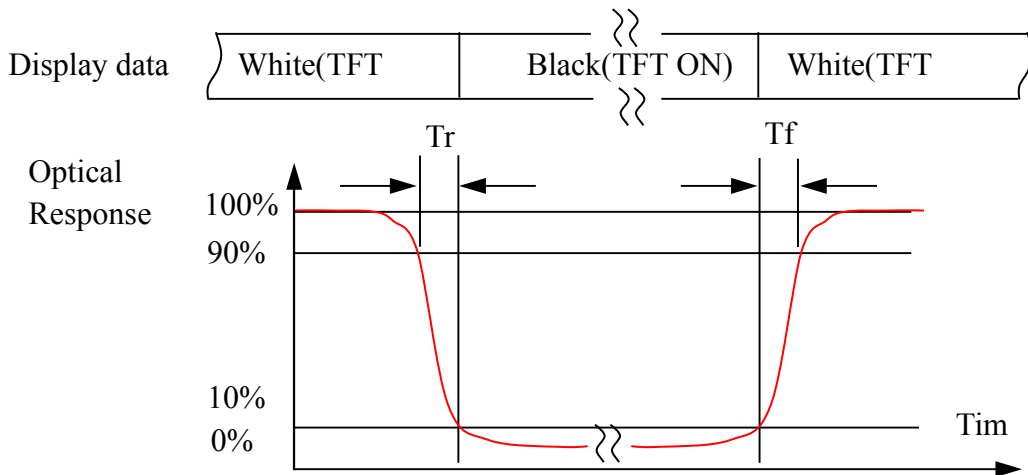



Note4.Definition of Viewing Angle: The viewing angle range that the $CR \geq 10$

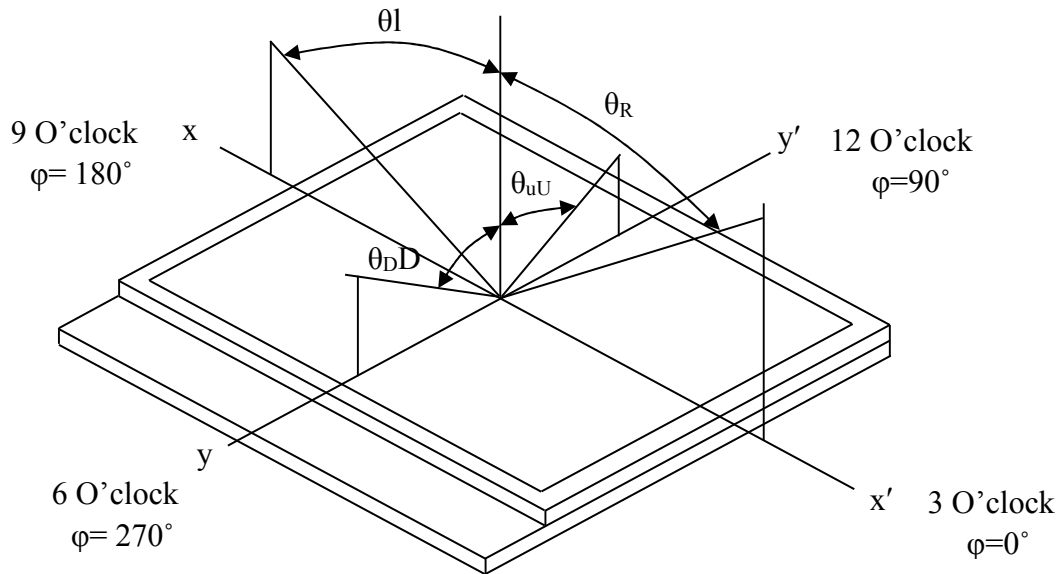

Note 5: Definition of Color Chromaticity (CIE 1931)

Color coordinate of white & red, green, blue at center point.



6. RELIABILITY TEST CONDITIONS

No	Test Item	Test Condition	STANDARD
1	High Temperature Storage	+80°C / 96Hours	1. Functional test is OK. Missing Segment, short, unclear segment, on-display, display abnormally and liquid crystal leak are un-allowed. 2. No low temperature bubbles, end seal loose and fall, frame rainbow.
2	Low Temperature Storage	-30°C / 96Hours	
3	High Temperature Operating	+70°C / 96Hours	
4	Low Temperature Operating	-20°C / 96Hours	
5	Thermal and cold shock	0°C↔+50°C x 10cycles (30min) (5min) (30min)	
6	Operate at High Temperature and Humidity	60°C x 90%RH / 24H	
7	Vibration Test	Frequency: 10Hz~55Hz~10Hz Amplitude:1.5mm, 2 hours for each direction of X, Y, Z	1. Function test is OK. 2. No glass crack, chipped glass, end seal loose and fall, epoxy frame crack and so on. 3. No structure loose and fall.
8	Dropping test	Drop to the ground from 1m height, 1 corner, 3 edges, 6 surfaces.	
9	ESD test	Contact: ±6KV Air: ±8KV 150PF/330Ω,5Points/panel,5times	The test results shall be subject to the whole machine test.

NOTE:

1. The reliability items will be fully performed in new sample qualification,
2. The reliability status will be tested as monitor during mass production. Individual reliability test shall be performed by lot, Moreover, the individual reliability item shall be decided according to reliability plan.
3. All samples are inspected after keeping in the room with normal temperature and humidity for 2 hours or above.
4. Vibration test: It is not necessary to test for those products without assembly frame, backlight, PCB and so on.
5. Dropping test: It is necessary for affirming new package.
6. For the high temperature and high humidity test, pure water of over 10 MΩ.cm should be used.
7. Each test item applies for test LCM only once. Then tested LCM cannot be used again in any other test item.
8. The quantity of LCM examination for each test item is 5pcs to 10pcs.



7. INSPECTION STANDARDS

8.1 AQL Sampling inspection standard

使用 GB/T 2828-2003 一般 II 水平, 采用正常检查一次抽样方式; 具体抽检方式参照《成品检验管理程序》、《抽样管理规范》

缺陷区分	AQL 允收水准
严重缺陷	0 收 1 退
重缺	0.4
轻缺	1.0

8.2 Inspect the condition

8.2.1 在 20—40W 日光灯的照明条件下, 样品离检查者眼睛约 30cm 处进行检查。检验方向以垂直线前后左右 45° (以时钟 3 点、6 点、9 点、12 点)

8.2.2 检验者视力需达到标准视力 1.0 以上。

8.2.3 检验者需戴静电手环、两手八个手指套。

8.2.4 外观检验者以目视检查或以菲林对比卡比对。

8.2.5 电性测试使用电测测架, 主板, 电源线及单片机。

8.2.6 若标准与规格书不符时, 以产品发行之规格书特殊检验规格、工程变更为准

8.2.7 辉色度检测请参照样品, 检测方法依照辉色度检验标准。

8.2.8 电测检验环境: 照度为 200LUX 以下, 外观检验环境: 照度为 600LUX-1000LUX, 检验时间: 1 秒-3 秒。

8.2.9 检验工具: 电测测架, 主板, 电源线及单片机, 菲林对比卡, 游标卡尺, 放大镜, 实体显微镜 (必要时) 等等。

8.3 Judgment criterion

小尺寸点、线判定标准: (6.2 寸以内)

1	点状缺陷 (磨伤、异物、针孔、凹痕、缺膜、气泡、白点、彩点、脏点)		判定 (A/B/C 区)	$D \leq 0.10$, 忽略不计, 但密集型不允许	MI	OK
				$0.1 < D \leq 0.15$, $ds \geq 10$		$N \leq 2$
				$0.15 < D \leq 0.2$, $ds \geq 10$		$N \leq 1$
				LCD 亮点: $0.15 < D$		$N \leq 1$
				$D > 0.2$		NG
			判定 (D 区)	同背面丝印油墨区杂质判定标准		
			注: 1) D 区的点状缺陷需在不影响 CTP 功能、客户组装及整机的外观的情况下, 判定 OK		MI	
2	线状缺陷 (磨伤、无感划伤、毛屑、纤维等)		判定 (A/B/C 区)	$W \leq 0.03mm$, $L \leq 3mm$, $ds \geq 10$	MI	$N \leq 2$
				$0.03mm < W \leq 0.05mm$, $L \leq 3mm$, $ds \geq 10$		$N \leq 1$
				$W > 0.05mm$ 或 $L > 3mm$		NG



中尺寸点、线判定标准：（6.2~8寸以内）

1	点状缺陷 (磨伤、异物、针孔、凹痕、缺膜、气泡、白点、彩点、脏点)		判定(A/B/C区)	$D \leq 0.10$, 忽略不计, 但密集型不允许 $0.15 < D \leq 0.25, ds \geq 10$ $0.25 < D \leq 3, ds \geq 10$ LCD亮点: $0.2 < D$ $D > 0.3$	MI	OK
			判定(D区)	同背面丝印油墨区杂质判定标准		N ≤ 2 N ≤ 1 N ≤ 1 NG
			注: 1) D区的点状缺陷需在不影响CTP功能、客户组装及整机的外观的情况下, 判定OK		MI	
2	线状缺陷 (磨伤、无感划伤、毛屑、纤维等)		判定(A/B/C区)	$W \leq 0.03mm, L \leq 3mm, ds \geq 10$ $0.03mm < W \leq 0.05mm, L \leq 3mm, ds \geq 10$	MI	N ≤ 2
				$W > 0.05mm$ 或 $L > 3mm$		N ≤ 1
						NG

大尺寸点、线判定标准：（8.1~13.3寸以内）

1	点状缺陷 (磨伤、异物、针孔、凹痕、缺膜、气泡、白点、彩点、脏点)		判定(A/B/C区)	$D \leq 0.1$, 忽略不计, 但密集型不允许 $0.15 < D \leq 0.3, ds \geq 10$ $0.3 < D \leq 0.35, ds \geq 10$ LCD亮点: $0.25 < D$ $D > 0.35$	MI	OK
			判定(D区)	同背面丝印油墨区杂质判定标准		N ≤ 2 N ≤ 1 N ≤ 1 NG
			注: 1) D区的点状缺陷需在不影响CTP功能、客户组装及整机的外观的情况下, 判定OK		MI	
2	线状缺陷 (磨伤、无感划伤、毛屑、纤维等)		判定(A/B/C区)	$W \leq 0.05mm, L \leq 5mm, ds \geq 10$ $0.05mm < W \leq 0.07mm, L \leq 5mm, ds \geq 10$	MI	N ≤ 2
				$W > 0.07mm$ 或 $L > 5mm$		N ≤ 1
						NG



8. PACKAGE DRAWING

