



# SPECIFICATION FOR TFT LCD MODULE

CUSTOMER : \_\_\_\_\_

CUSTOMER MODULE : \_\_\_\_\_

HL MODEL :     HG101WX019    

Preliminary Specification

Final Specification

Customer Confirmation column:

Approved by : \_\_\_\_\_ Dept. : \_\_\_\_\_ Data : \_\_\_\_\_

Please return one of the copies of the specification with your signature to us within two weeks after you receive this document. If it is not returned, we will assume that you agree to the entire contents of this specification document.

Designed by	Checked by	Approved by



Revision History

<b>Version NO.</b>	<b>DATE</b>	<b>Description</b>	<b>Remak</b>
V1.0	2020.11.08	FIRST ISSUE	



## CONTENTS

No.	ITEM	PAGE
1.	GENERAL INFORMATION	4
2.	DIAGRAM FOR LCM	5
3.	I/O CONNECTION & BLOCK DIAGRAM	6~7
4.	ABSOLUTE MAXIMUM RATINGS	8
5.	ELECTRICAL CHARACTERISTICS	8~13
6.	ELECTRO-OPTICAL CHARACTERISTICS	14~16
7.	RELIABILITY TEST CONDITIONS	17
8.	INSPECTION STANDARDS	18~19
9.	PACKAGE DRAWING	20



## 1. GENERAL INFORMATION

### 1.1 features

- 1) Structure: TFT PANNEL+IC+FPC+BL
- 2) IPS Type LCD 1280 dot-segment and 800 dot-common outputs
- 3) 16.7M Color can be selected by software
- 4) White LED back light
- 5) LVDS interface
- 6) Operation Temperature : - 20~60°C
- 7) Storage Temperature : - 30~70°C
- 8) CTP cover lens : /
- 9) CTP structure : /
- 10) LED life time: /

### 1.2 General specification

Item of	Contents	Unit
Panel Size	10.1	inch
LCD Type	a-si/TRANSMISSIVE	/
Display mode	Normally Black	/
Pixel arrangement	1280*3 (RGB)*800	Dots
Pixel pitch (W*H)	0.0565 (H) × RGB × 0.1695 (V)	um
Active Area	216.96 (H)*135.6 (V)	Mm
Module area (W*H*T)	229.5 (H)*149.1 (V)*2.48 (T)	Mm
Recommended Viewing Direction	ALL	0' clock
IC	TBD	/
Interface	LVDS	/
Luminance for LCM+TP	450	cd/m2
NTSC	50	%
Weight	TBD	g



## 2. DIAGRAM FOR LCM

由 Autodesk 教育版产品制作

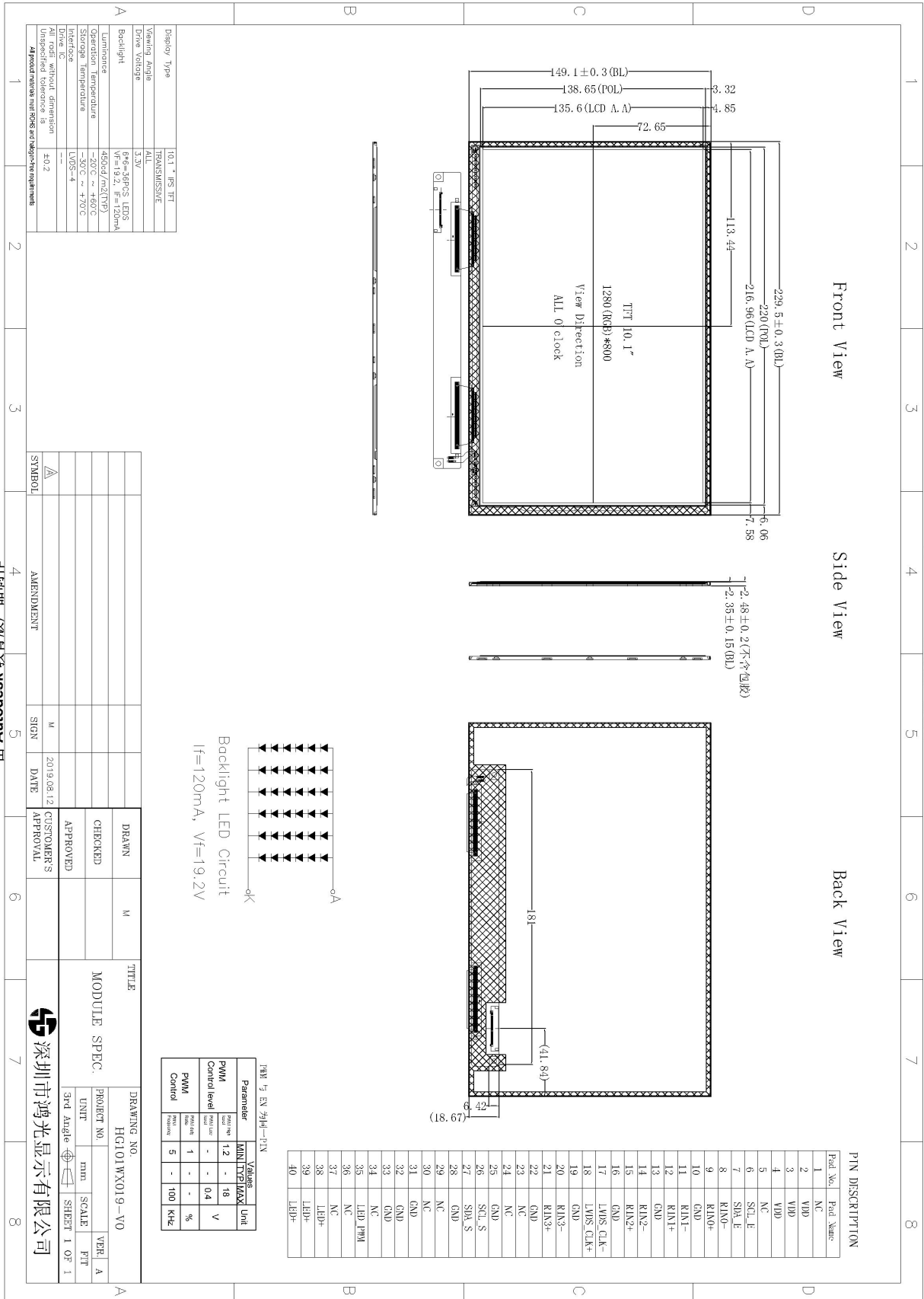

由 Autodesk 教育版产品制作

由 Autodesk 教育版产品制作

由 Autodesk 教育版产品制作



## 3. I/O CONNECTION & BLOCK DIAGRAM

### 3.1 I/O connection

LCM Pin NO.	Symbol	I/O	Description
1	NC	-	Dummy
2-4	VDD	P	Power supply for digital circuits and IO pads(3.3V)
5	NC	-	Dummy
6	SCL_E	P	Reserved for LCD manufacturer 's use , not connection
7	SDA_E	P	Reserved for LCD manufacturer 's use , not connection
8	RIN0-	P	LVDS Negative data signal (-)
9	RIN0+	I	LVDS Negative data signal (+)
10	GND	P	Power Ground
11	RIN1-	I	LVDS Negative data signal (-)
12	RIN1+	P	LVDS Negative data signal (+)
13	GND	I	Power Ground
14	RIN2-	I	LVDS Negative data signal (-)
15	RIN2+	P	LVDS Negative data signal (+)
16	GND	I	Power Ground
17	LVDS_CLK-	I	LVDS Negative data signal (-)
18	LVDS_CLK+	P	LVDS Negative data signal (+)
19	GND	I	Power Ground
20	RIN3-	I	LVDS Negative data signal (-)
21	RIN3+	P	LVDS Negative data signal (+)
22	GND	I	Power Ground
23	NC	-	Dummy
24	NC	-	Dummy
25	GND	P	Power Ground
26	SCL_S	-	Reserved for LCD manufacturer's use ,not connection
27	SDA_S	-	Reserved for LCD manufacturer's use ,not connection
28	GND	P	Power Ground
29	NC	-	Dummy
30	NC	-	Dummy
31-33	GND	P	Power Ground
34	NC	-	Dummy
35	LED_PWM	0	LED PWM signal pin
36	NC	-	Dummy
37	NC	-	Dummy
38-40	LED+	P	LED Anode

I: Input; O: Output; P: Power



## 3.2 block diagram

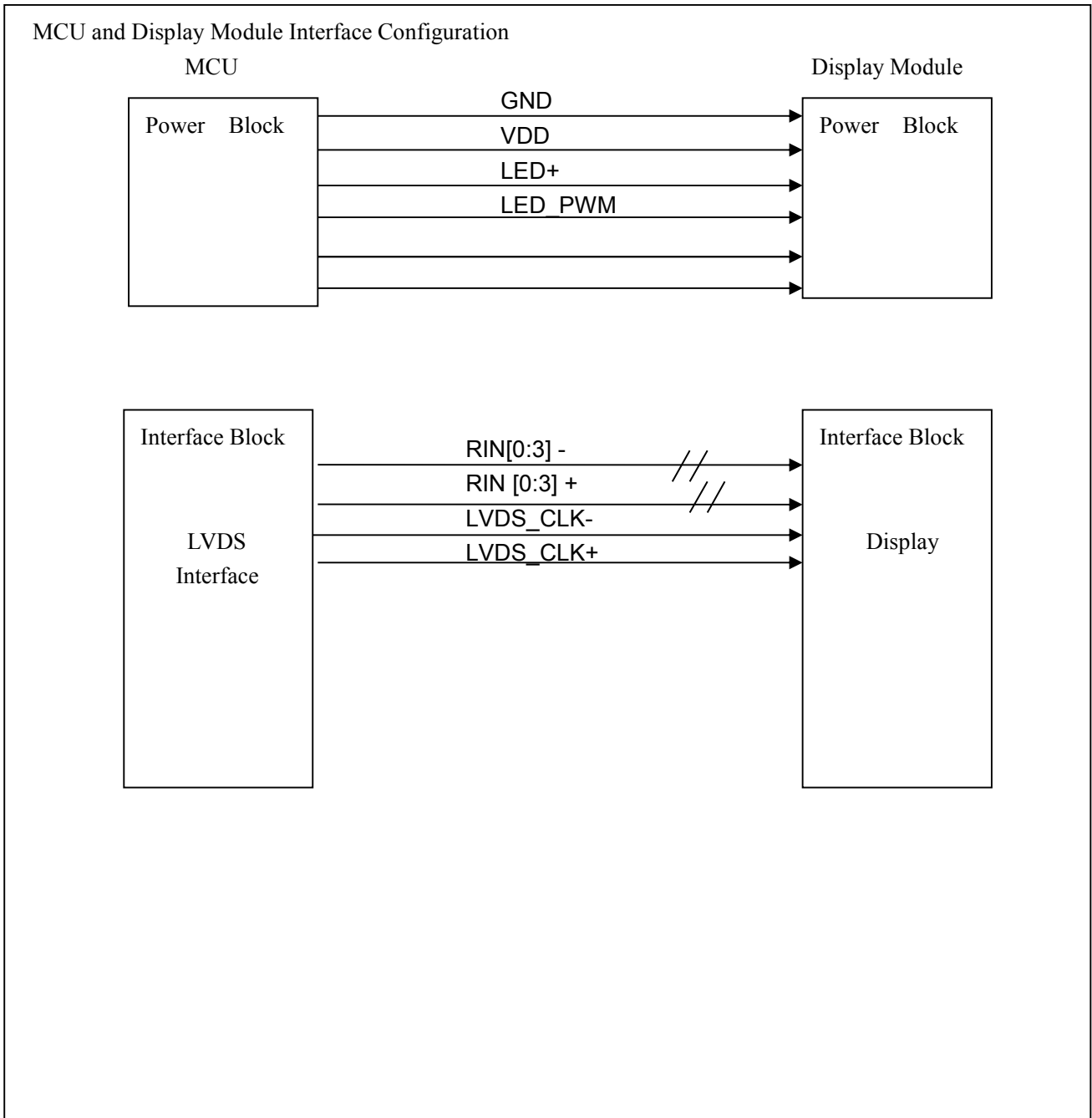



## 4. ABSOLUTE MAXIMUM RATINGS

(GND=AGND=0V)

Parameter of absolute maximum ratings 参数	Symbol 符号	Min 最小值	Max 最大值	Unit 单位
Power supply voltage1	VDD	VSS-0.3	3.6	V
Operating temperature	T <sub>op</sub>	-20	60	°C
Storage temperature	T <sub>st</sub>	-30	70	°C
Humidity	RH	-	90%(Max)/50°C	RH

Note:

1. These range above is maximum value not the actual operating temperature . Actual Operating temperature is no more than 40°C and temperature refers to the LCM surface temperature ;
2. BOE is not responsible for product problems beyond the use conditions.

## 5. ELECTRICAL CHARACTERISTICS

### 5.1 TFT LCD Module

#### LCD Module Electrical specifications

Parameter	Symbol	Values			Unit	Notes
		Min.	Typ.	Max.		
Power Supply Voltage	VDD	3.0	3.3	3.6	V	
	VRP			300	mV	Ripple
Power Supply Current	IDD	-	127	343	mA	Note 1
Power Consumption	PLCD	-	0.42	1.13	W	
Rush current		IRUSH	-	-	3.0	A
CMOS Interface	Input Voltage	VIH	2.7		3.3	V
		VIL	0		0.5	V
	Output Voltage	VOH	2.7		3.3	V
		VOL	0		0.5	V





Notes : 1. The supply voltage is measured and specified at the interface connector of LCM. The current draw and power consumption specified is for VDD=3.3V, Frame rate f V =60Hz and Clock frequency = 72.4MHz. Test Pattern of power supply current

a) Typ : Mosaic 8 x 6 Pattern(L0/L255)

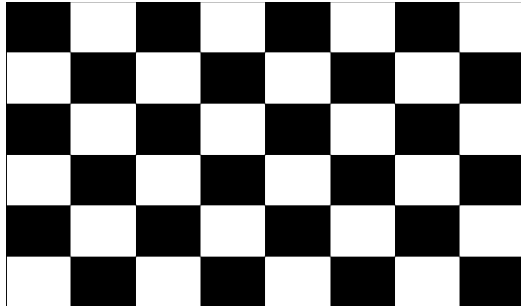

b) Max : skip subPixel(L255)



## 5.2 Back-light Unit

### LED Driving guideline specifications

Parameter	Symbol	Values			Unit	Notes	
		Min.	Typ.	Max.			
LED Power supply Input voltage	VLED	5	12	18	V	-	
Power supply voltage for Back light	VLED	-	-	21	V	-	
Power supply current for Back light	ILED	-	120	-	mA	-	
EN Control level	Backlight on	VENH	1.2	-	18	V	En logic high voltage
	Backlight off	VENL	-	-	0.4		En logic low voltage
PWM Control level	PWM High Level	VPWH	1.2	-	18	V	-
	PWM Low Level	VPWL	-	-	0.4		-
PWM Control	PWM duty Ratio		1	-	-	%	-
	PWM Frequency	FPWM	5	-	100	kHZ	-



## 5.3 Interface timing Parameter

### LVDS Timing Parameter

Parameter	Symbol	Value			Unit
		Min.	Typ.	Max.	
DCLK Frequency	Fdclk	66.3	72.4	78.9	MHz
Horizontal display area	Thd	1280			pixel
HSYNC period time	Th	1380	1440	1500	pixel
HSYNC blanking	thbp+ thfp	100	160	220	pixel
Vertical display area	Tvd	800			H
Frequency	fV	55	60	65	Hz
VSYNC period time	Tv	824	838	872	H
VSYNC blanking	Tvbp+ Tvfp	24	38	72	H

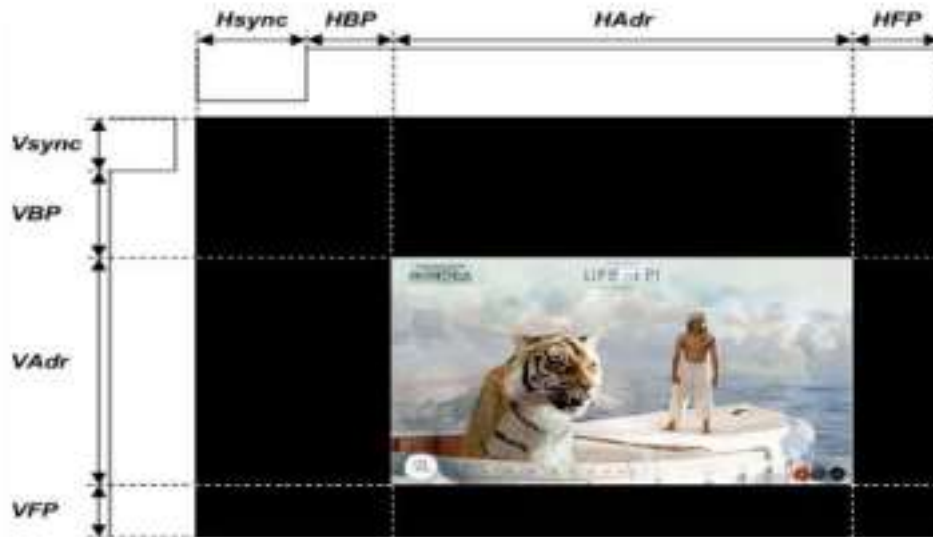



## LVDS AC Timing Specification

Item	Symbol	Min	Typ	Max	Unit	Remark
Clock frequency	RxFCLK	30	-	TBD	MHz	Refer to input timing table for each display resolution
Input data skew margin	TRSKM	500	-	-	ps	VID  = 200mV RxVCM = 1.2V RxFCLK = 81MHz
Clock high time	TLVCH	-	$4/(7 * RxFCLK)$	-	ns	
Clock low time	TLVCL	-	$3/(7 * RxFCLK)$	-	ns	
PLL wake-up time	TenPLL	-	-	150	us	
Clock frequency	RxFCLK	30	-	TBD	MHz	Refer to input timing table for each display resolution
Input data skew margin	TRSKM	500	-	-	ps	VID  = 200mV RxVCM = 1.2V RxFCLK = 81MHz
Clock high time	TLVCH	-	$4/(7 * RxFCLK)$	-	ns	
Clock low time	TLVCL	-	$3/(7 * RxFCLK)$	-	ns	

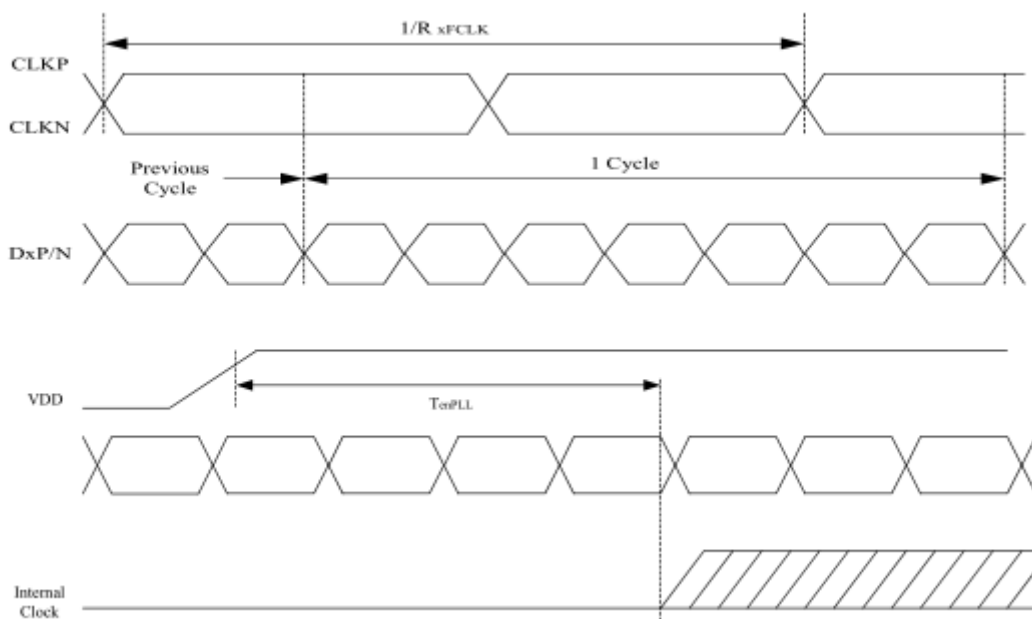

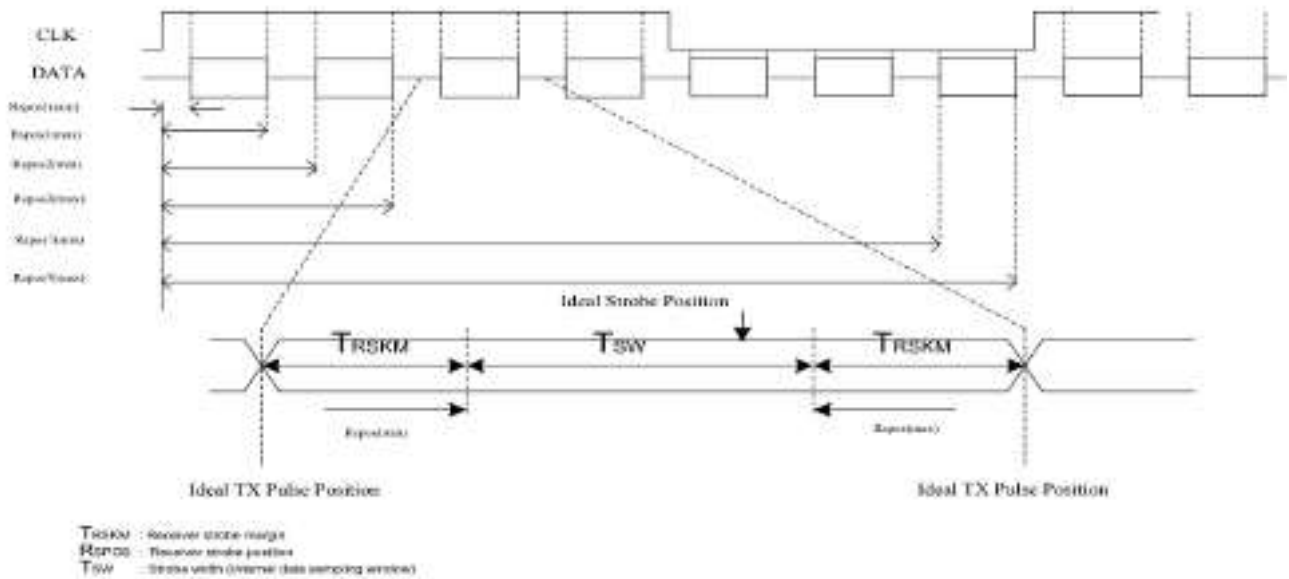

## LVDS DC Timing Specification

Parameter	Symbol	Min.	Typ.	Max.	Unit	Condition
Differential input high threshold voltage	RXVTH	+0.1	0.2	0.3	V	RXVCM=1.2V
Differential input low threshold voltage	RXVTL	-0.3	-0.2	-0.1	V	
Input voltage range (single-ended)	RXVIN	0.7	-	1.7	V	
Differential input common mode voltage	RXVCM	1	1.2	1.4	V	VID =0.2
Differential input impedance	ZID	80	100	125	ohm	
Differential input voltage	VID	0.2	-	0.6	V	
Differential input leakage current	ILCLVDS	-10	-	+10	uA	
LVDS Digital Operating Current	IVDDMIP1	-	15	20	mA	FDCLK=80MHz, VDD=3.3V, Input pattern: 55h->Aah->55h->Aah
LVDS Digital Stand-by Current	ISTMPI1	-	-	250	uA	Clock & all Functions are stopped



## Single-end Signals

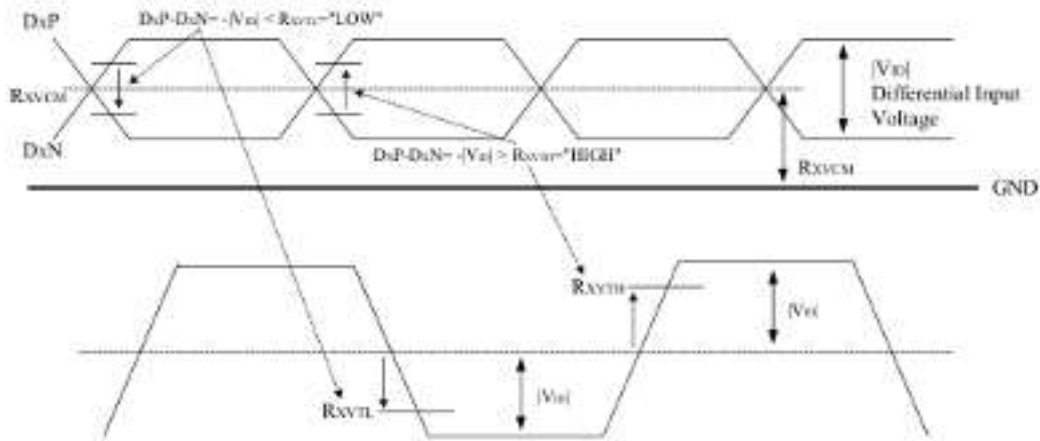

## 5.4 Power Sequence

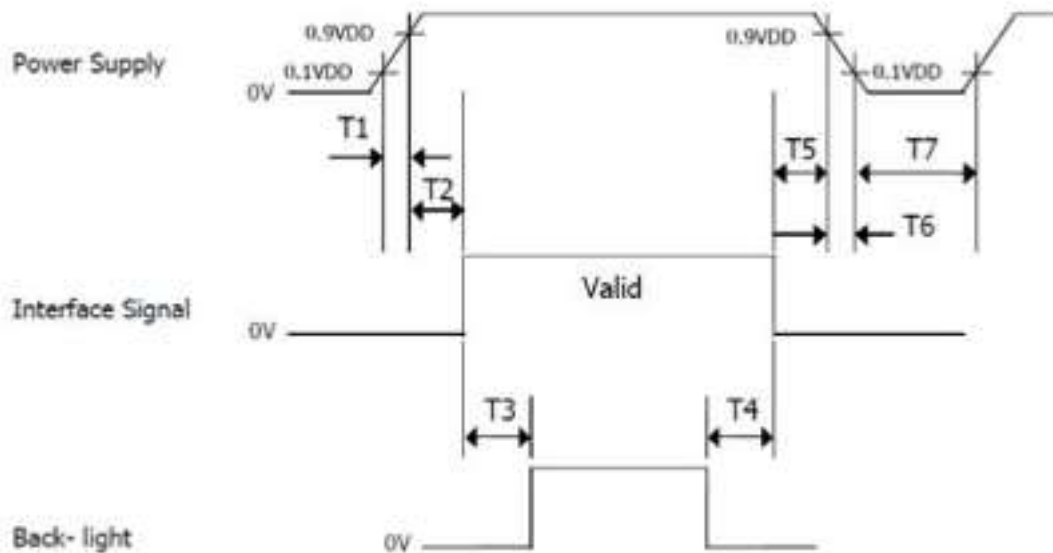

Sequence Table

Parameter	Values			Units
	Min	Typ	Max	
T1	0	-	10	ms
T2	0	-	50	ms
T3	200	-	-	ms
T4	500	-	-	ms
T5	0	-	50	ms
T6	0	-	10	ms
T7	500	-	-	ms



## 6. ELECTRO-OPTICAL CHARACTERISTICS

Parameter		Symbol	Condition	Min.	Typ.	Max.	Unit	Note
Contrast Ratio (Center point)		C/R	-	-	1000	-	-	Note(1)
Luminance uniformity		U <sub>w</sub>	θ = 0. Normal viewing angle B/L On Note(1)	75	80	-	%	Note(2)
Response Time		Tr + Tf		-	30	35	ms	Note(3)
Color Chromaticity (CIE 1931)	White	W <sub>x</sub>			0.30			参考 值
		W <sub>y</sub>		0.32				
	Red	R <sub>x</sub>		0.618				
		R <sub>y</sub>		0.329				
	Green	G <sub>x</sub>	-0.02	0.283	+0.02			
		G <sub>y</sub>		0.542				
	Blue	B <sub>x</sub>		0.139				
		B <sub>y</sub>		0.164				
Viewing Angle	Hor.	∅ 3R	C/R≥10		80	-	Deg	Note(4)
		∅ 9L			80	-		
	Ver.	∅ 12U			80	-		
		∅ 6D		-	80	-		



Note1 Definition of Contrast Ratio (CR):

$$\text{Contrast ratio (CR)} = \frac{\text{Luminance measured when LCD on the "White" state}}{\text{Luminance measured when LCD on the "Black" state}}$$

Note2: Definition of Luminance Uniformity: Active area is divided into 9 measuring areas (Shown in below), every measuring point is placed at the center of each measuring area.

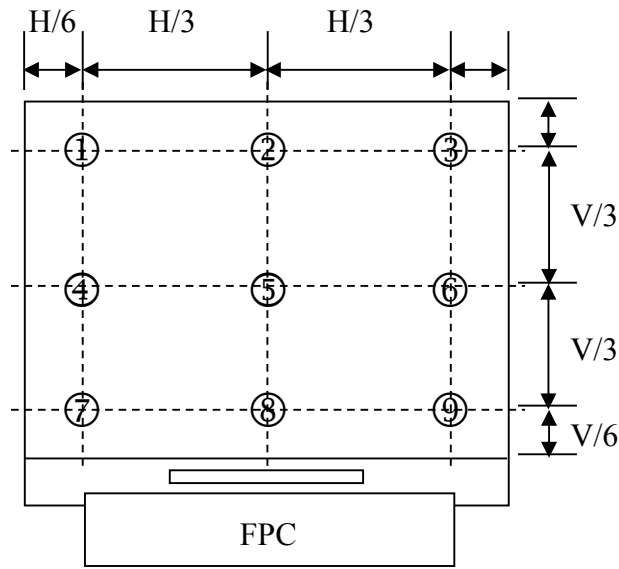

The spot locations for luminance measurement

$$\text{Luminance Uniformity} = \frac{B_{\min}}{B_{\max}} \times 100\%$$

$B_{\max}$ : The measured maximum luminance of all measurement position.

$B_{\min}$ : The measured minimum luminance of all measurement position.

Note 3: Definition of Response time: Sum of  $T_r$  and  $T_f$

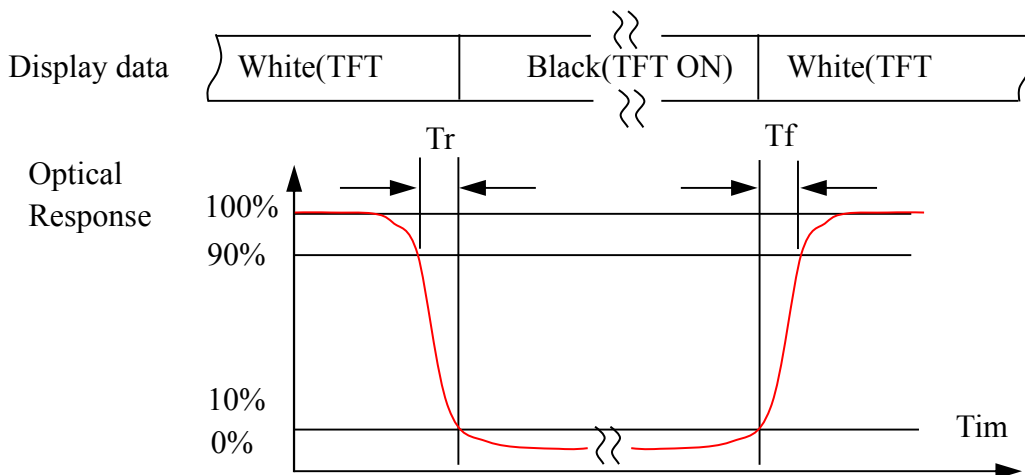



Note4. Definition of Viewing Angle: The viewing angle range that the  $CR \geq 10$

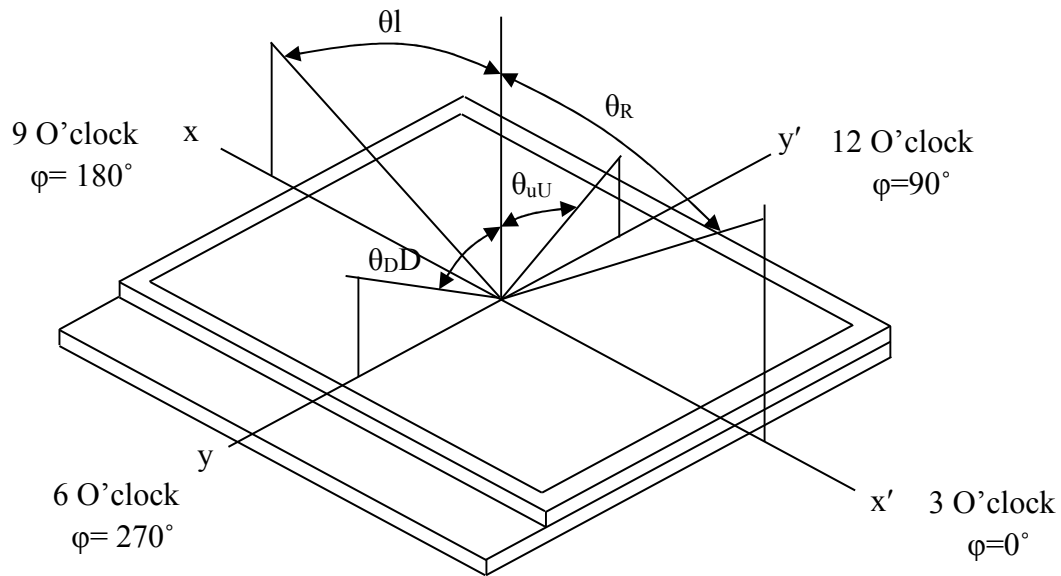

Note 5: Definition of Color Chromaticity (CIE 1931)

Color coordinate of white & red, green, blue at center point.





## 7. RELIABILITY TEST CONDITIONS

No	Test Item	Test Condition	STANDARD
1	High Temperature Storage	+70°C / 96Hours	1. Functional test is OK. Missing Segment, short, unclear segment, on-display, display abnormally and liquid crystal leak are un-allowed. 2. No low temperature bubbles, end seal loose and fall, frame rainbow.
2	Low Temperature Storage	-30°C / 96Hours	
3	High Temperature Operating	+60°C / 96Hours	
4	Low Temperature Operating	-20°C / 96Hours	
5	Thermal and cold shock	0°C↔+50°C x 10cycles (30min) (5min) (30min)	
6	Operate at High Temperature and Humidity	50°C x 90%RH / 24H	
7	Vibration Test	Frequency: 10Hz~55Hz~10Hz Amplitude:1.5mm, 2 hours for each direction of X, Y, Z	1. Function test is OK. 2. No glass crack, chipped glass, end seal loose and fall, epoxy frame crack and so on. 3. No structure loose and fall.
8	Dropping test	Drop to the ground from 1m height, 1 corner, 3 edges, 6 surfaces.	
9	ESD test	Contact: ±6KV Air: ±10KV 150PF/330Ω,5Points/pa nel,5times	The test results shall be subject to the whole machine test.

### NOTE:

1. The reliability items will be fully performed in new sample qualification,
2. The reliability status will be tested as monitor during mass production. Individual reliability test shall be performed by lot , Moreover, the individual reliability item shall be decided according to reliability plan.
3. All samples are inspected after keeping in the room with normal temperature and humidity for 2 hours or above.
4. Vibration test: It is not necessary to test for those products without assembly frame , backlight , PCB and so on.
5. Dropping test : It is necessary for affirming new package.
6. For the high temperature and high humidity test, pure water of over 10 MΩ.cm should be used.
7. Each test item applies for test LCM only once .Then tested LCM cannot be used again in any other test item.
8. The quantity of LCM examination for each test item is 5pcs to 10pcs.



## 8. INSPECTION STANDARDS

### 8.1 AQL Sampling inspection standard

使用 GB/T 2828-2003 一般 II 水平, 采用正常检查一次抽样方式; 具体抽检方式参照《成品检验管理程序》、《抽样管理规范》

缺陷区分	AQL 允收水准
严重缺陷	0 收 1 退
重缺	0.4
轻缺	1.0

### 8.2 Inspect the condition

8.2.1 在 20—40W 日光灯的照明条件下, 样品离检查者眼睛约 30cm 处进行检查。检验方向以垂直线前后左右 45° (以时钟 3 点、6 点、9 点、12 点)

8.2.2 检验者视力需达到标准视力 1.0 以上。

8.2.3 检验者需戴静电手环、两手八个手指套。

8.2.4 外观检验者以目视检查或以菲林对比卡比对。

8.2.5 电性测试使用电测测架, 主板, 电源线及单片机。

8.2.6 若标准与规格书不符时, 以产品发行之规格书特殊检验规格、工程变更为准

8.2.7 辉色度检测请参照样品, 检测方法依照辉色度检验标准。

8.2.8 电测检验环境: 照度为 200LUX 以下, 外观检验环境: 照度为 600LUX-1000LUX, 检验时间: 1 秒-3 秒。

8.2.9 检验工具: 电测测架, 主板, 电源线及单片机, 菲林对比卡, 游标卡尺, 放大镜, 实体显微镜 (必要时) 等等。

### 8.3 Judgment criterion

小尺寸点、线判定标准: (6.2 寸以内)

1	点状缺陷 (磨伤、异物、针孔、凹痕、缺膜、气泡、白点、彩点、脏点)		判定 (A/B/C 区)	$D \leq 0.10$ , 忽略不计, 但密集型不允许	MI	OK
				$0.1 < D \leq 0.15$ , $ds \geq 10$		$N \leq 2$
				$0.15 < D \leq 0.2$ , $ds \geq 10$		$N \leq 1$
				LCD 亮点: $0.15 < D$		$N \leq 1$
				$D > 0.2$		NG
			判定 (D 区)	同背面丝印油墨区杂质判定标准		
			注: 1) D 区的点状缺陷需在不影响 CTP 功能、客户组装及整机的外观的情况下, 判定 OK		MI	
2	线状缺陷 (磨伤、无感划伤、毛屑、纤维等)		判定 (A/B/C 区)	$W \leq 0.03mm$ , $L \leq 3mm$ , $ds \geq 10$	MI	$N \leq 2$
				$0.03mm < W \leq 0.05mm$ , $L \leq 3mm$ , $ds \geq 10$		$N \leq 1$
				$W > 0.05mm$ 或 $L > 3mm$		NG



中尺寸点、线判定标准：(6.2 8 寸以内)

1	点状缺陷 (磨伤、异物、针孔、凹痕、缺膜、气泡、白点、彩点、脏点)		判定(A/B/C区)	$D \leq 0.10$ , 忽略不计, 但密集型不允许 $0.15 < D \leq 0.25$ , $ds \geq 10$ $0.25 < D \leq 3$ , $ds \geq 10$ LCD 亮点: $0.2 < D$ $D > 0.3$	MI	OK
			判定(D区)	同背面丝印油墨区杂质判定标准		N $\leq$ 2 N $\leq$ 1 N $\leq$ 1 NG
			注: 1) D区的点状缺陷需在不影响CTP功能、客户组装及整机的外观的情况下, 判定OK		MI	
2	线状缺陷 (磨伤、无感划伤、毛屑、纤维等)		判定(A/B/C区)	$W \leq 0.03mm$ , $L \leq 3mm$ , $ds \geq 10$ $0.03mm < W \leq 0.05mm$ , $L \leq 3mm$ , $ds \geq 10$	MI	N $\leq$ 2
				$W > 0.05mm$ 或 $L > 3mm$		N $\leq$ 1
						NG

大尺寸点、线判定标准：(8.1~13.3寸以内)

1	点状缺陷 (磨伤、异物、针孔、凹痕、缺膜、气泡、白点、彩点、脏点)		判定(A/B/C区)	$D \leq 0.1$ , 忽略不计, 但密集型不允许 $0.15 < D \leq 0.3$ , $ds \geq 10$ $0.3 < D \leq 0.35$ , $ds \geq 10$ LCD 亮点: $0.25 < D$ $D > 0.35$	MI	OK
			判定(D区)	同背面丝印油墨区杂质判定标准		N $\leq$ 2 N $\leq$ 1 N $\leq$ 1 NG
			注: 1) D区的点状缺陷需在不影响CTP功能、客户组装及整机的外观的情况下, 判定OK		MI	
2	线状缺陷 (磨伤、无感划伤、毛屑、纤维等)		判定(A/B/C区)	$W \leq 0.05mm$ , $L \leq 5mm$ , $ds \geq 10$ $0.05mm < W \leq 0.07mm$ , $L \leq 5mm$ , $ds \geq 10$	MI	N $\leq$ 2
				$W > 0.07mm$ 或 $L > 5mm$		N $\leq$ 1
						NG



9. PACKAGE DRAWING

