



SPECIFICATION FOR TFT LCD MODULE

CUSTOMER : _____

CUSTOMER MODULE : _____

HG MODEL : _____ HG173FH002-V0

Preliminary Specification

Final Specification

Customer Confirmation column:

Approved by : _____ Dept. : _____ Data : _____

Please return one of the copies of the specification with your signature to us within two weeks after you receive this document. If it is not returned, we will assume that you agree to the entire contents of this specification document.

Designed by	Checked by	Approved by



Contents

No.	Items	Page
1.0	General Description	3
2.0	Absolute Maximum Ratings	5
3.0	Electrical Specifications	6
4.0	Optical Specifications	8
5.0	Interface Connection	13
6.0	Signal Timing Specification	18
7.0	Input Signals, Display Colors & Gray Scale of Colors	20
8.0	Power Sequence	21
9.0	Connector Description	22
10.0	Mechanical Characteristics	23
11.0	Reliability Test	24
12.0	Handling & Cautions	24
13.0	Packing Information	25
14.0	Mechanical Outline Dimension	26
15.0	EDID Table	27



1.0 GENERAL DESCRIPTION

1.1 Introduction

HG173FH002-V0 is a color active matrix TFT LCD module using amorphous silicon TFT's (Thin Film Transistors) as an active switching devices. This module has a 17.3 inch diagonally measured active area with Full-HD resolutions (1920 horizontal by 1080 vertical pixel array). Each pixel is divided into RED, GREEN, BLUE dots which are arranged in vertical stripe and this module can display 16.7M(8bit) colors and color gamut 45%. The TFT-LCD panel used for this module is a low reflection and higher color type. Therefore, this module is suitable for Notebook PC. The LED driver for back-light driving is built in this model.

All input signals are eDP1.2 interface compatible.

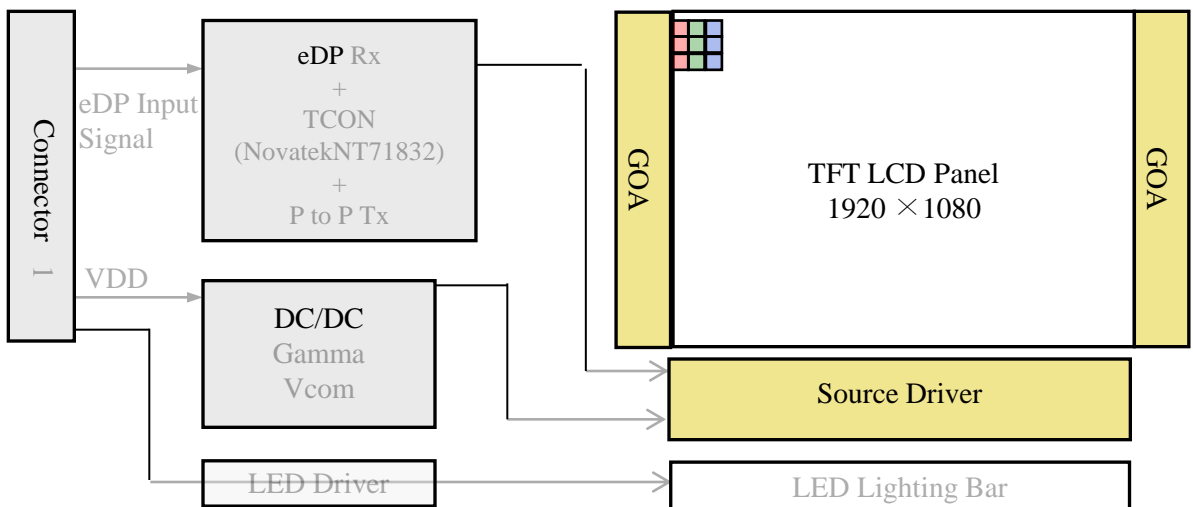

Figure 1. Drive Architecture

1.2 Features

- 2 lane eDP interface with 2.7Gbps link rates
- Thin and light weight
- 16.7M(8bit) color depth, color gamut 45%
- Single LED lighting bar (Bottom side/Horizontal Direction)
- Data enable signal mode
- Side mounting frame
- Green product (RoHS & Halogen free product)
- On board LED driving circuit
- Low driving voltage and low power consumption
- On board EDID chip



1.3 Application

- Notebook PC (Wide type)

1.4 General Specification

The followings are general specifications at the model HG173FH002-V0 (listed in Table 1)

<Table 1. General Specifications>

Parameter	Specification	Unit	Remarks
Active area	381.888(H) × 214.812(V)	mm	
Number of pixels	1920 (H) × 1080 (V)	pixels	
Pixel pitch	198.9(H) × 198.9(V)	um	
Pixel arrangement	RGB Vertical stripe		
Display colors	16.7M(8bit)		
Color gamut	45%		
Display mode	Normally Black		
Dimensional outline	389.95(H) ± 0.3 × 227.07(V) ± 3.0 (W PCB)	mm	
Weight	500(max)	g	
Electrical Interface	eDP1.2 (eDP w/o PSR)		
Surface treatment	Anti-Glare		
Surface hardness	3H		
Back-light	Bottom edge side, 1-LED lighting bar type		Note 1
Power consumption	P_D : 0.96(Typ)	W	@Mosaic
	P_{BL} : 9.6(Typ)	W	
	P_{Total} : 10.56(TYP)	W	@Mosaic

Notes : 1LED Lighting Bar (80*LED Array)



2.0 ABSOLUTE MAXIMUM RATINGS

The followings are maximum values which, if exceed, may cause faulty operation or damage to the unit. The operational and non-operational maximum voltage and current values are listed in Table 2.

< Table 2. Absolute Maximum Ratings >

Ta=25+/-2°C

Parameter	Symbol	Min.	Max.	Unit	Remarks
Power Supply Voltage	V _{DD}	-0.3	4.0	V	Note 1
Logic Supply Voltage	V _{IN}	V _{SS} -0.3	V _{DD} +0.3	V	
Operating Temperature	T _{OP}	-20	+70	°C	Note 2
Storage Temperature	T _{ST}	-30	+70	°C	

Notes :

1. Permanent damage to the device may occur if maximum values are exceeded functional operation should be restricted to the condition described under normal operating conditions.
2. Temperature and relative humidity range are shown in the figure below.
95 % RH Max. (40 °C ≥ Ta) Maximum wet - bulb temperature at 39 °C or less. (Ta > 40 °C) No condensation.

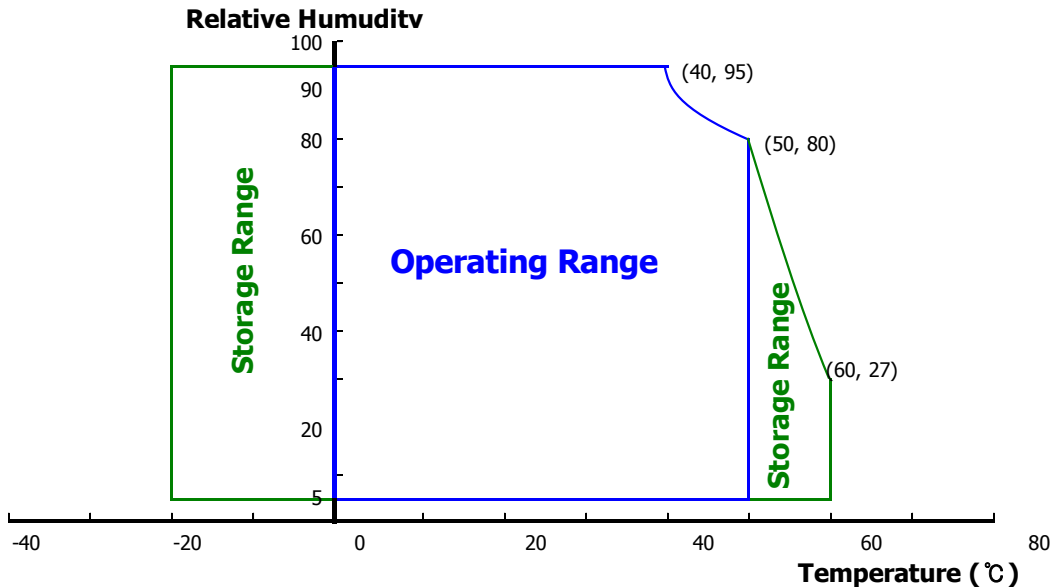

Figure 2. Temperature and Relative Humidity Range



3.0 ELECTRICAL SPECIFICATIONS

3.1 Electrical Specifications

< Table 3. Electrical Specifications >

Ta=25+/-2°C

Parameter		Min.	Typ.	Max.	Unit	Remarks
Power Supply Voltage	V _{DD}	3.0	3.3	3.6	V	Note 1
Permissible Input Ripple Voltage	V _{RF}	-10%*V _{DD}	-	10%*V _{DD}	V	Note 4
Power Supply Current	I _{DD}	-	320	-	mA	Note 1
Power Supply Inrush Current	I _{inrush}	-	-	1.5	A	Note3
Power Consumption	P _D	-	0.96	1.35	W	Note 1
	P _{BL}	-	9.6	-	W	Note 2
	P _{total}	-	10.56	-	W	Note 1

Notes :

1. The supply voltage is measured and specified at the interface connector of LCM.

The current draw and power consumption specified is for 3.3V at 25 °C.

a) Typ : Mosaic pattern 8*8

b) Max : R/G/B patterns

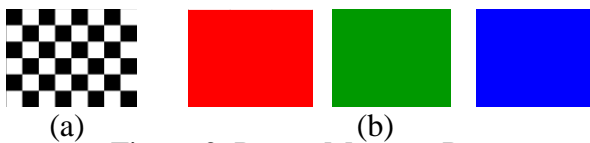

Figure 3. Power Measure Patterns

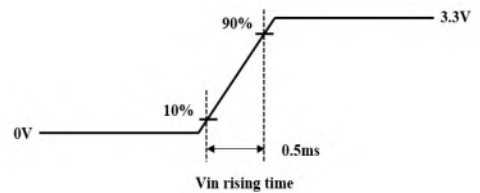

Figure 4. Inrush Measure Condition

2. Calculated value for reference (V_{LED} × I_{LED})

3. Measure condition (Figure 4)

4. Input voltage range:3.0~3.6V.Test condition: Oscilloscope bandwidth 20MHz, AC coupling.



3.2 Backlight Unit

< Table 4. LED Driving Guideline Specifications >

Ta=25+/-2°C

Parameter		Min.	Typ.	Max.	Unit	Remarks
LED Forward Voltage	V_F	-	6.0	-	V	
LED Forward Current	I_F	-	20	-	mA	
LED Power Consumption	P_{LED}	-	9.6	-	W	Note 1
LED Life-Time	N/A	15,000	-	-	Hour	$I_f = 22.5mA$
Power Supply Voltage for LED Driver	V_{LED}	-	-	-	V	
Power Supply Voltage for LED Driver Inrush	Iled inrush	-	-	-	A	Note 4
EN Control Level	Backlight On	-	-	-	V	
	Backlight Off	-	-	-	V	
PWM Control Level	High Level	-	-	-	V	
	Low Level	-	-	-	V	
PWM Control Frequency	F_{PWM}	-	-	-	Hz	
Duty Ratio		-	-	-	%	Note 3

Notes :

1. Power supply voltage 24V for LED driver
 . Calculator value for reference $I_F \times V_F \times 80 / \text{driver efficiency} = P_{LED}$
2. The LED life-time define as the estimated time to 50% degradation of initial luminous.
3. 5% duty cycle is achievable with a dimming frequency less than 1KHz.
4. Measure condition (Figure 5)

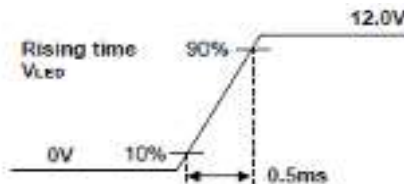

Figure 5. Inrush Measure Condition



4.0 OPTICAL SPECIFICATION

4.1 Overview

The test of optical specifications shall be measured in a dark room (ambient luminance ≤ 1 lux and temperature = $25 \pm 2^\circ\text{C}$) with the equipment of luminance meter system (Goniometer system and TOPCON BM-5) and test unit shall be located at an approximate distance 50cm from the LCD surface at a viewing angle of θ and Φ equal to 0° . We refer to $\theta=0$ ($=\theta_3$) as the 3 o'clock direction (the "right"), $\theta=90$ ($=\theta_{12}$) as the 12 o'clock direction ("upward"), $\theta=180$ ($=\theta_9$) as the 9 o'clock direction ("left") and $\theta=270$ ($=\theta_6$) as the 6 o'clock direction ("bottom"). While scanning θ and/or Φ , the center of the measuring spot on the display surface shall stay fixed. The backlight should be operating for 30 minutes prior to measurement. VDD shall be $3.3 \pm 0.3\text{V}$ at 25°C . Optimum viewing angle direction is 6 o'clock.

4.2 Optical Specifications

<Table 5. Optical Specifications>

Parameter		Symbol	Condition	Min.	Typ.	Max.	Unit	Remark
Viewing Angle Range	Horizontal	θ_3	CR > 10	80	85	-	Deg.	Note 1
		θ_9		80	85	-	Deg.	
	Vertical	θ_{12}		80	85	-	Deg.	
		θ_6		80	85	-	Deg.	
Luminance Contrast Ratio		CR	$\theta = 0^\circ$	640	800	-		Note 2
Luminance of White	5 Points	Y_w	$\theta = 0^\circ$ $I_{LED} = 22.5\text{mA}$	800	1000	-	cd/m ²	Note 3
White Luminance Uniformity	5 Points	ΔY_5		80	-	-		Note 4
	13 Points	ΔY_{13}		65	-	-		
White Chromaticity		W_x	$\theta = 0^\circ$	0.283	0.313	0.343		Note 5
		W_y		0.299	0.329	0.359		
Reproduction of Color	Red	R_x	$\theta = 0^\circ$	-0.030	0.640	+0.030		
		R_y			0.330			
	Green	G_x			0.300			
		G_y			0.600			
	Blue	B_x			0.150			
		B_y			0.060			
Color Gamut				40	45	-	%	sRGB
Response Time		T_{RT}	$T_a = 25^\circ\text{C}$ $\theta = 0^\circ$	-	16	25	ms	Note 6
Cross Talk		CT	$\theta = 0^\circ$	-	-	2.0	%	Note 7



Notes :

1. Viewing angle is the angle at which the contrast ratio is greater than 10. The viewing angles are determined for the horizontal or 3, 9 o'clock direction and the vertical or 6, 12 o'clock direction with respect to the optical axis which is normal to the LCD surface (see Figure 7).
2. Contrast measurements shall be made at viewing angle of $\Theta=0$ and at the center of the LCD surface. Luminance shall be measured with all pixels in the view field set first to white, then to the dark (black) state . (see Figure 7) Luminance Contrast Ratio (CR) is defined mathematically.

$$CR = \frac{\text{Luminance when displaying a white raster}}{\text{Luminance when displaying a black raster}}$$

3. Center Luminance of white is defined as luminance values of 5 point average across the LCD surface. Luminance shall be measured with all pixels in the view field set first to white. This measurement shall be taken at the locations shown in Figure 8 for a total of the measurements per display.
4. The White luminance uniformity on LCD surface is then expressed as : $\Delta Y = \text{Minimum Luminance of 5(or 13) points} / \text{Maximum Luminance of 5(or 13) points.}$ (see Figure 8 and Figure 9).
5. The color chromaticity coordinates specified in Table 5 shall be calculated from the spectral data measured with all pixels first in red, green, blue and white. Measurements shall be made at the center of the panel.
6. The electro-optical response time measurements shall be made as Figure 10 by switching the “data” input signal ON and OFF. The times needed for the luminance to change from 90% to 10% is T_f , and 10% to 90% is T_r .
7. Cross-Talk of one area of the LCD surface by another shall be measured by comparing the luminance (YA) of a 25mm diameter area, with all display pixels set to a gray level, to the luminance (YB) of that same area when any adjacent area is driven dark. (See Figure 11).



4.3 Optical Measurements

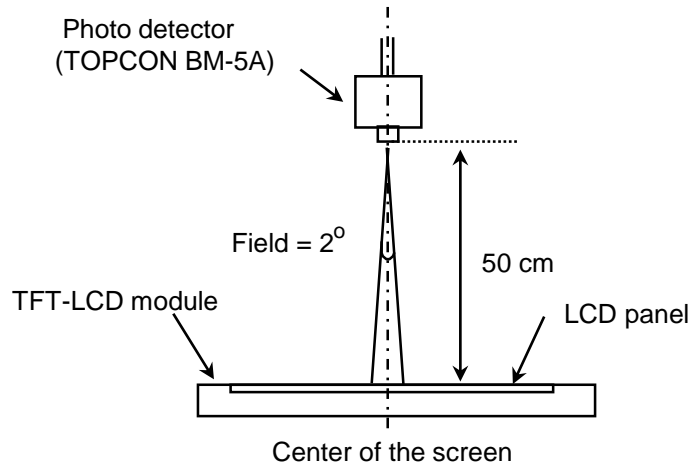

Optical characteristics measurement setup

Figure 7. Measurement Set Up

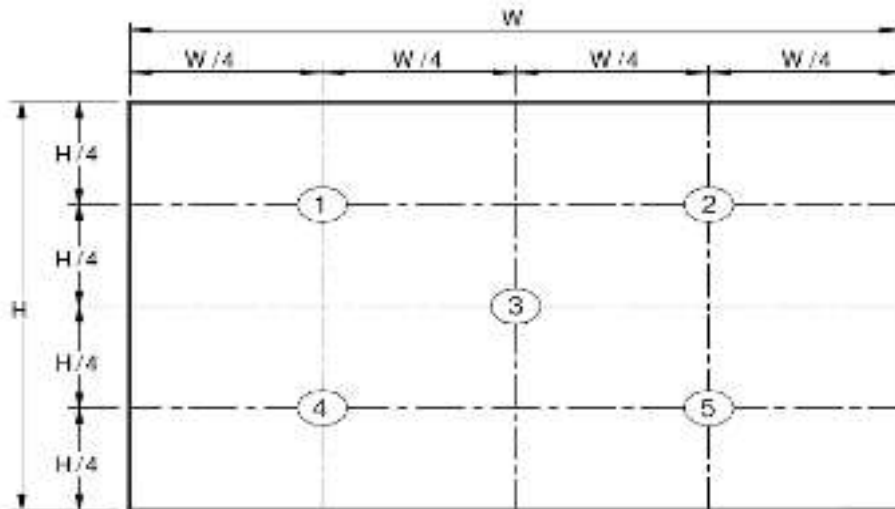

Figure 8. White Luminance and Uniformity Measurement Locations (5 points)

Center Luminance of white is defined as luminance values of center 5 points across the LCD surface. Luminance shall be measured with all pixels in the view field set first to white. This measurement shall be taken at the locations shown in Figure 7 for a total of the measurements per display.

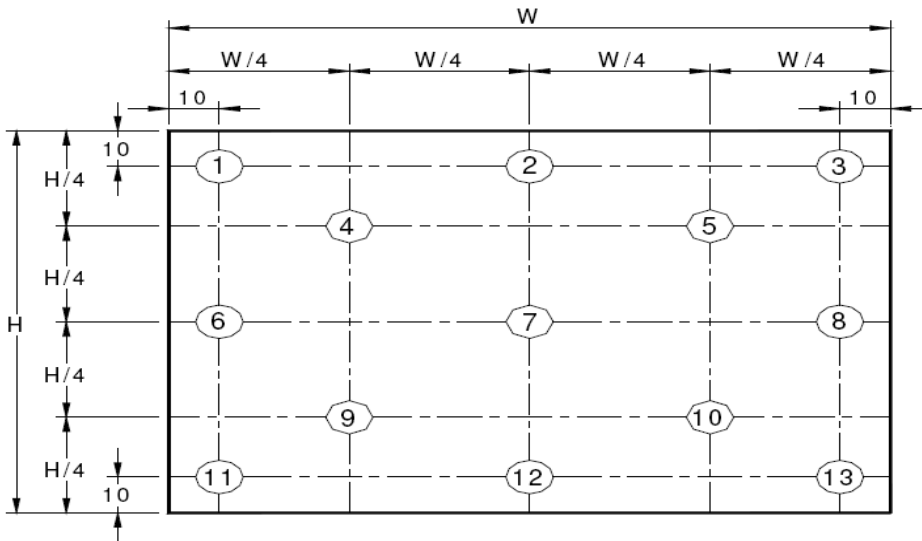

Figure 9. Uniformity Measurement Locations (13 points)

The White luminance uniformity on LCD surface is then expressed as : $\Delta Y5 = \text{Minimum Luminance of five points} / \text{Maximum Luminance of five points}$ (see Figure 8) , $\Delta Y13 = \text{Minimum Luminance of 13 points} / \text{Maximum Luminance of 13 points}$ (see Figure 9).

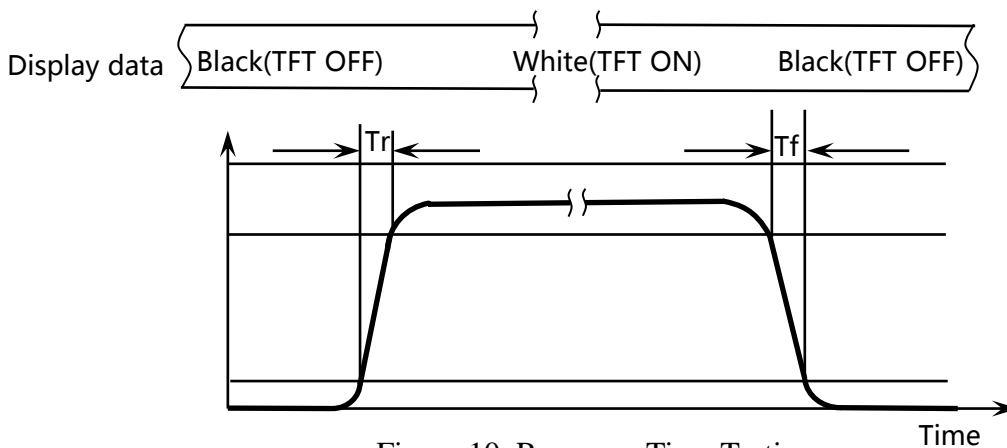
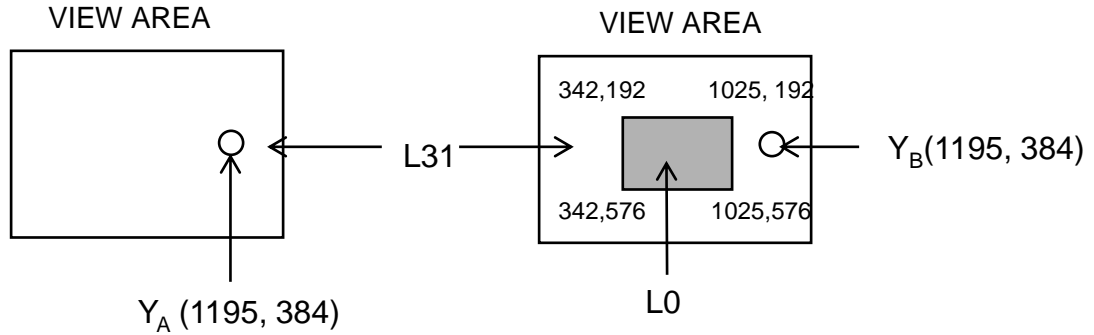

Figure 10. Response Time Testing

The electro-optical response time measurements shall be made as shown in Figure 10 by switching the “data” input signal ON and OFF. Tr: The luminance to change from 90% to 10% ,Tf: The luminance to change from 10% to 90% .

The test system : PR810



$$\text{Cross-Talk (\%)} = \left| \frac{Y_B - Y_A}{Y_A} \right| \times 100$$

Figure 11. Cross Talk Modulation Test Description

Where:

Y_A = Initial luminance of measured area (cd/m²)

Y_B = Subsequent luminance of measured area (cd/m²)

The location measured will be exactly the same in both patterns

Cross-Talk of one area of the LCD surface by another shall be measured by comparing the luminance (Y_A) of a 25mm diameter area, with all display pixels set to a gray level, to the luminance (Y_B) of that same area when any adjacent area is driven dark Refer to Figure 11)

The test system: PR730



5.0 INTERFACE CONNECTION

5.1 Electrical Interface Connection

The electronics interface connector is MSAK24025P30.

The connector interface pin assignments are listed in Table 6.

<Table 6. Pin Assignments for the Interface Connector>

Terminal	Symbol	Functions
Pin No.	Symbol	Description
1	NC	No Connect
2	H_GND	Ground
3	LANE1_N	eDP RX Channel 1 Negative
4	LANE1_P	eDP RX Channel 1 Positive
5	H_GND	Ground
6	LANE0_N	eDP RX Channel 0 Negative
7	LANE0_P	eDP RX Channel 0 Positive
8	H_GND	Ground
9	AUX_CH_P	eDP AUX CH Positive
10	AUX_CH_N	eDP AUX CH Negative
11	H_GND	Ground
12	VCC	LCD logic and driver power
13	VCC	LCD logic and driver power
14	LCD Self Test	LCD Panel Self Test Enable (Optional)
15	GND	LCD logic and driver ground
16	GND	LCD logic and driver ground
17	HPD	HPD signal pin
18	NC Reserved	No Connect
19	NC Reserved	No Connect
20	NC Reserved	No Connect



5.0 INTERFACE CONNECTION

5.1 Electrical Interface Connection

The electronics interface connector is MSAK24025P30.

The connector interface pin assignments are listed in Table 6.

<Table 6. Pin Assignments for the Interface Connector>

Terminal	Symbol	Functions
Pin No.	Symbol	Description
21	NC Reserved	No Connect
22	NC Reserved	No Connect
23	NC ReservedM	No Connect
24	NC Reserved	No Connect
25	NC Reserved	No Connect
26	NC Reserved	No Connect
27	NC Reserved	No Connect
28	NC Reserved	No Connect
29	NC Reserved	No Connect
30	NC Reserved	No Connect



5.2 eDP Interface

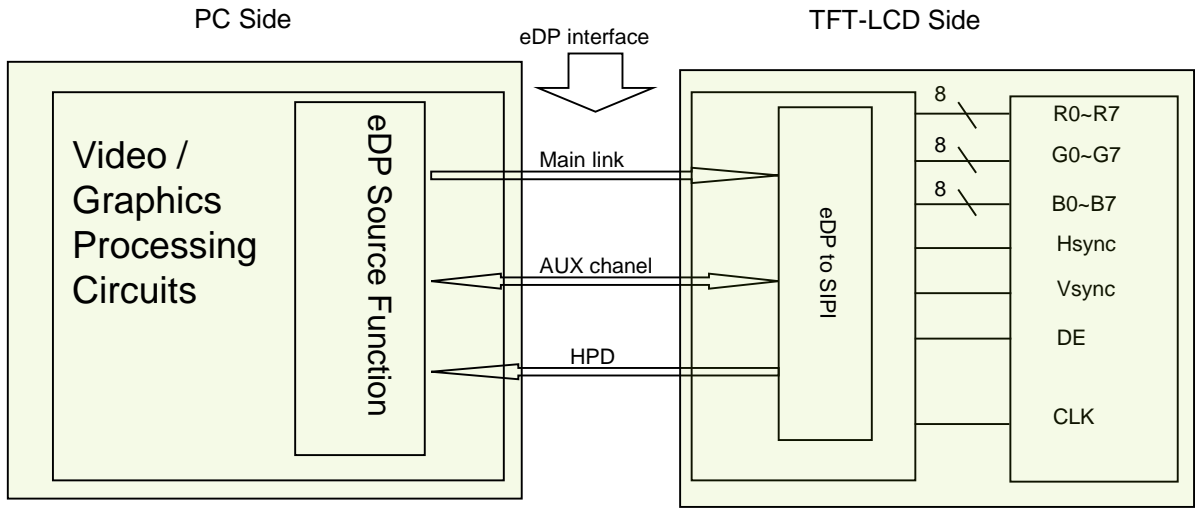

Figure 12. eDP Interface Architecture

Note:

Transmitter DP689 or equivalent.

Transmitter is not contained in module.

5.3.eDP Input signal

Lane 0	Lane 1
R0-7:0	R1-7:0
G0-7:0	G1-7:0
B0-7:0	B1-7:0
R4-7:0	R5-7:0
G4-7:0	G5-7:0
B4-7:0	B5-7:0
R8-7:0	R9-7:0
G8-7:0	G9-7:0
B8-7:0	B9-7:0



5.3 Data Input Format

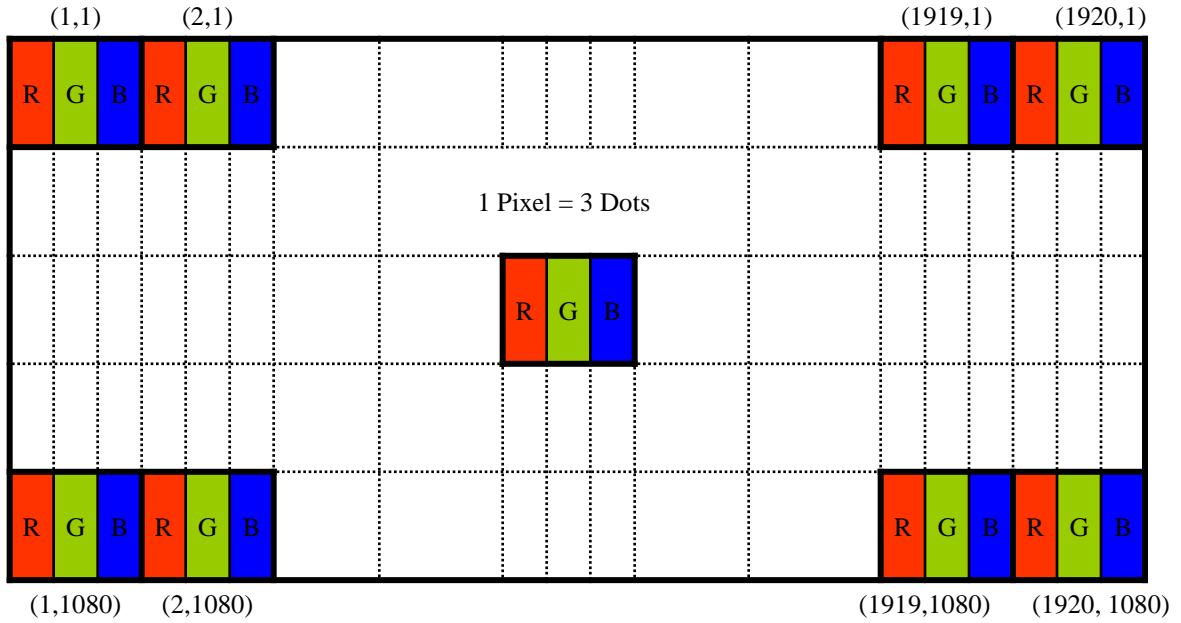

Figure 13. Display Position of Input Data (V-H)



5.4 Back-light & LCM Interface Connection

BLU Interface Connector: BH3.5

<Table 7. Pin Assignments for the BLU Connector>

Pin No.	Symbol	Description	Pin No.	Symbol	Description
1	LED	LED anode connection	2	LED	LED cathode connection



6.0 SIGNAL TIMING SPECIFICATION

6.1 The HG173FH002-V0 Is Operated By The DE Only

< Table 8. Signal Timing Specification >

Item		Symbols	Min	Typ	Max	Unit
Clock	Frequency	1/Tc	138	143.9	150.5	MHz
Frame Period		Tv	1098	1120	1130	lines
			-	60	-	Hz
			-	16.7	-	ms
Vertical Display Period		Tvd	-	1080	-	lines
One line Scanning Period		Th	2080	2142	2220	clocks
Horizontal Display Period		Thd	-	1920	-	clocks

Note : The above is as optimized setting.



6.2 eDP Rx Interface Timing Parameter

The specification of the eDP Rx interface timing parameter is shown in Table 9.

<Table 9. eDP Main-Link RX TP4 Package Pin Parameters>

Item	Symbol	Min	Typ	Max	Unit	Remark
Spread spectrum clock (Link clock down-spreading)	ssc	0	-	0.5	%	
Differential peak-to-peak input voltage at package pins	VRX-DIFFp-p	120	-	1320	mV	
Rx input DC common mode voltage	VRX_DC_CM	0	-	2	V	
Differential termination resistance	RRX-DIFF	80	-	120	Ω	
Single-ended termination resistance	RRX-SE	40	-	60	Ω	
Rx short circuit current limit	IRX_SHORT	-	-	50	mA	
Intra-pair skew at Rx package pins (HBR) RX intra-pair skew tolerance at HBR	LRX_SKEW_ INTRA_PAIR	-	-	60	ps	

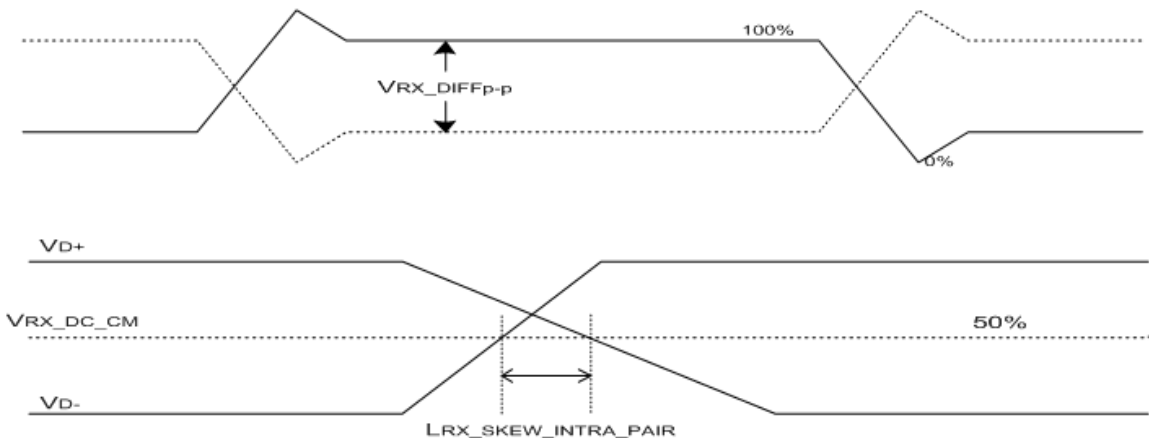

Figure 14. VRX-DIFFp-p & LRX_SKEW_INTRA_PAIR



7.0 INPUT SIGNALS, BASIC DISPLAY COLORS & GRAY SCALE OF COLORS

<Table 10. Input Signal & Basic Display Colors & Gray Scale of Colors >

	Colors & Gray scale	Data signal															
		R0 R1 R2 R3 R4 R5 R6 R7	G0 G1 G2 G3 G4 G5 G6 G7	B0 B1 B2 B3 B4 B5 B6 B7													
Basic colors	Black	0 0 0 0 0 0 0 0	0 0 0 0 0 0 0 0	0 0 0 0 0 0 0 0													
	Blue	0 0 0 0 0 0 0 0	0 0 0 0 0 0 0 0	1 1 1 1 1 1 1 1													
	Green	0 0 0 0 0 0 0 0	1 1 1 1 1 1 1 1	0 0 0 0 0 0 0 0													
	Light Blue	0 0 0 0 0 0 0 0	1 1 1 1 1 1 1 1	1 1 1 1 1 1 1 1													
	Red	1 1 1 1 1 1 1 1	0 0 0 0 0 0 0 0	0 0 0 0 0 0 0 0													
	Purple	1 1 1 1 1 1 1 1	0 0 0 0 0 0 0 0	1 1 1 1 1 1 1 1													
	Yellow	1 1 1 1 1 1 1 1	1 1 1 1 1 1 1 1	0 0 0 0 0 0 0 0													
	White	1 1 1 1 1 1 1 1	1 1 1 1 1 1 1 1	1 1 1 1 1 1 1 1													
Gray scale of Red	Black	0 0 0 0 0 0 0 0	0 0 0 0 0 0 0 0	0 0 0 0 0 0 0 0													
	△	1 0 0 0 0 0 0 0	0 0 0 0 0 0 0 0	0 0 0 0 0 0 0 0													
	Darker	0 1 0 0 0 0 0 0	0 0 0 0 0 0 0 0	0 0 0 0 0 0 0 0													
	△		↑														
	▽		↓														
	Brighter	1 0 1 1 1 1 1 1	0 0 0 0 0 0 0 0	0 0 0 0 0 0 0 0													
	▽	0 1 1 1 1 1 1 1	0 0 0 0 0 0 0 0	0 0 0 0 0 0 0 0													
	Red	1 1 1 1 1 1 1 1	0 0 0 0 0 0 0 0	0 0 0 0 0 0 0 0													
Gray scale of Green	Black	0 0 0 0 0 0 0 0	0 0 0 0 0 0 0 0	0 0 0 0 0 0 0 0													
	△	0 0 0 0 0 0 0 0	1 0 0 0 0 0 0 0	0 0 0 0 0 0 0 0													
	Darker	0 0 0 0 0 0 0 0	0 1 0 0 0 0 0 0	0 0 0 0 0 0 0 0													
	△		↑														
	▽		↓														
	Brighter	0 0 0 0 0 0 0 0	1 0 1 1 1 1 1 1	0 0 0 0 0 0 0 0													
	▽	0 0 0 0 0 0 0 0	0 1 1 1 1 1 1 1	0 0 0 0 0 0 0 0													
	Green	0 0 0 0 0 0 0 0	1 1 1 1 1 1 1 1	0 0 0 0 0 0 0 0													
Gray scale of Blue	Black	0 0 0 0 0 0 0 0	0 0 0 0 0 0 0 0	0 0 0 0 0 0 0 0													
	△	0 0 0 0 0 0 0 0	0 0 0 0 0 0 0 0	1 0 0 0 0 0 0 0													
	Darker	0 0 0 0 0 0 0 0	0 0 0 0 0 0 0 0	0 1 0 0 0 0 0 0													
	△		↑														
	▽		↓														
	Brighter	0 0 0 0 0 0 0 0	0 0 0 0 0 0 0 0	1 0 1 1 1 1 1 1													
	▽	0 0 0 0 0 0 0 0	0 0 0 0 0 0 0 0	0 1 1 1 1 1 1 1													
	Blue	0 0 0 0 0 0 0 0	0 0 0 0 0 0 0 0	1 1 1 1 1 1 1 1													
Gray scale of White& Black	Black	0 0 0 0 0 0 0 0	0 0 0 0 0 0 0 0	0 0 0 0 0 0 0 0													
	△	1 0 0 0 0 0 0 0	1 0 0 0 0 0 0 0	1 0 0 0 0 0 0 0													
	Darker	0 1 0 0 0 0 0 0	0 1 0 0 0 0 0 0	0 1 0 0 0 0 0 0													
	△		↑														
	▽		↓														
	Brighter	1 0 1 1 1 1 1 1	1 0 1 1 1 1 1 1	1 0 1 1 1 1 1 1													
	▽	0 1 1 1 1 1 1 1	0 1 1 1 1 1 1 1	0 1 1 1 1 1 1 1													
	White	1 1 1 1 1 1 1 1	1 1 1 1 1 1 1 1	1 1 1 1 1 1 1 1													



8.0 POWER SEQUENCE

To prevent a latch-up or DC operation of the LCD module, the power on/off sequence shall be as shown in below.

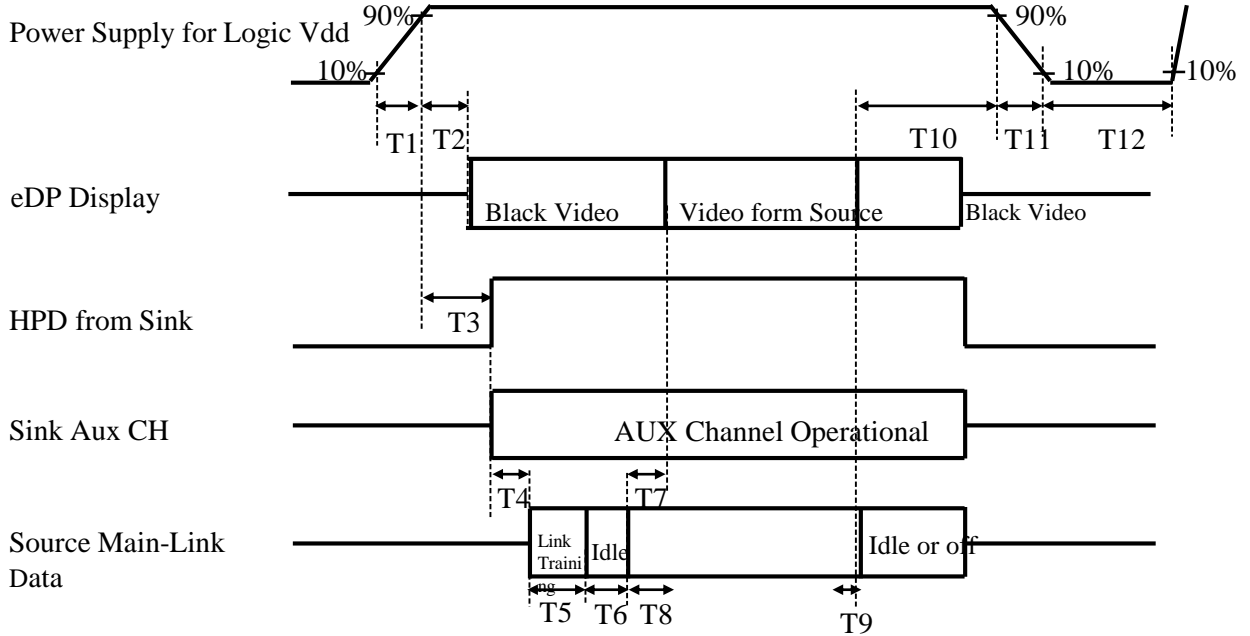

Figure 15. Power Sequence

- $0.5\text{ms} \leq T1 \leq 10\text{ms}$
- $0\text{ms} < T2 \leq 200\text{ms}$
- $0\text{ms} < T3 \leq 200\text{ms}$
- $T3+T4+T5+T6+T8 > 200\text{ms}$
- $0\text{ms} < T7 \leq 50\text{ms}$
- $50\text{ms} < T8$
- $0\text{ms} < T9$
- $0\text{ms} < T10 < 500\text{ms}$
- $0.5\text{ms} \leq T11 \leq 10\text{ms}$
- $500\text{ms} \leq T12$

Notes:

1. When the power supply VDD is 0V, keep the level of input signals on the low or keep high impedance.
2. Do not keep the interface signal high impedance when power is on. Back Light must be turn on after power for logic and interface signal are valid.



9.0 Connector Description

Physical interface is described as for the connector on LCM.

These connectors are capable of accommodating the following signals and will be following components.

9.1 TFT LCD Module

< Table 11. Signal Connector >

Connector Name /Description	For Signal Connector
Manufacturer	IPEX
Type/ Part Number	20455-030E-66
Mating housing/ Part Number	IPEX 20455-030E



10.0 MECHANICAL CHARACTERISTICS

10.1 Dimensional Requirements

Figure 20 shows mechanical outlines for the model HG173FH002-V0. Other parameters are shown in Table 12.

<Table 12. Dimensional Parameters>

Parameter	Specification	Unit
Active Area	381.89 (H) × 214.81 (V)	mm
Number of pixels	1920 (H) X 1080 (V) (1 pixel = R + G + B dots)	pixels
Pixel pitch	198.9 (H) × 198.9(V)	um
Pixel arrangement	RGB Vertical stripe	
Display colors	16.7 M(8bit)	
Display mode	Normally Black	
Dimensional outline	389.95(H) ±0.3 × 227.07(V)±3.0 (W PCB)	mm
Weight	500(max)	g

10.2 Mounting

See Figure 20.

10.3 Anti-Glare and Polarizer Hardness.

The surface of the LCD has an Anti-Glare coating to minimize reflection and a coating to reduce scratching.

10.4 Light Leakage

There shall not be visible light from the back-lighting system around the edges of the screen as seen from a distance 50cm from the screen with an overhead light level of 250lux.



11.0 RELIABILITY TEST

The reliability test items and its conditions are shown in below.

<Table 13. Reliability Test>

No	Test Items	Conditions
1	High temperature storage test	Ta = 70 °C, 240 hrs
2	Low temperature storage test	Ta = -30 °C, 240 hrs
3	High temperature/High humidity Storage	Ta = 70 °C, 80%RH, 240 hrs
4	High temperature operation test	Ta = 70 °C, 240 hrs
5	Low temperature operation test	Ta = -20°C, 240 hrs
6	Thermal Shock Storage	Ta = -20 °C ↔ 70 °C (0.5 hr), 100 cycle
7	Shock test (non-operating)	220G, 2ms, Half sine ±X, ±Y, ±Z once each direction
8	Package Vibration test	10-500hz , 1.5G, half sine, X, Y, Z/sweep 60min
9	Electro-static discharge test	Power OFF: Air discharged +/- 15kV Criteria C Contact discharged +/- 8kV Criteria C Power ON: Air discharged +/- 10kV Criteria B Contact discharged +/- 6kV Criteria B

12.0 HANDLING & CAUTIONS

(1) Cautions when taking out the module

- Pick the pouch only, when taking out module from a shipping package.

(2) Cautions for handling the module

- As the electrostatic discharges may break the LCD module, handle the LCD module with care. Peel a protection sheet off from the LCD panel surface as slowly as possible.
- As the LCD panel and back - light element are made from fragile glass material, impulse and pressure to the LCD module should be avoided.
- As the surface of the polarizer is very soft and easily scratched, use a soft dry cloth without chemicals for cleaning.
- Do not pull the interface connector in or out while the LCD module is operating.
- Put the module display side down on a flat horizontal plane.
- Handle connectors and cables with care.

(3) Cautions for the operation

- When the module is operating, do not lose CLK, ENAB signals. If any one of these signals is lost, the LCD panel would be damaged.
- Obey the supply voltage sequence. If wrong sequence is applied, the module would be damaged.



(4) Cautions for the atmosphere

- Dew drop atmosphere should be avoided.
- Do not store and/or operate the LCD module in a high temperature and/or humidity atmosphere. Storage in an electro-conductive polymer packing pouch and under relatively low temperature atmosphere is recommended.

(5) Cautions for the module characteristics

- Do not apply fixed pattern data signal to the LCD module at product aging.
- Applying fixed pattern for a long time may cause image sticking.

(6) Other cautions

- Do not disassemble and/or re-assemble LCD module.
- Do not re-adjust variable resistor or switch etc.
- When returning the module for repair or etc. Please pack the module not to be broken. We recommend to use the original shipping packages.

13.0 Packing Information

