



SPECIFICATION FOR TFT LCD MODULE

CUSTOMER : _____

CUSTOMER MODULE : _____

HG MODEL : HG140FH008

Preliminary Specification

Final Specification

Customer Confirmation column:

Approved by : _____ Dept. : _____ Data : _____

Please return one of the copies of the specification with your signature to us within two weeks after you receive this document. If it is not returned, we will assume that you agree to the entire contents of this specification document.

Designed by	Checked by	Approved by



Contents

No.	Items	Page
	CONTENTS	2
1.0	General Description	3
2.0	Absolute Maximum ratings	5
3.0	Electrical specifications.	6
4.0	Optical specifications.	9
5.0	Interface Connection	14
6.0	Signal Timing Specification	17
7.0	Input Signals, Display Colors & Gray Scale of Colors	19
8.0	Power Sequence	20
9.0	Connector description	21
10.0	Mechanical Characteristics	22
11.0	Reliability Test	24
12.0	Handling & Cautions.	25
13.0	Packing information	26
14.0	Mechanical Outline Dimension	27
15.0	EDID Table	29



1.0 GENERAL DESCRIPTION

1.1 Introduction

HG140FH008 is a color active matrix TFT LCD module using amorphous silicon TFT's (Thin Film Transistors) as an active switching devices. This module has a 14.0 inch diagonally measured active area with FHD resolutions (1920 horizontal by 1080 vertical pixel array). Each pixel is divided into RED, GREEN, BLUE dots which are arranged in vertical Stripe and this module can display 16.2M colors. The TFT-LCD panel used for this module is a low reflection and higher color type. Therefore, this module is suitable for Notebook PC. The LED Driver for back-light driving is built in this model. All input signals are eDP1.2 interface compatible.

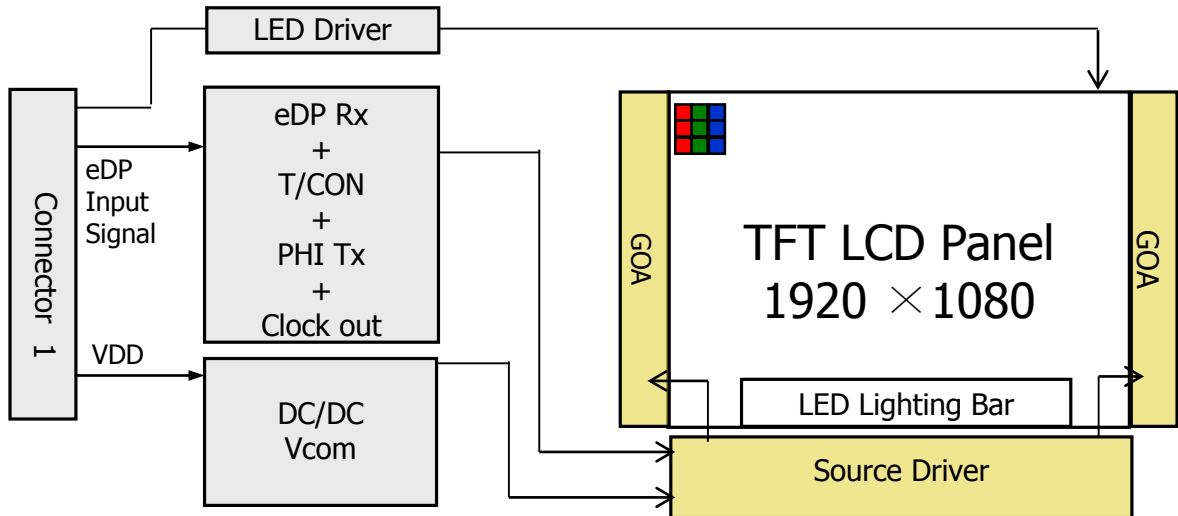

1.2 Features

- 2 lane eDP Interface with 2.7Gbps Link Rates
- Thin and light weight
- 6-bit color depth, display 16.2M colors
- Single LED Lighting Bar. (Down side/Horizontal Direction)
- Green Product (RoHS & Halogen free product)
- On board LED Driving circuit
- Low driving voltage and low power consumption
- On board EDID chip



1.0 General Description

1.3 Application

- Notebook PC Without Touch function

1.4 General Specification

1.4.1.General LCM Specification(Table 1.)

<Table 1. General Specifications>

Parameter	Specification	Unit	Remarks
Active area	309.3(H) x 173.99(V)	mm	
Number of pixels	1920 (H) x 1080 (V)	pixels	
Pixel pitch	0.1611 (H) x 0.1611 (V)	mm	
Pixel arrangement	RGB Vertical stripe		
Display colors	16.2M	colors	
Display mode	Normally Black		
Dimensional outline	315.9(H)*197.57(V) (W/PCB)*3.0(Max) 315.9(H)*186.05(V)(W/O PCB)*3.0(Max)	mm	
Weight	280(max)	g	
Back-light	Lower Down side, 1-LED Lighting Bar type		Note 1
Power consumption	P _D : 0.7	W	@mosaic pattern
	P _{BL} :2.55	W	
	P _{total} :3.25	W	

Notes : 1. LED Lighting Bar (36*LED Array)

2.0 ABSOLUTE MAXIMUM RATINGS

The followings are maximum values which, if exceed, may cause faulty operation or damage to the unit. The operational and non-operational maximum voltage and current values are listed in Table 2.

< Table 2. Absolute Maximum Ratings >

Ta=25+/-2°C

Parameter	Symbol	Min.	Max.	Unit	Remarks
Power Supply Voltage	V _{DD}	-0.5	4.0	V	Note 1
Logic Supply Voltage	V _{IN}	V _{SS} -0.3	V _{DD} +0.3	V	
Operating Temperature	T _{OP}	0	+50	°C	Note 2
Storage Temperature	T _{ST}	-20	+60	°C	

- Notes : 1. Permanent damage to the device may occur if maximum values are exceeded functional operation should be restricted to the condition described under normal operating conditions.
2. Temperature and relative humidity range are shown in the figure below.
 95 % RH Max. (40 °C ≥ Ta)
 Maximum wet - bulb temperature at 39 °C or less. (Ta > 40 °C) No condensation.

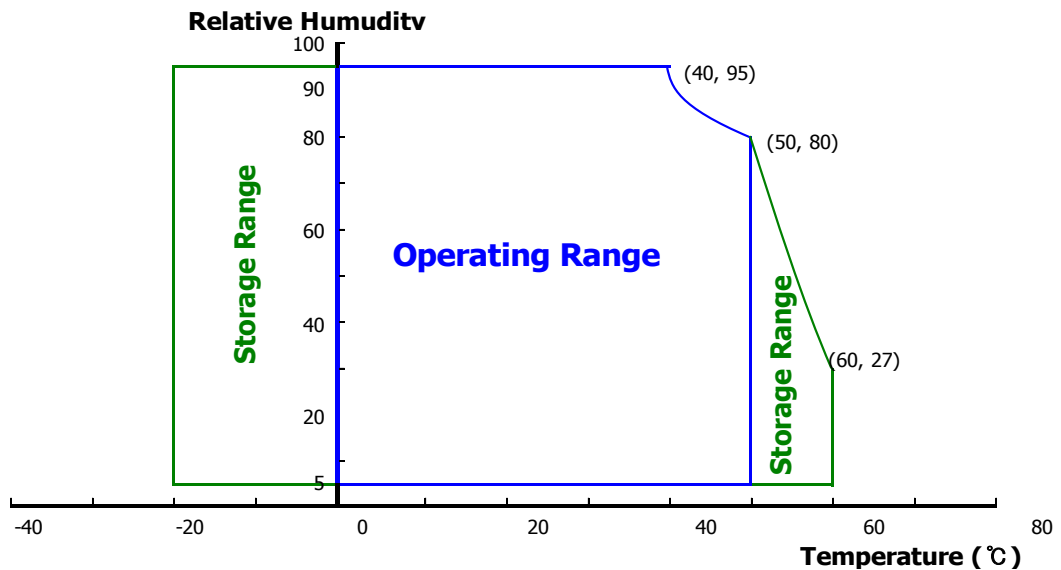



3.1 Electrical Specifications

< Table 3. Electrical Specifications >

Ta=25+/-2°C

Parameter		Min.	Typ.	Max.	Unit	Remarks
Power Supply Voltage	V _{DD}	3.0	3.3	3.6	V	Note 1
Permissible Input Ripple Voltage	V _{RF}	-	-	100	mV	At V _{DD} = 3.3V
Power Supply Current	I _{DD}	-	212	454	mA	Note 1
Power Supply Inrush Current	I _{inrush}	-	-	1.5	A	Note3
Power Consumption	P _D	-	0.7	1.5	W	Note 1
	P _{BL}	-	-	2.55	W	Note 2
	P _{total}	-	3.25	4.05	W	

Notes :

- The supply voltage is measured and specified at the interface connector of LCM.
The current draw and power consumption specified is for 3.3V at 25 °C.

a) Typ : Mosaic pattern



(a) Figure 3. Power Measure Patterns

- IF × VF × 36/ efficiency
- Measure condition

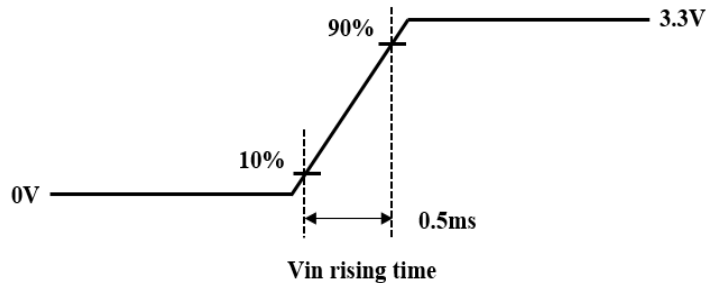



3.2 Backlight Unit

< Table 4. LED Driving guideline specifications >

Ta=25+/-2°C

Parameter		Min.	Typ.	Max.	Unit	Remarks
LED Forward Voltage	V _F	-	-	2.9	V	-
LED Forward Current	I _F	-	21	-	mA	-
LED Power Consumption	P _{LED}		2.55	-	W	Note 1
LED Life-Time	N/A	15,000	-	-	Hour	I _F = 21mA
LED Power Inrush Current	I _{rush}			1.5	A	Note 4
Power supply voltage for LED Driver	V _{LED}	5	12	21	V	
EN Control Level	Backlight on		2.0		5.0	V
	Backlight off		0		0.6	V
PWM Control Level	PWM High Level		2.0		5.0	V
	PWM Low Level		0		0.6	V
PWM Control Frequency	F _{PWM}	200	-	10,000	Hz	
Duty Ratio	-	1	-	100	%	Note 3

Notes :

1. Power supply voltage 12V for LED driver.

Calculator value for reference $I_F \times V_F \times 36 / \text{driver efficiency} = P_{LED}$

2. The LED life-time define as the estimated time to 50% degradation of initial luminous.

3. 1% duty cycle is achievable with a dimming frequency less than 2KHz.

4. Measure condition

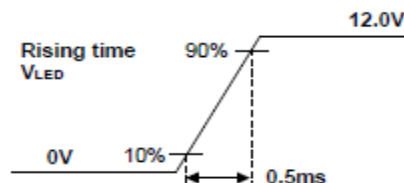



3.3 LED structure

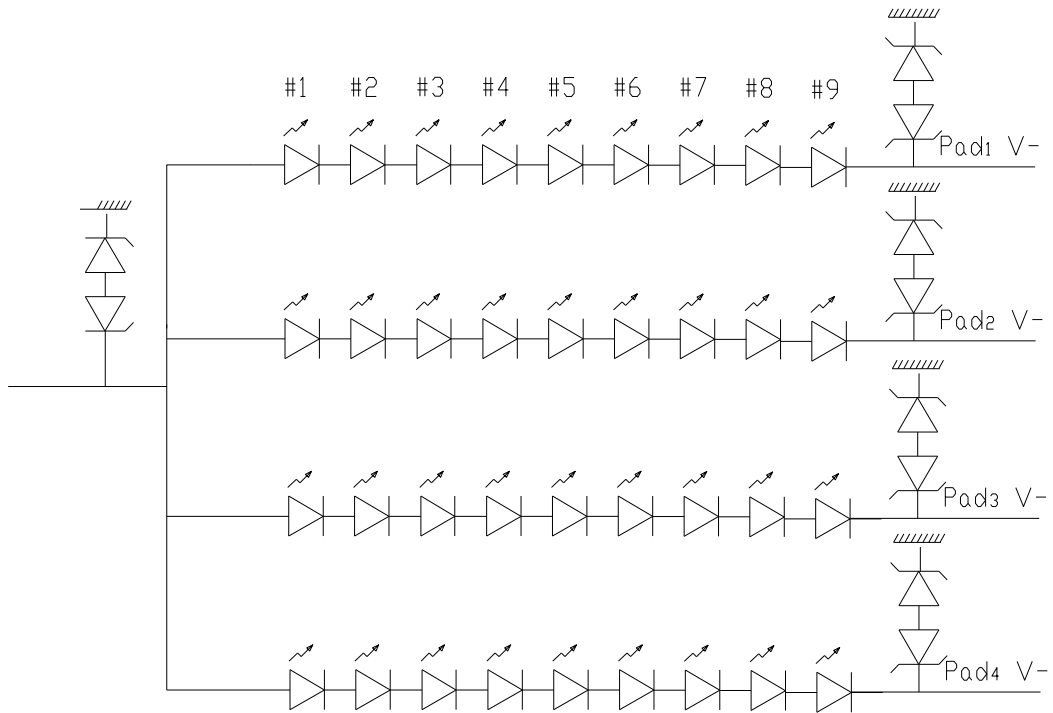



4.0 OPTICAL SPECIFICATION

4.1 Overview

The test of Optical specifications shall be measured in a dark room (ambient luminance ≤ 1 lux and temperature = $25 \pm 2^\circ\text{C}$) with the equipment of Luminance meter system (Goniometer system and PR730) and test unit shall be located at an approximate distance 50cm from the LCD surface at a viewing angle of θ and Φ equal to 0° . We refer to $\theta\emptyset=0$ ($=\theta_3$) as the 3 o'clock direction (the "right"), $\theta\emptyset=90$ ($=\theta_{12}$) as the 12 o'clock direction ("upward"), $\theta\emptyset=180$ ($=\theta_9$) as the 9 o'clock direction ("left") and $\theta\emptyset=270$ ($=\theta_6$) as the 6 o'clock direction ("bottom"). While scanning θ and/or \emptyset , the center of the measuring spot on the Display surface shall stay fixed. The backlight should be operating for 30 minutes prior to measurement. VDD shall be $3.3 \pm 0.3\text{V}$ at 25°C . Optimum viewing angle direction is 6 o'clock.

4.2 Optical Specifications

<Table 5. Optical Specifications>

Parameter		Symbol	Condition	Min.	Typ.	Max.	Unit	Remark
Viewing Angle range	Horizontal	Θ_3	CR > 10	-	85	-	Deg.	Note 1
		Θ_9		-	85	-	Deg.	
	Vertical	Θ_{12}		-	85	-	Deg.	
		Θ_6		-	85	-	Deg.	
Luminance Contrast ratio		CR	$\Theta = 0^\circ$	600	800	-	-	
Luminance of White	5 Points	Y_w	$\Theta = 0^\circ$ $I_{LED} = 21\text{mA}$	212.5	250	287.5	-	Type.
White Luminance uniformity	5 Points	ΔY_5		80%	-	-	-	Type.
	13 Points	ΔY_{13}		65%	-	-	-	
White Chromaticity		x_w	$\Theta = 0^\circ$	0.283	0.313	0.343	-	
		y_w		0.299	0.329	0.359	-	
Reproduction of color	Red	x_R	$\Theta = 0^\circ$	-0.03	0.585	+0.03	-	
		y_R			0.363		-	
	Green	x_G			0.350		-	
		y_G			0.578		-	
	Blue	x_B			0.163		-	
		y_B			0.138		-	
Gamut		-	-	-	45	-	%	
Response Time (Rising + Falling)		T_{RT}	$T_a = 25^\circ\text{C}$ $\Theta = 0^\circ$	-	30	35	Ms	Note 6
Cross Talk		CT	$\Theta = 0^\circ$	-	-	2	%	



Notes :

1. Viewing angle is the angle at which the contrast ratio is greater than 10. The viewing angles are determined for the horizontal or 3, 9 o'clock direction and the vertical or 6, 12 o'clock direction with respect to the optical axis which is normal to the LCD surface (see FIGURE 1).

2. Contrast measurements shall be made at viewing angle of $\Theta = 0$ and at the center of the LCD surface. Luminance shall be measured with all pixels in the view field set first to white, then to the dark (black) state .

(see FIGURE 1) Luminance Contrast Ratio (CR) is defined mathematically.

$$CR = \frac{\text{Luminance when displaying a white raster}}{\text{Luminance when displaying a black raster}}$$

3. Center Luminance of white is defined as luminance values of 5 point average across the LCD surface. Luminance shall be measured with all pixels in the view field set first to white. This measurement shall be taken at the locations shown in FIGURE 2 for a total of the measurements per display.

4. The White luminance uniformity on LCD surface is then expressed as : $\Delta Y = \text{Minimum Luminance of 5(or 13) points} / \text{Maximum Luminance of 5(or 13) points}$.

(see FIGURE 2 and FIGURE 3).

5. The color chromaticity coordinates specified in Table 5 shall be calculated from the spectral data measured with all pixels first in red, green, blue and white. Measurements shall be made at the center of the panel.

6. The electro-optical response time measurements shall be made as FIGURE 4 by switching the "data" input signal ON and OFF. The times needed for the luminance to change from 10% to 90% is T_r , and 90% to 10% is T_d .

7. Cross-Talk of one area of the LCD surface by another shall be measured by comparing the luminance (YA) of a 25mm diameter area, with all display pixels set to a gray level, to the luminance (YB) of that same area when any adjacent area is driven dark.

(See FIGURE 5).



4.3 Optical measurements

Figure 1. Measurement Set Up

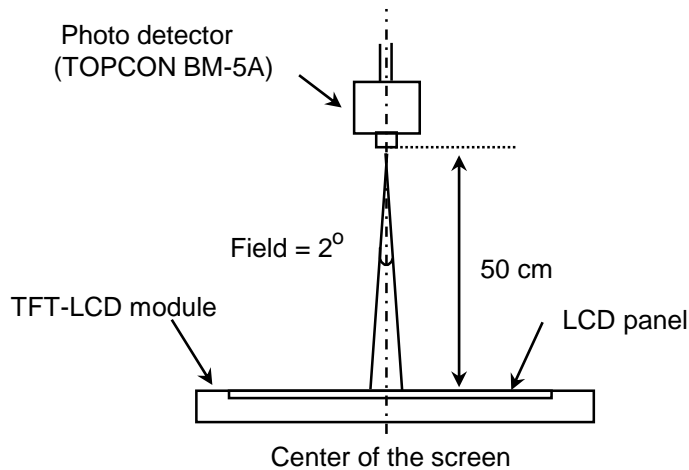

Optical characteristics measurement setup

Figure 2. White Luminance and Uniformity Measurement Locations (5 points)

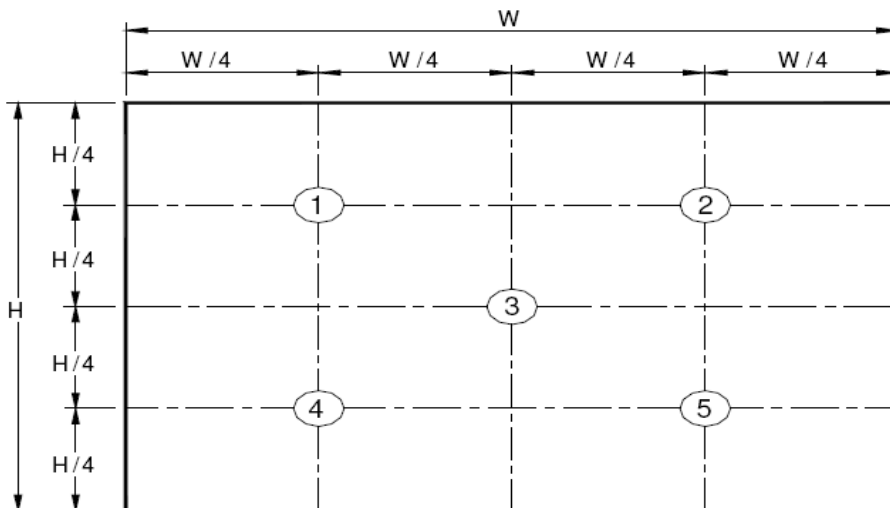

Center Luminance of white is defined as luminance values of center 5 points across the LCD surface. Luminance shall be measured with all pixels in the view field set first to white. This measurement shall be taken at the locations shown in FIGURE 2 for a total of the measurements per display.

Figure 3. Uniformity Measurement Locations (13 points)

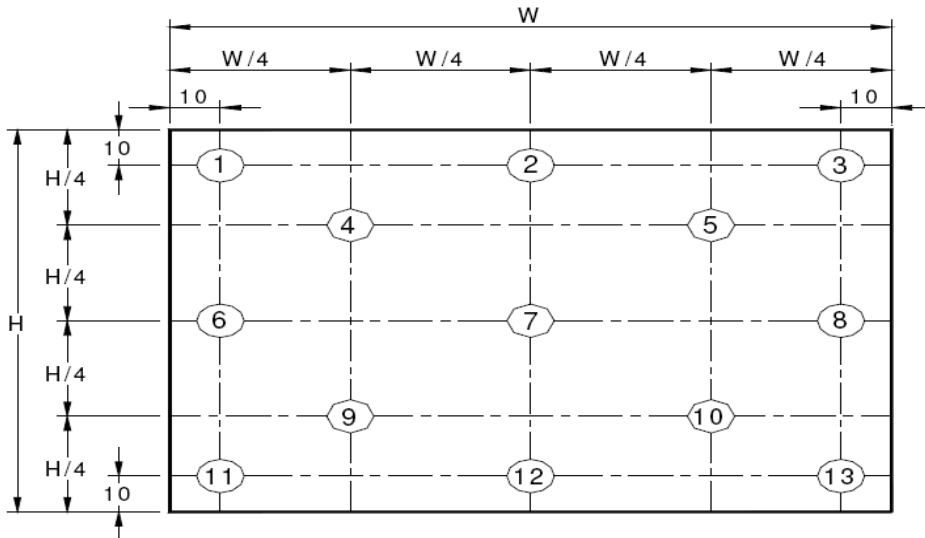

The White luminance uniformity on LCD surface is then expressed as : ΔY_5 = Minimum Luminance of five points / Maximum Luminance of five points (see FIGURE 2) , ΔY_{13} = Minimum Luminance of 13 points /Maximum Luminance of 13 points (see FIGURE 3).

Figure 4. Response Time Testing

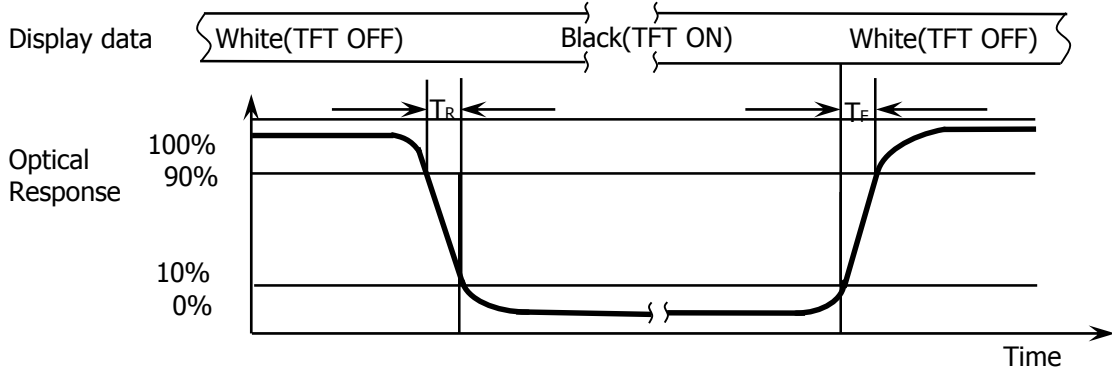

The electro-optical response time measurements shall be made as shown in FIGURE 4 by switching the “data” input signal ON and OFF. The times needed for the luminance to change from 10% to 90% is T_d and 90% to 10% is T_r .



Figure 5. Cross Modulation Test Description

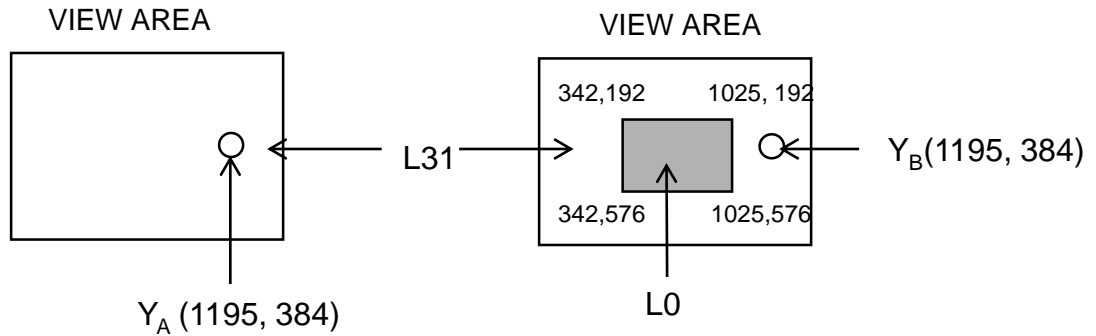

$$\text{Cross-Talk (\%)} = \left| \frac{Y_B - Y_A}{Y_A} \right| \times 100$$

Where:

Y_A = Initial luminance of measured area (cd/m²)

Y_B = Subsequent luminance of measured area (cd/m²)

The location measured will be exactly the same in both patterns

Cross-Talk of one area of the LCD surface by another shall be measured by comparing the luminance (Y_A) of a 25mm diameter area, with all display pixels set to a gray level, to the luminance (Y_B) of that same area when any adjacent area is driven dark (Refer to FIGURE 5).



5.0 INTERFACE CONNECTION.

5.1 Electrical Interface Connection

The electronics interface connector is MSAK24025P30 or Compatible.
The connector interface pin assignments are listed in Table 6.

<Table 6. Pin Assignments for the Interface Connector>

Terminal	Symbol	Functions
Pin No.	Symbol	Description
1	CABC_Enable	CABC
2	H-GND	Ground
3	LAN1_N	Complement Signal Link _Lane1
4	LAN1_P	True Signal Link _Lane1
5	H-GND	Ground
6	LAN0_N	Complement Signal Link _Lane0
7	LAN0_P	True Signal Link _Lane0
8	H-GND	High Speed Ground
9	AUXP	True Signal Link _Auxiliry Channel
10	AUXN	Complement Signal Link _Auxiliry Channel
11	H-GND	Ground
12	LCD_VCC	Power Supply, 3.3V (typ.)
13	LCD_VCC	Power Supply, 3.3V (typ.)
14	BIST	Panel self test enable
15	H-GND	Ground
16	H-GND	Ground
17	HPD	HPD(Hot Plug Detect) Signal Pin
18	BL_GND	High Speed Ground
19	BL_GND	High Speed Ground
20	BL_GND	High Speed Ground
21	BL_GND	High Speed Ground
22	BL_EN	Backlight on/off Control pin
23	BL_PWM	Back light PWM Dimming
24	Hsync	Line synchronization
25	NC	No connection
26	BL_PWR	Backlight power
27	BL_PWR	Backlight power
28	BL_PWR	Backlight power
29	BL_PWR	Backlight power
30	NC	No connection



5-2. eDP Interface

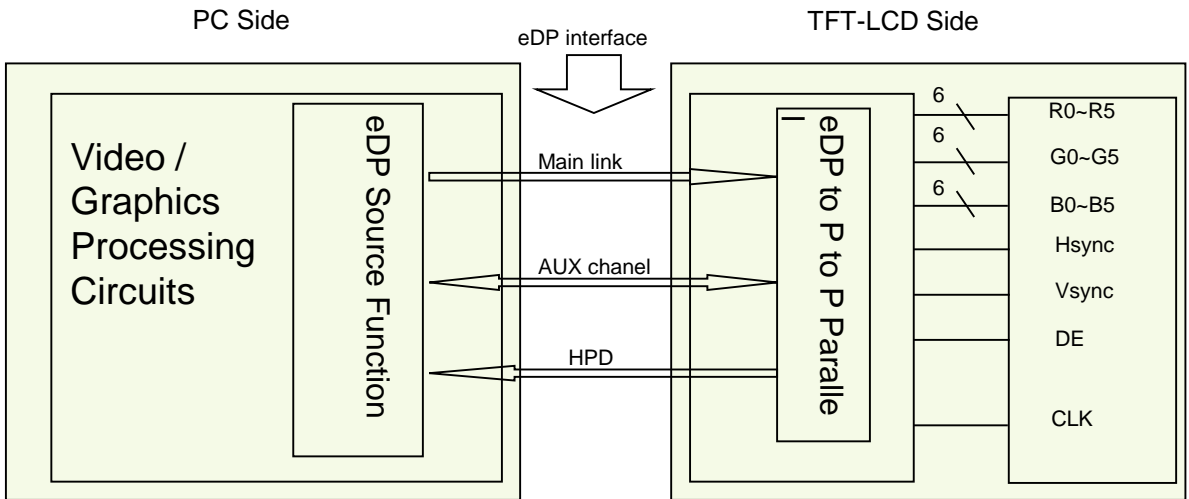

Note. Transmitter : DP501A or equivalent.
Transmitter is not contained in Module.



5.3 Back-light & LCM Interface Connection

<Table 7. Pin Assignments for the BLU & LCM Connector>

Pin No.	Symbol	Description	Pin No.	Symbol	Description
1	LED	LED cathode connection	6	GND	Ground
2	LED	LED cathode connection	7	NC	No Connection
3	LED	LED cathode connection	8	Vout	LED anode connection
4	LED	LED cathode connection	9	Vout	LED anode connection
5	NC	No Connection	10	Vout	LED anode connection



6.0 SIGNAL TIMING SPECIFICATION

6.1 The HG140FH008 is operated by the DE only.

Item		Symbols	Min	Typ	Max	Unit
Clock	Frequency	1/Tc	136.3	141.4	147.8	MHz
Frame Period		Tv	1092	1100	1120	lines
			-	60	-	Hz
			-	16.67	-	ms
Vertical Display Period		Tvd	-	1080	-	lines
One line Scanning Period		Th	2080	2142	2200	clocks
Horizontal Display Period		Thd	-	1920	-	clocks

Note 1 :The above is as optimized setting



6.2 eDP Rx Interface Timing Parameter

The specification of the eDP Rx interface timing parameter is shown in Table 8.

<Table 9. eDP Main-Link RX TP4 Package Pin Parameters>

Item	Symbol	Min	Typ	Max	Unit	Remark
Spread spectrum clock (Link clock down-spreading)	SSC	0	-	0.5	%	
Differential peak-to-peak input voltage at package pins	VRX-DIFFp-p	120	-	1200	mV	
Rx input DC common mode voltage	VRX_DC_CM	0	-	2.0	V	
Differential termination resistance	RRX-DIFF	80	-	120	Ω	
Single-ended termination resistance	RRX-SE	40	-	60	Ω	
Rx short circuit current limit	IRX_SHORT	0	-	50	mA	
Intra-pair skew at Rx package pins (HBR) RX intra-pair skew tolerance at HBR	LRX_SKEW_INTRA_PAIR	-	-	60	ps	

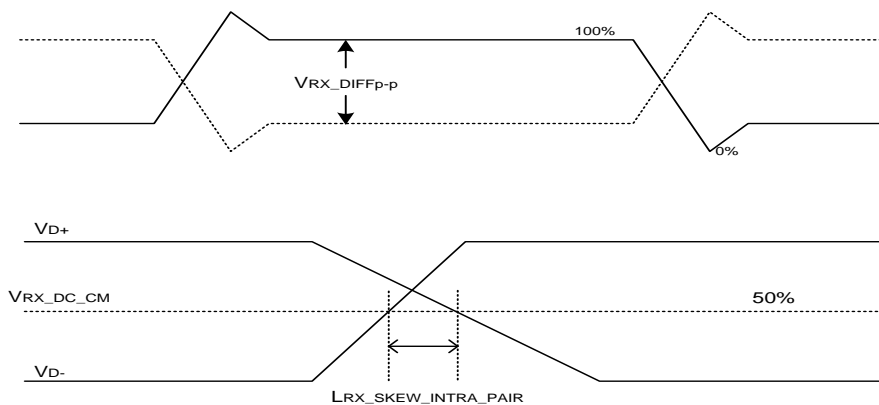



7.0 INPUT SIGNALS, BASIC DISPLAY COLORS & GRAY SCALE OF COLORS

	Colors & Gray scale	Data signal																							
		R0	R1	R2	R3	R4	R5	R6	R7	G0	G1	G2	G3	G4	G5	G6	G7	B0	B1	B2	B3	B4	B5	B6	B7
Basic colors	Black	0	0	0	0	0	0	0	0	0	0	0	0	0	0	0	0	0	0	0	0	0	0	0	0
	Blue	0	0	0	0	0	0	0	0	0	0	0	0	0	0	0	0	1	1	1	1	1	1	1	1
	Green	0	0	0	0	0	0	0	0	1	1	1	1	1	1	1	1	0	0	0	0	0	0	0	0
	Light Blue	0	0	0	0	0	0	0	0	1	1	1	1	1	1	1	1	1	1	1	1	1	1	1	1
	Red	1	1	1	1	1	1	1	1	0	0	0	0	0	0	0	0	0	0	0	0	0	0	0	0
	Purple	1	1	1	1	1	1	1	1	0	0	0	0	0	0	0	0	1	1	1	1	1	1	1	1
	Yellow	1	1	1	1	1	1	1	1	1	1	1	1	1	1	1	1	0	0	0	0	0	0	0	0
	White	1	1	1	1	1	1	1	1	1	1	1	1	1	1	1	1	1	1	1	1	1	1	1	1
Gray scale of Red	Black	0	0	0	0	0	0	0	0	0	0	0	0	0	0	0	0	0	0	0	0	0	0	0	0
	△	1	0	0	0	0	0	0	0	0	0	0	0	0	0	0	0	0	0	0	0	0	0	0	0
	Darker	0	1	0	0	0	0	0	0	0	0	0	0	0	0	0	0	0	0	0	0	0	0	0	0
	△																								
	▽																								
	Brighter	1	0	1	1	1	1	1	1	0	0	0	0	0	0	0	0	0	0	0	0	0	0	0	0
Gray scale of Green	Black	0	0	0	0	0	0	0	0	0	0	0	0	0	0	0	0	0	0	0	0	0	0	0	0
	△	0	0	0	0	0	0	0	0	1	0	0	0	0	0	0	0	0	0	0	0	0	0	0	0
	Darker	0	0	0	0	0	0	0	0	0	1	0	0	0	0	0	0	0	0	0	0	0	0	0	0
	△																								
	▽																								
	Brighter	0	0	0	0	0	0	0	0	1	0	1	1	1	1	1	1	0	0	0	0	0	0	0	0
Gray scale of Blue	Black	0	0	0	0	0	0	0	0	0	0	0	0	0	0	0	0	0	0	0	0	0	0	0	0
	△	0	0	0	0	0	0	0	0	0	0	0	0	0	0	0	0	1	0	0	0	0	0	0	0
	Darker	0	0	0	0	0	0	0	0	0	0	0	0	0	0	0	0	0	1	0	0	0	0	0	0
	△																								
	▽																								
	Brighter	0	0	0	0	0	0	0	0	0	0	0	0	0	0	0	0	1	0	1	1	1	1	1	1
Gray scale of White & Black	Black	0	0	0	0	0	0	0	0	0	0	0	0	0	0	0	0	0	0	0	0	0	0	0	0
	△	1	0	0	0	0	0	0	0	1	0	0	0	0	0	0	0	1	0	0	0	0	0	0	0
	Darker	0	1	0	0	0	0	0	0	0	1	0	0	0	0	0	0	0	1	0	0	0	0	0	0
	△																								
	▽																								
	Brighter	1	0	1	1	1	1	1	1	1	0	1	1	1	1	1	1	1	0	1	1	1	1	1	1
White	1	1	1	1	1	1	1	1	1	1	1	1	1	1	1	1	1	1	1	1	1	1	1	1	



8.0 POWER SEQUENCE

To prevent a latch-up or DC operation of the LCD module, the power on/off sequence shall be as shown in below

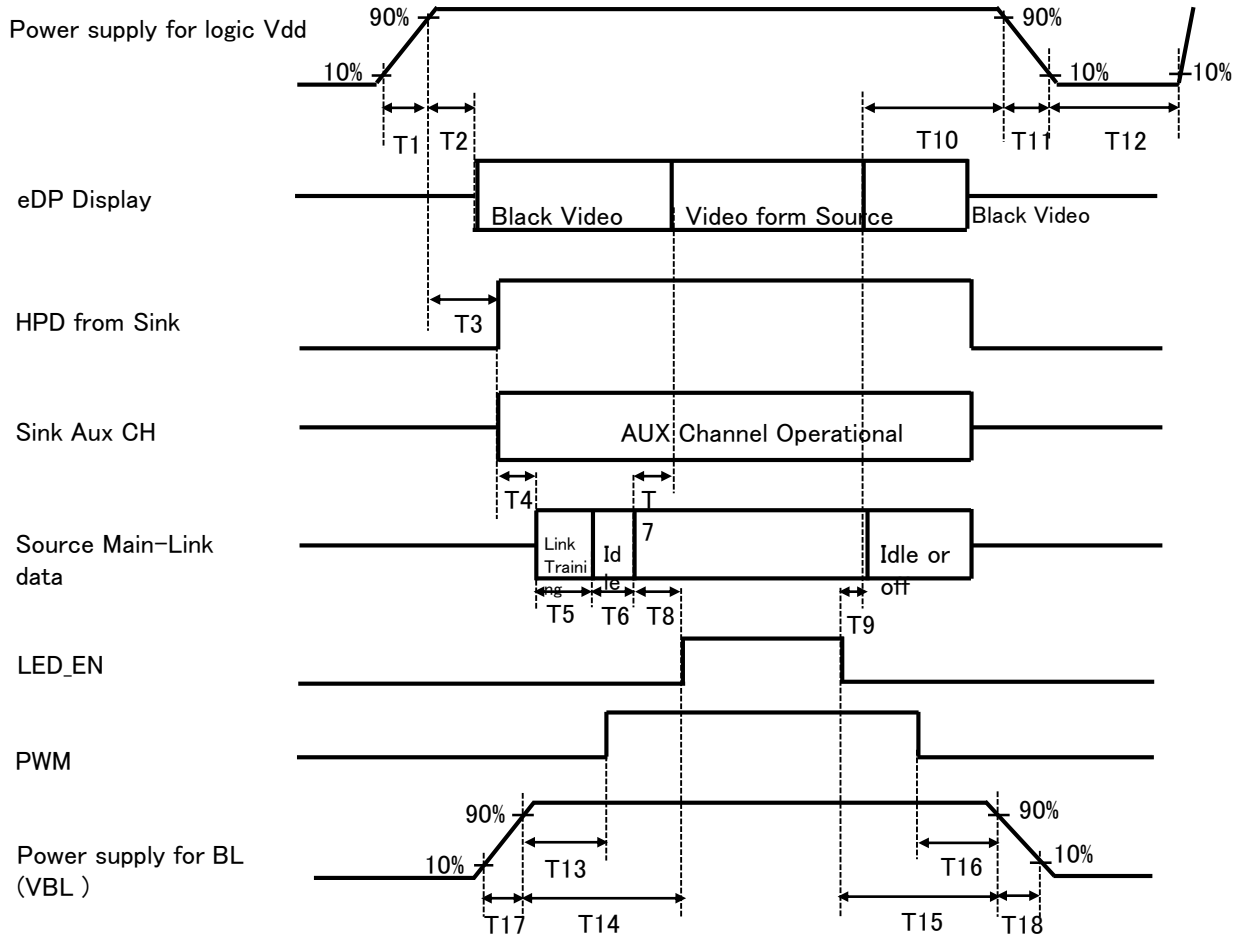

- $0.5\text{ms} \leq T1 \leq 10\text{ms}$
- $0\text{ms} < T2 \leq 200\text{ms}$
- $0\text{ms} < T3 \leq 200\text{ms}$
- $T3+T4+T5+T6+T8 > 200\text{ms}$
- $0\text{ms} < T7 \leq 50\text{ms}$
- $T7 < T8$
- $0\text{ms} < T9$
- $0\text{ms} < T10 < 500\text{ms}$
- $0.5\text{ms} \leq T11 \leq 10\text{ms}$
- $500\text{ms} \leq T12$
- $0\text{ms} < T13$
- $0\text{ms} < T14$
- $0\text{ms} < T15$
- $0\text{ms} < T16$
- $0.5\text{ms} \leq T17$
- $0.5\text{ms} \leq T18$

Notes:

1. When the power supply VDD is 0V, keep the level of input signals on the low or keep high impedance.
2. Do not keep the interface signal high impedance when power is on. Back Light must be turn on after power for logic and interface signal are valid.

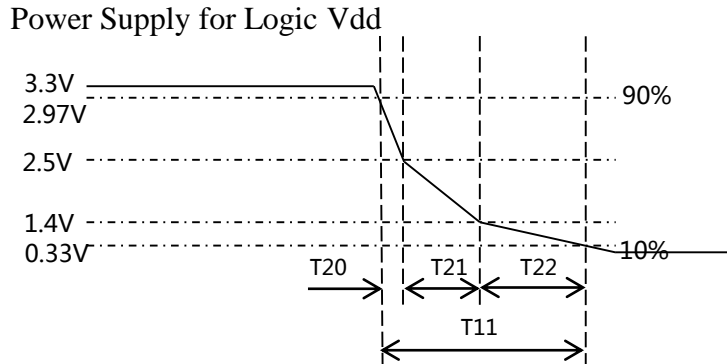

Figure 16. T11 timing requirements

- $0.5\text{ms} \leq T11 \leq 10\text{ms}$
- $0.225\text{ms} \leq T21$
- $T11 = T20 + T21 + T22$

9.0 Connector Description

Physical interface is described as for the connector on LCM.

These connectors are capable of accommodating the following signals and will be following components.

9.1 TFT LCD Module

Connector Name /Description	For Signal Connector
Manufacturer	STM or Compatible
Type/ Part Number	MSAK24025P30 or Compatible
Mating Housing/ Part Number	I-PEX 20454-030T or Compatible



10.0 MECHANICAL CHARACTERISTICS

10.1 Dimensional Requirements

FIGURE 6 shows mechanical outlines for the model HG140FH008. Other parameters are shown in Table 9.

<Table 9. Dimensional Parameters>

Parameter	Specification	Unit
Active Area	309.3 (H) x 173.99(V)	
Number of pixels	1920 (H) x 1080 (V)	
Pixel pitch	0.1611 (H) x 0.1611 (V)	mm
Pixel arrangement	RGB Vertical stripe	
Display colors	16.2M	
Display mode	Normally Black	
Dimensional outline	315.9(H)*197.57(V) (W/PCB)*3.0(Max) 315.9(H)*186.05(V)(W/O PCB)*3.0(Max)	mm
Weight	280(max)	gram
Back Light	Connector :MSAK24022P10 or Compatible	
	LED, Horizontal-LED Array type	

10.2 Mounting

See FIGURE 6.

10.3 Glare and Polarizer Hardness.

The surface of the LCD has a AG coating to minimize reflection and a coating to reduce scratching.

10.4 Light Leakage

There shall not be visible light from the back-lighting system around the edges of the screen as seen from a distance 50cm from the screen with an overhead light level of 300lux.



(4) Cautions for the atmosphere

- Dew drop atmosphere should be avoided.
- Do not store and/or operate the LCD module in a high temperature and/or humidity atmosphere. Storage in an electro-conductive polymer packing pouch and under relatively low temperature atmosphere is recommended.

(5) Cautions for the module characteristics

- Do not apply fixed pattern data signal to the LCD module at product aging.
- Applying fixed pattern for a long time may cause image sticking.

(6) Other cautions

- Do not disassemble and/or re-assemble LCD module.
- Do not re-adjust variable resistor or switch etc.
- When returning the module for repair or etc., Please pack the module not to be broken. We recommend to use the original shipping packages.



11.0 RELIABILITY TEST

The Reliability test items and its conditions are shown in below.

<Table 10. Reliability test>

No	Test Items	Conditions
1	High temperature storage test	Ta = 60°C , 60%RH, 240 hrs
2	Low temperature storage test	Ta = -20°C , 240 hrs
3	High temperature & high humidity operation test	Ta = 50°C , 80%RH, 240 hrs
4	High temperature operation test	Ta = 50°C , 60%RH, 240 hrs
5	Low temperature operation test	Ta = 0°C , 240 hrs
6	Thermal shock	Ta = -20 °C ↔ 60 °C (0.5 hr), 60% ± 3%RH, 100 cycle
7	Vibration test (non-operating)	Ta = 25°C , 60%RH, 1.5G, 10~500Hz, Sine X,Y,Z / Sweep rate : 1 hour
8	Shock test (non-operating)	Ta = 25°C , 60%RH, 220G, Half Sine Wave 2msec ± X, ± Y, ± Z Once for each direction
9	Electro-static discharge test (operating)	Air : 150 pF, 330Ω, 15 KV Contact : 150 pF, 330Ω, 8 KV Ta = 25°C , 60%RH,



12.0 HANDLING & CAUTIONS

- (1) Cautions when taking out the module
 - Pick the pouch only, when taking out module from a shipping package.
- (2) Cautions for handling the module
 - As the electrostatic discharges may break the LCD module, handle the LCD module with care. Peel a protection sheet off from the LCD panel surface as slowly as possible.
 - As the LCD panel and back - light element are made from fragile glass material, impulse and pressure to the LCD module should be avoided.
 - As the surface of the polarizer is very soft and easily scratched, use a soft dry cloth without chemicals for cleaning.
 - Do not pull the interface connector in or out while the LCD module is operating.
 - Put the module display side down on a flat horizontal plane.
 - Handle connectors and cables with care.
- (3) Cautions for the operation
 - When the module is operating, do not lose CLK, ENAB signals. If any one of these signals is lost, the LCD panel would be damaged.
 - Obey the supply voltage sequence. If wrong sequence is applied, the module would be damaged.
- (4) Cautions for the atmosphere
 - Dew drop atmosphere should be avoided.
 - Do not store and/or operate the LCD module in a high temperature and/or humidity atmosphere. Storage in an electro-conductive polymer packing pouch and under relatively low temperature atmosphere is recommended.
- (5) Cautions for the module characteristics
 - Do not apply fixed pattern data signal to the LCD module at product aging.
 - Applying fixed pattern for a long time may cause image sticking.
- (6) Other cautions
 - Do not disassemble and/or re-assemble LCD module.
 - Do not re-adjust variable resistor or switch etc.
 - When returning the module for repair or etc., Please pack the module not to be broken. We recommend to use the original shipping packages.

13.0 PACKING INFORMATION

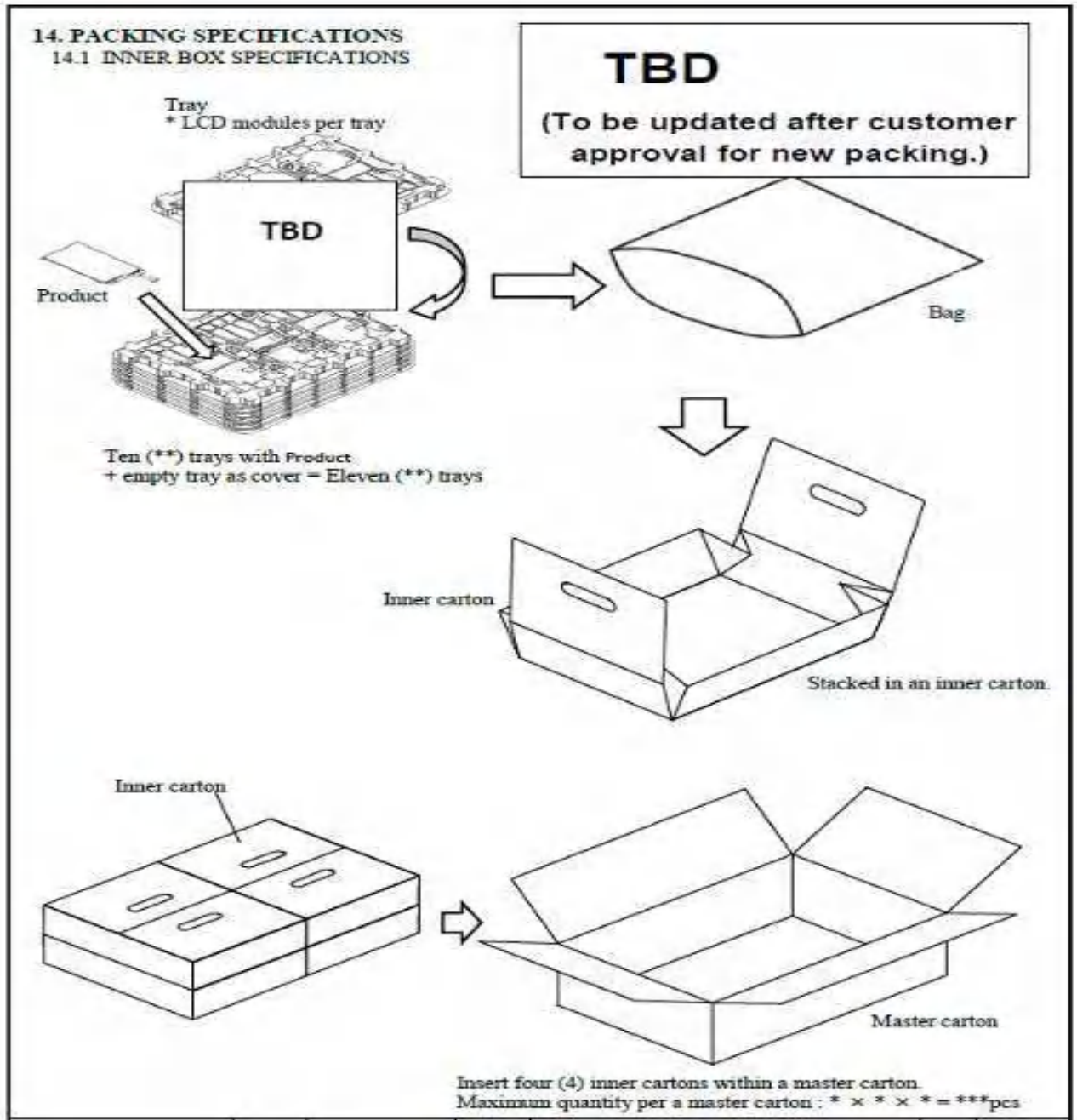



14.0 MECHANICAL OUTLINE DIMENSION

Figure 6. Outline Dimensions (Front view)

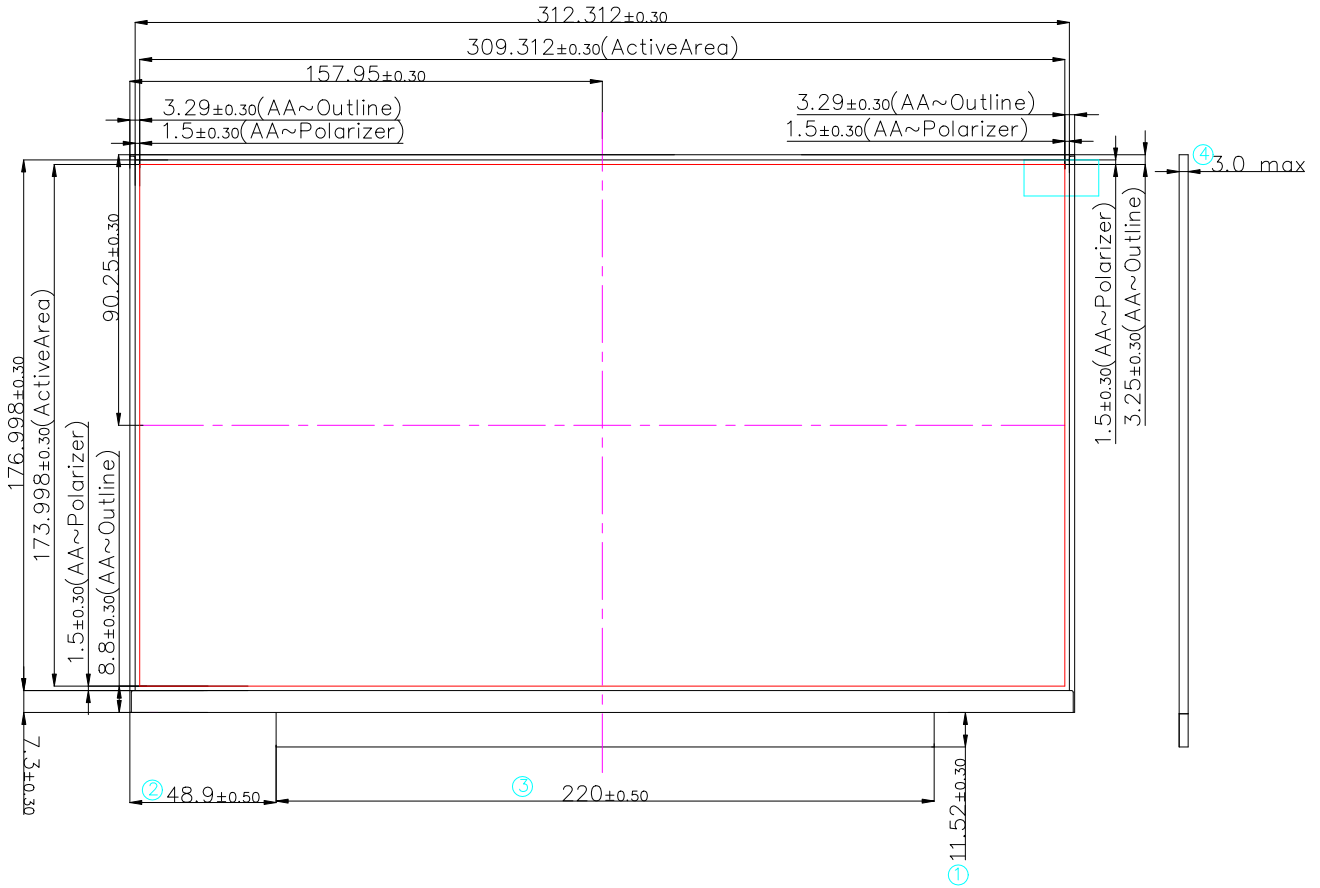

- Note:
1. Warps And Deformation spec $0 \leq d \leq 0.5\text{mm}$.
 2. EDP connector is measured at PIN 1 and MATING LINE.
 3. Unspecified tolerances refer to level "2".
 4. Top polarizer is the highest position of LCD, and any other componet is below the top polarizer.

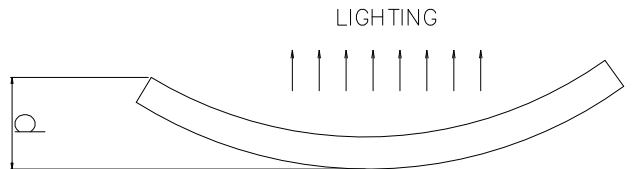



15.0 EDID Table

Address (HEX)	Function	Hex	Dec	crc	Input values.	Notes
00	Header	00	0		0	EDID Header
01		FF	255		255	
02		FF	255		255	
03		FF	255		255	
04		FF	255		255	
05		FF	255		255	
06		FF	255		255	
07		00	0		0	
08	ID Manufacturer Name	09	9			
09		E5	229			
0A	ID Product Code	F2	242		1778	ID = 1778
0B		06	6			
0C	32-bit serial No.	00	0			
0D		00	0			
0E		00	0			
0F		00	0			
10	Week of manufacture	20	32		32	
11	Year of Manufacture	1A	26		2016	Manufactured in 2016
12	EDID Structure Ver.	01	1		1	EDID Ver 1.0
13	EDID revision #	04	4		4	EDID Rev. 0.4
14	Video input definition	A5	165		-	digital signal/DP input
15	Max H image size	1F	31		31	31 cm (Approx)
16	Max V image size	11	17		17	17 cm (Approx)
17	Display Gamma	78	120		2.2	Gamma curve = 2.2
18	Feature support	02	2			RGB display, Preferred Timing mode/RGB 4:4:4
19	Red/Green low bits	FB	251		-	Red / Green Low Bits
1A	Blue/White low bits	90	144		-	Blue / White Low Bits
1B	Red x high bits	95	149	599	0.585	Red (x) = 10010101 (0.585)
1C	Red y high bits	5D	93	371	0.363	Red (y) = 01011101 (0.363)
1D	Green x high bits	59	89	358	0.350	Green (x) = 01011001 (0.35)
1E	Green y high bits	94	148	591	0.578	Green (y) = 10010100 (0.578)
1F	Blue x high bits	29	41	166	0.163	Blue (x) = 00101001 (0.163)
20	BLue y high bits	23	35	141	0.138	Blue (y) = 00100011 (0.138)
21	White x high bits	50	80	320	0.313	White (x) = 01010000 (0.313)
22	White y high bits	54	84	336	0.329	White (y) = 01010100 (0.329)
23	Established timing 1	00	0		-	
24	Established timing 2	00	0		-	
25	Established timing 3	00	0		-	
26	Standard timing #1	01	1			Not Used
27		01	1			
28	Standard timing #2	01	1			Not Used
29		01	1			
2A	Standard timing #3	01	1			Not Used
2B		01	1			
2C	Standard timing #4	01	1			Not Used
2D		01	1			
2E	Standard timing #5	01	1			Not Used
2F		01	1			
30	Standard timing #6	01	1			Not Used
31		01	1			
32	Standard timing #7	01	1			Not Used
33		01	1			
34	Standard timing #8	01	1			Not Used
35		01	1			



15.0 EDID Table

36	Detailed timing/monitor descriptor #1	3C	60		141.4	141.4MHz Main clock
37		37	55			
38		80	128		1920	Hor Active = 1920
39		DE	222		222	Hor Blanking = 222
3A		70	112		-	4 bits of Hor. Active + 4 bits of Hor. Blanking
3B		38	56		1080	Ver Active = 1080
3C		14	20		20	Ver Blanking = 20
3D		40	64		-	4 bits of Ver. Active + 4 bits of Ver. Blanking
3E		30	48		48	Hor Sync Offset = 48
3F		20	32		32	H Sync Pulse Width = 32
40		36	54		3	V sync Offset = 3 line
41		00	0		6	V Sync Pulse width : 6 line
42		35	53		309	Horizontal Image Size = 309 mm (Low 8 bits)
43		AD	173		173	Vertical Image Size = 173 mm (Low 8 bits)
44		10	16		-	4 bits of Hor Image Size + 4 bits of Ver Image Size
45		00	0		0	Hor Border (pixels)
46		00	0		0	Vertical Border (Lines)
47		1A	26			Refer to right table
48	Detailed timing/monitor descriptor #2	00	0		0.0	0MHz Main clock
49		00	0			
4A		00	0		0	Hor Active = 0
4B		00	0		0	Hor Blanking = 0
4C		00	0		-	4 bits of Hor. Active + 4 bits of Hor. Blanking
4D		00	0		0	Ver Active = 0
4E		00	0		0	Ver Blanking = 0
4F		00	0		-	4 bits of Ver. Active + 4 bits of Ver. Blanking
50		00	0		0	Hor Sync Offset = 0
51		00	0		0	H Sync Pulse Width = 0
52		00	0		0	V sync Offset = 0 line
53		00	0		0	V Sync Pulse width : 0 line
54		00	0		0	Horizontal Image Size = 0 mm (Low 8 bits)
55		00	0		0	Vertical Image Size = 0 mm (Low 8 bits)
56		00	0		-	4 bits of Hor Image Size + 4 bits of Ver Image Size
57		00	0		0	Hor Border (pixels)
58		00	0		0	Vertical Border (Lines)
59		1A	26			
5A	Detailed timing/monitor descriptor #3	00	0		ASCII Data Sting Tag	
5B		00	0			
5C		00	0			
5D		FE	254			
5E		00	0			
5F		42	66			
60		4F	79			
61		45	69			
62		20	32			
63		43	67			
64		51	81			
65		0A	10			
66		20	32			
67		20	32			
68		20	32			
69		20	32			
6A		20	32			
6B		20	32			



15.0 EDID Table

6C	Detailed timing/monitor descriptor #4	00	0			Product Name Tag (ASCII)
6D		00	0			
6E		00	0			
6F		FE	254			
70		00	0			
71		4E	78			
72		56	86			
73		31	49			
74		34	52			
75		30	48			
76		46	70			
77		48	72			
78		4D	77			
79		2D	45			
7A		4E	78			
7B		34	52			
7C	38	56				
7D	0A	10				
7E	Extension flag	00	0			
7F	Checksum	5A	90	90	-	